

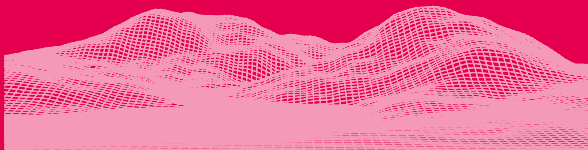

SONIC
MIGHTY

8K



Dear User,

Thank you for joining us. Please be sure to read the Sonic Mighty 8K manual thoroughly and carefully follow the step-by-step instructions to enjoy the best printing experience.

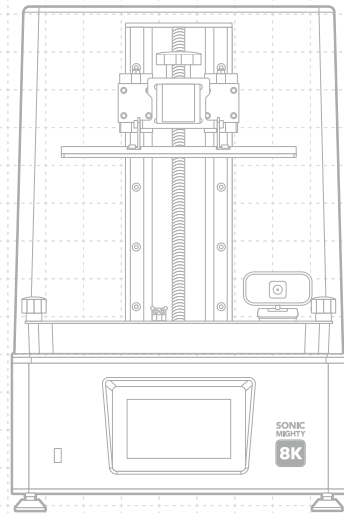



Please scan the QR code for
Sonic Mighty 8K user manual
in other languages.

03	01 Before You Start
04	02 Introduction
06	03 Prepare Your 3D Printer <ul style="list-style-type: none">· Guided Process for Initial Use· Z-Axis Calibration· Moving the Slider on the Z-Axis· Z-Offset Setting
08	04 Prepare Your CTB File
08	05 File Import & Network Connection
10	06 First Test Print
10	07 Remote Control App - Phrozen GO

01 Before You Start

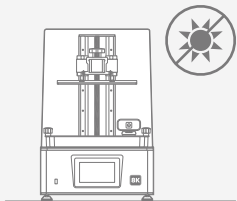

Stable Printing Environment

Store your 3D printer in a dry and ventilated environment. Avoid exposure to direct sunlight, and make sure to place the printer on a flat surface.

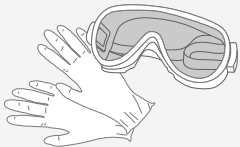

Protective Measures

While printing and using resin, please make sure to wear gloves, masks, protective goggles, and long-sleeved clothing.

Maintenance

Clean the Z-Axis

Wipe dry the z-axis screw, and apply a thin layer of general lubricant on the z-axis T-screw to make it rotate smoothly.

Clean the 3D Printer

Use 95% alcohol and tissue paper to carefully clean the printer, resin vat, and the building plate.

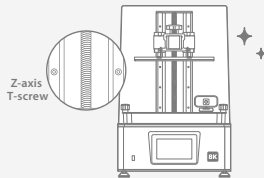

02 Introduction

Printer Parts

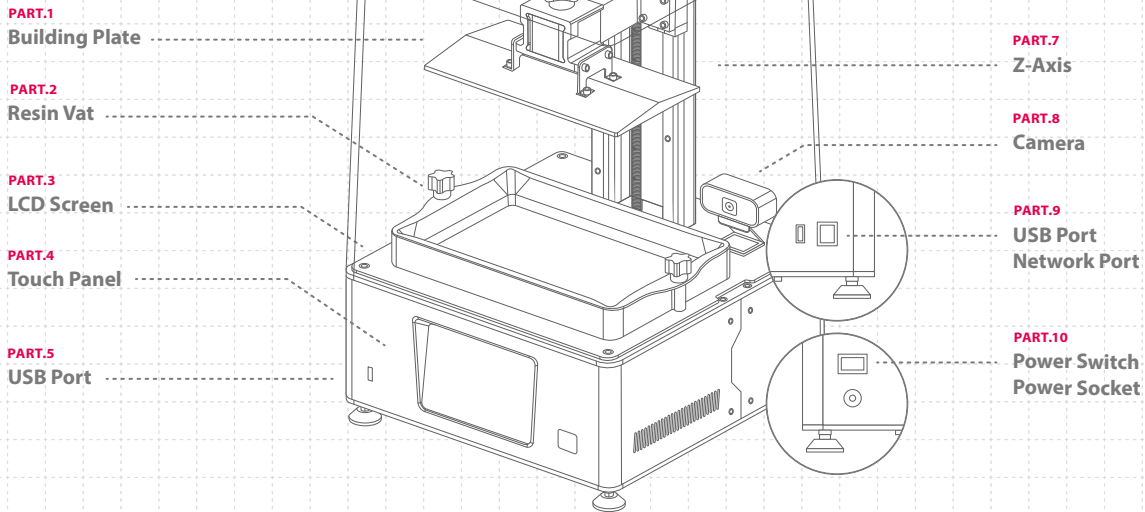

The Toolbox



After Sales Service Card



Gloves



Power Cord & Adapter



Plastic Funnel



Scrapers



Allen Wrench



USB



Wi-Fi Adapter

Operation

System	Phrozen OS
Operation	5 inch Touch Panel
Slicer Software	CHITUBOX V1.9.3 and above
Connectivity	Front USB Port Ethernet Wi-Fi
Storage	Built-in Memory

Printing Specifications

Technology	Resin 3D Printer - LCD Type
Light Source	Linear Projection LED Module
XY Resolution	28 μ m
Layer Thickness	0.01-0.30 mm
Max Printing Speed	70 mm / hr
Power Requirement	DC 24V ; 5A

Hardware Specifications

Printer Size	33.7 x 33.7 x 51.6 cm
Printing Volume	21.8 x 12.3 x 23.5 cm
Printer Weight	14.3 kg

* All specifications were tested in a laboratory and are subject to change without prior notice. For the latest update, please refer to Phrozen's official website.

* The included power cord set packaged with the main unit cannot be used with electrical equipment other than the specified device.

03 Prepare Your 3D Printer

Guided Process for Initial Use

When turning on your 3D printer for the first time, please follow the on-screen tutorial setup on the touch panel to complete the initial tests, including the LCD test, z-axis calibration, and first test print.

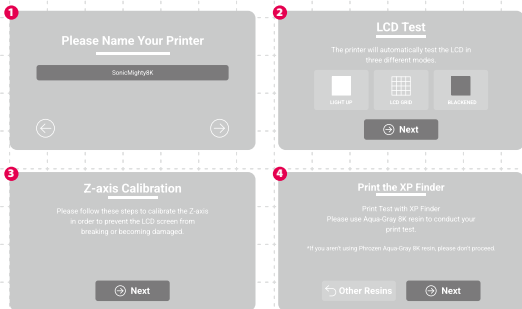

* If you miss the tutorial setup, please go to the "Settings" page on the left column of the touch panel and click "System Settings" > "Device Test" > "Factory Settings." The machine will restart and display the tutorial setup.

Z-Axis Calibration

Go to the "Tools" page on the left column of the touch panel and click "Z-Axis Control" > "Z-Axis Calibration."



Follow the on-screen instructions to perform z-axis calibration:

- 1 Remove the resin vat. Place a piece of A4 paper on top of the LCD screen.
- 2 Install the building plate and secure the thumb screw tightly. Then loosen the four calibration screws on both sides of the building plate.
- 3 Wait for the building plate to touch the LCD screen, then tighten the four calibration screws on both sides of the building plate.
- 4 Click "Finish" and wait for the building plate to return to its original position to complete the z-axis calibration.

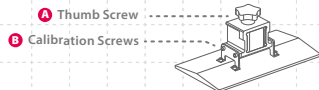

Moving the Slider on the Z-Axis.

To use this function, please pay attention to the procedure below each time you turn on the printer to let the z-axis detect the zero position:

- If you replace or readjust the building plate, z-axis, LCD screen, and screen protector, z-axis calibration needs to be performed each time afterward.
- If there is no need to replace or adjust the above parts, please click "Move to Z-Axis Zero Position".

* After completing the step, you'll be able to use the slider on the z-axis function.

Z-Offset Setting

Reposition your z-axis to print flat objects on the building plate. It is also helpful if the resin is viscous.

- 1 Complete the z-axis calibration first.
- 2 Click "Move to Z-Axis Zero Position."
- 3 It is recommended to raise the starting position by 0.1 mm.
- 4 Click "Reset Z-Offset" to complete the setting.

Reminder: Rebooting the firmware and performing z-axis calibration will reset the z-offset setting. Please repeat the z-offset setting before each printing.

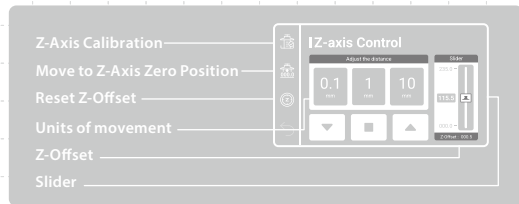

04 Prepare Your .CTB File

The Sonic Mighty 8K only supports .CTB format.
Use slicer software to turn STL and .OBJ files into .CTB files.

Convert .STL/ .OBJ File to .CTB File

- 1 Import .STL or .OBJ files into the slicer software. Choose "Sonic Mighty 8K" printer and set the resin parameters according to the resin used, and start slicing.
- 2 After the slicing is completed, save it as a .CTB file and your 3D model file is ready to be printed.

Test Files for Your First Print

- 1 The USB included in the tool box contains both .STL and .CTB files of two test models: "Phrozen_test" and "Phrozen_XP_Finder".
- 2 You can directly print the .CTB files in the USB with Aqua-Gray 8K Resin. If you are printing with other resins, slice the .STL files with the compatible parameter settings required for your resin.



Slicer Software



Resin Parameters



Learn & Download
Phrozen_XP_Finder

05 File Import & Network Connection

Sonic Mighty 8K can import files through a USB connection or via the Internet.

Import Files via USB

- 1 Save the .CTB file to your USB, and plug the USB into the printer.
- 2 On the "Print" menu in your touch panel, click "USB" > select the file you want to print > "Print".

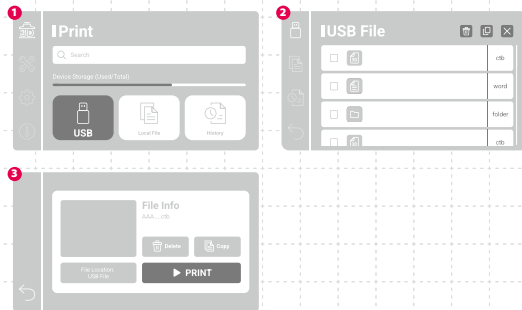

Import Files via Network Connection

1 Select the network connection method

Use the Wi-Fi adapter included in the tool box to connect to Wi-Fi, or plug in a network cable and connect through Ethernet.

2 Connecting to the internet

On the "Settings" page on the left column of the touch panel, click "Network" > "Wi-Fi" or "LAN Cable".



3 Locate the printer IP

Return to the "Settings" page and click "Sharing Network" > enable the setting. The "IP Address" is at the bottom-most field.

4 Connecting the printer to a computer

Have the computer connect to the same local area network as the printer, and enter the printer IP address into the empty folder location on your computer.

The username and password have to be entered manually for initial use.

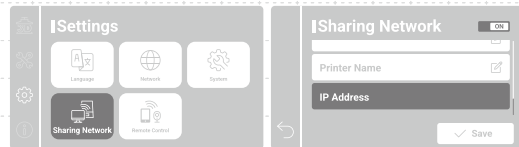

06 First Test Print

Use Aqua-Gray 8K Resin and the "Phrozen_XP_Finder".CTB file to perform the test.

- 1 Install the building plate and resin vat. Confirm that both are clean with no foreign objects.
- 2 Shake the resin evenly and pour it into the resin vat. Do not exceed the "MAX" mark on the resin vat when pouring.
- 3 Plug in the USB and select the "Phrozen_XP_Finder".CTB file to start printing.
- 4 Keep the plastic case closed during printing to prevent UV light leakage.
- 5 Once printing is completed, remove the building plate from the printer, place the building plate tilted onto a table and use the metal scraper to carefully remove your print.
- 6 Use a 95% alcohol or Phrozen Wash Resin Cleaner to rinse your printed model; then cure your models with a post-curing chamber; after curing, your first print is complete.



NOTICE: When installing the resin vat, please align the screws at the bottom of the resin vat with the platform grooves to avoid damage caused by the screws scratching the LCD panel.

07 Remote Control App - Phrozen GO

Phrozen GO is a mobile application designed for Phrozen printer users, so you can monitor your Phrozen 3D printers wherever you are. Please scan the QR Code to access the Phrozen GO tutorial.



Android



iOS

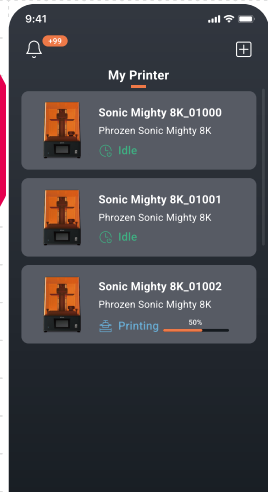

After-Sales Service & Warranty

- Phrozen offers a one-year warranty for all parts, excluding consumables components such as the LCD screen and PFA (nFEP) film.
- Sonic Mighty 8K LCD screen is covered under a 3-month warranty. Please note that this warranty does not cover any damages caused by human factors.
- If you encounter any difficulties, please scan the QR code to contact us.



Contact us!



Congratulations!

You have just completed your first run.
We hope you've had a great experience!

Please follow Phrozen's social media accounts
and subscribe to our YouTube channel to learn
more about printing tips and share information
with the community.



Facebook
Page



Facebook
User Group



YouTube



Instagram



SONIC
MIGHTY

8K

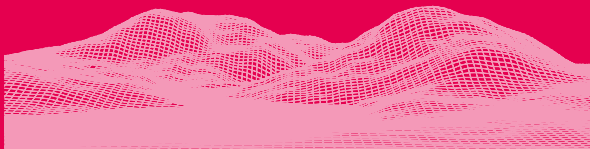

親愛的使用者您好，

非常開心您的加入，為了讓您擁有更良好的使用體驗，請務必詳閱 Sonic Mighty 8K 說明書並進行列印測試。

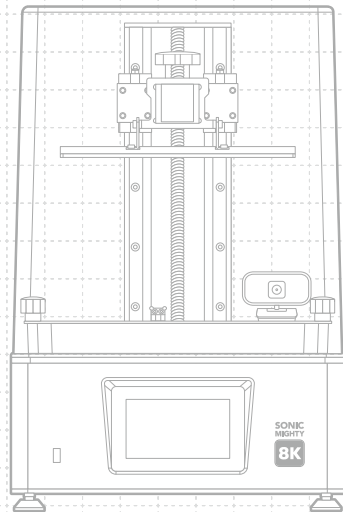



親愛的使用者您好

Sonic Mighty 8K 說明書支援
多種語言，請掃描 QR code 下載。

15	01 使用前注意事項
16	02 產品介紹
18	03 準備您的 3D 列印機 <ul style="list-style-type: none">· 初次使用引導流程· Z 軸校正· 移動 Z 軸位置滑軌· 重置 Z 軸起始點
20	04 準備 3D 列印檔案
20	05 檔案匯入與網路連線
22	06 進行列印測試
22	07 遠端控制 APP-Phrozen GO

01 使用前注意事項

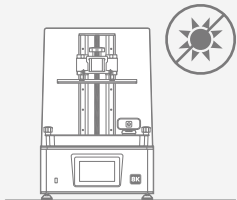

列印環境

請將 3D 列印機置於室內乾燥通風處之水平桌面，並避免陽光直射與高溫曝曬。

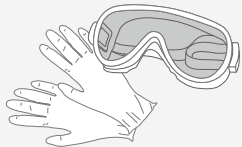

保護措施

進行列印時，請佩戴手套、口罩、護目鏡、長袖衣物等個人防護設備。

機台保養

Z 軸清潔

擦乾 Z 軸螺桿後，請使用少量一般潤滑油，潤滑 Z 軸螺桿使其運行更順暢。

機台清潔

可使用酒精 (建議 95% 酒精) 與紙巾小心擦拭機台、樹脂槽與列印載台。

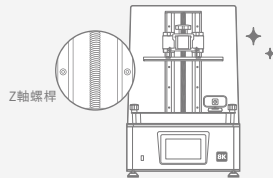

02 產品介紹

機台構造說明

PART.1

列印載台

PART.2

樹脂槽

PART.3

LCD 面板

PART.4

觸控螢幕

PART.5

USB 插孔

PART.6

壓克力遮光罩

PART.7

Z 軸

PART.8

攝影機

PART.9

USB 插孔
網路接孔

PART.10

電源開關
電源接孔

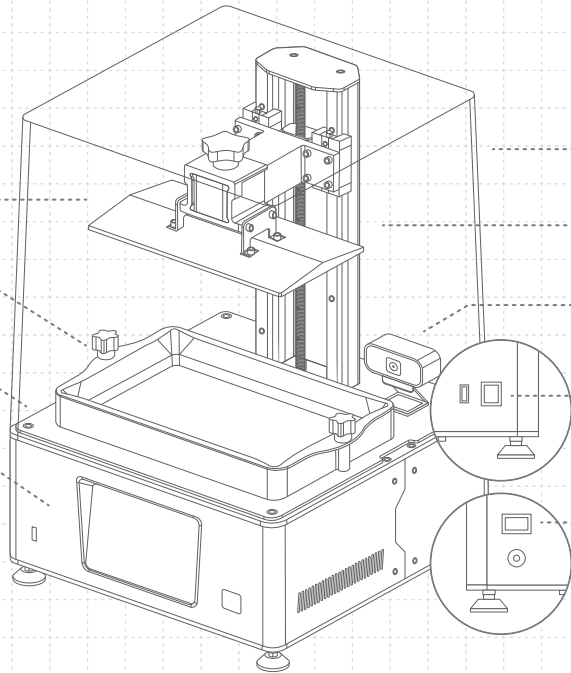

配件盒內容物



客服保固卡



手套



電源線/變壓器



塑膠漏斗



軟硬刮刀



六角板手



USB



USB 無線網卡

操作系統

機台系統	Phrozen OS 系統
操作介面	5 吋 OLED 觸控螢幕
切片軟體	CHITUBOX V1.9.3 以上
檔案傳輸模式	前置 USB 插孔 乙太網路 Wi-Fi
儲存方式	內置存儲

技術規格

技術規格	LCD 光固化
光源設計	Linear Projection LED Module
XY 解析度	28 μ m
切片厚度	0.01-0.30 mm
最快列印速度	70 毫米 / 小時
適用電壓	DC 24V ; 5A

硬體規格

機台尺寸	33.7 x 33.7 x 51.6 公分
列印尺寸	21.8 x 12.3 x 23.5 公分
機台重量	14.3 公斤

* 以上為實驗測試數據，若有內容更改請以官網為主。

* 機台附帶的電源線組只能與指定的電器設備一同使用，不得與其他電器設備搭配使用。

03 準備您的 3D 列印機

初次使用引導流程

初次開機請依照觸控螢幕的引導流程，完成基本設定、LCD 測試、Z 軸校正、列印測試。



* 若錯過引導流程，請點選觸控螢幕左側欄位「設定」頁面 > 「系統設定」 > 「設備測試」 > 「原廠設定」，機台將重新啟動，並再次進入引導流程。

Z 軸校正

觸控螢幕左側欄位「工具」頁面 > 「Z 軸控制」 > 左側欄位「Z 軸校正」。依照螢幕指示進行 Z 軸校正：



- 1 移除樹脂槽，並放置一張 A4 紙張在 LCD 面板上方。
- 2 安裝載台並鎖上手轉螺絲，接著鬆開載台兩側的四顆校正螺絲。
- 3 等待載台下降至底部接觸到 LCD 面板。
- 4 將載台兩側的四顆校正螺絲重新鎖緊。
- 5 點擊「完成」等待載台歸位後即完成 Z 軸校正。

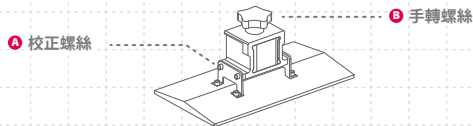

移動 Z 軸位置滑軌

使用此功能前，請在每次開機後，依照以下步驟，讓 Z 軸偵測到零點位置，完成後即可操作「移動 Z 軸位置滑軌」：

- 若有更換或調整載台、Z 軸、LCD 面板、LCD 保護貼，請進行「Z 軸校正」。
- 若無更換或調整上述構造，請點選「下降至 Z 軸零點」。

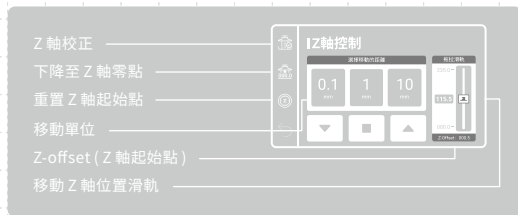

重置 Z 軸起始點

適用於使用黏稠樹脂列印，以及優化貼底列印。

- 1 請先完成 Z 軸校正。
- 2 點選「下降至 Z 軸零點」。
- 3 建議設定 0.1 mm 上升微調起始點位置。
- 4 確認位置後點擊「重置 Z 軸起始點」完成設定。

提醒：重刷韌體及 Z 軸校正都會刪除「Z-offset (Z 軸起始點)」紀錄，請務必於每次列印前再次確認「Z-offset (Z 軸起始點)」位置。

04 準備 3D 列印檔案

Sonic Mighty 8K 支援的 3D 列印檔案格式是「CTB 檔」。在開始列印前，您可以透過切片軟體將 3D 模型檔案（「STL 檔」或「OBJ 檔」）製作成 3D 列印檔案。

製作 3D 列印檔案

- 1 將 3D 模型檔案匯入切片軟體，新增「Sonic Mighty 8K」列印機，依照使用的樹脂設定樹脂參數，並開始切片。
- 2 切片完成後，儲存為 CTB 檔，3D 列印檔案即完成。

USB 中的測試檔案

- 1 配件盒中的 USB 存有「Phrozen_test」及「Phrozen_XP_Finder」兩個測試模型的 STL 檔與 CTB 檔，提供您進行測試。
- 2 您可以直接使用 USB 中的 CTB 檔，此 CTB 檔需搭配湖水灰 8K 樹脂列印。您也可以依照上述方法，將 STL 檔搭配欲使用的樹脂參數，經過切片後得到 3D 列印檔案。



切片軟體



樹脂參數



下載並了解更多
Phrozen_XP_Finder

05 檔案匯入與網路連線

Sonic Mighty 8K 可透過 USB 匯入檔案或是連接網際網路傳輸檔案。

透過 USB 匯入檔案

- 1 將 CTB 檔存入 USB，並將 USB 插入列印機。
- 2 在「列印」選單中依下列步驟操作觸控螢幕：點選「USB」> 選擇檔案 > 點選「列印」。

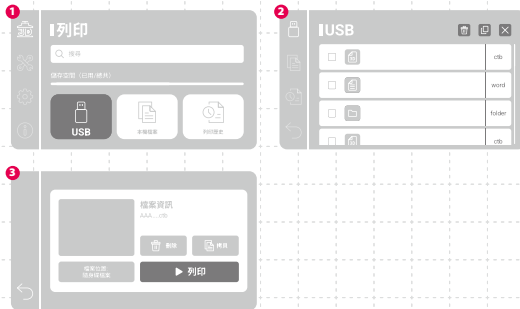

以網路連線傳輸檔案

1 選擇網路連線方式

使用配件盒中的 USB 無線網卡連線至 Wi-Fi 或插入網路線以乙太網路連線。

2 連線至網路

觸控螢幕左側欄位「設定」頁面 > 點擊「網路設置」 > 左側欄位「Wi-Fi」或「網路線」。



3 確認列印機 IP

回到「設定」頁面 > 點擊「共享設置」 > 「開啟」設定。最下方欄位的 IP 地址即為您的列印機 IP 碼。

4 將列印機連線至電腦

將列印機與電腦連線至同一區域網路，並將列印機 IP 碼輸入至電腦空白資料夾位置 (初次使用需手動輸入使用者名稱與密碼)。



06 進行列印測試

使用湖水灰 8K 樹脂與「Phrozen_XP_Finder」CTB 檔進行測試。

- 1 安裝樹脂槽與列印載台。確認兩者皆乾淨無異物。
- 2 將樹脂輕搖均勻後倒入樹脂槽，倒入時請勿超出樹脂槽上的「MAX」標記。
- 3 插入 USB 或在列印機內找到「Phrozen_XP_Finder」CTB 檔，選取此檔案開始列印。
- 4 列印時請蓋上壓克力遮光罩防止其它光線造成樹脂固化，影響列印。
- 5 列印完成後，將列印載台斜靠桌面，使用金屬刮刀將列印成品小心取下。
- 6 使用 95% 的酒精或 Phrozen Wash 等清洗劑清洗模型，再使用固化燈固化模型，列印測試即完成。

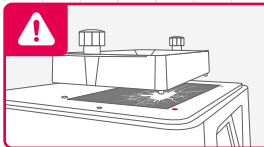

安裝樹脂槽時，請將樹脂槽底部螺絲對準平台凹槽放置，避免螺絲碰撞 LCD 面板造成損毀。

07 遠端控制 APP - Phrozen GO

Phrozen GO 是專為 Phrozen 機台使用者設計的 APP，讓您遠端操控一至數台 3D 列印機，掃描 QR Code 前往 Phrozen GO 教學。



Android



iOS

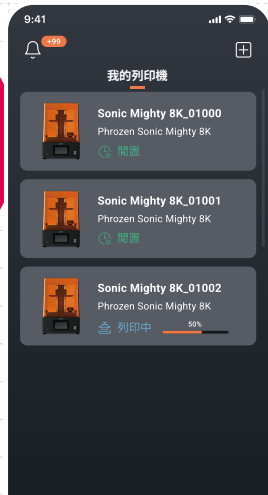

產品保固與售後服務

- 普羅森 3D 列印機台提供 1 年非人為損壞保固，列印耗材 LCD 面板與 PFA (nFEP) 離型膜除外。
- Sonic Mighty 8K 的 LCD 面板提供 3 個月非人為損壞保固。
- 若使用上遇到任何問題，請掃描右方 QRcode，聯絡普羅森團隊。



普羅森
客服團隊



恭喜

恭喜您完成初步操作流程，感謝您的支持並期望您有良好的使用體驗。

歡迎關注普羅森的社群帳號，並訂閱我們的 YouTube 頻道學習更多關於列印的技巧並分享您的列印經驗。



Facebook
粉絲專頁



Facebook
中文用戶社團



YouTube
中文站



Instagram