



Dahua 36-Port Managed Gigabit L3 Switch Quick Start Guide

V1.0.1

Foreword

General





This manual introduces the functions and operations of 36-port managed Gigabit L3 switch (hereinafter referred to as "the Device").

Model

DH-PFS5936-24GF8GT4XF

Safety Instructions

The following categorized signal words with defined meaning might appear in the Guide.

Signal Words	Meaning
 DANGER	Indicates a high potential hazard which, if not avoided, will result in death or serious injury.
 WARNING	Indicates a medium or low potential hazard which, if not avoided, could result in slight or moderate injury.
 CAUTION	Indicates a potential risk which, if not avoided, could result in property damage, data loss, lower performance, or unpredictable result.
 TIPS	Provides methods to help you solve a problem or save time.
 NOTE	Provides additional information as a supplement to the text.

Revision History

Version	Revision Content	Release Time
V1.0.1	Modified company address.	August 2023
V1.0.0	First release.	June 2019

Privacy Protection Notice

As the device user or data controller, you might collect personal data of others such as face, fingerprints, car plate number, Email address, phone number, GPS and so on. You need to be in compliance with the local privacy protection laws and regulations to protect the legitimate rights and interests of other people by implementing measures include but not limited to: providing clear and visible identification to inform data subject the existence of surveillance area and providing related contact.

About the Manual

- The manual is for reference only. If there is inconsistency between the manual and the actual product, the actual product shall prevail.
- We are not liable for any loss caused by the operations that do not comply with the manual.
- The manual would be updated according to the latest laws and regulations of related regions. For detailed information, see the paper manual, CD-ROM, QR code or our official website. If there is inconsistency between paper manual and the electronic version, the electronic version shall prevail.
- All the designs and software are subject to change without prior written notice. The product updates might cause some differences between the actual product and the manual. Please contact the customer service for the latest program and supplementary documentation.
- There still might be deviation in technical data, functions and operations description, or errors in print. If there is any doubt or dispute, please refer to our final explanation.
- Upgrade the reader software or try other mainstream reader software if the manual (in PDF format) cannot be opened.
- All trademarks, registered trademarks and the company names in the manual are the properties of their respective owners.
- Please visit our website, contact the supplier or customer service if there is any problem occurred when using the device.
- If there is any uncertainty or controversy, please refer to our final explanation.

Table of Contents

Foreword	I
1 Overview	1
1.1 Product Introduction	1
1.2 Front Panel.....	1
1.3 Rear Panel	1
1.4 Indicator Description	2
2 Installing the Device	3
2.1 Installing the Switch.....	3
2.1.1 Installing the Switch on the 19-inch Standard Rack	3
2.1.2 Installing the Switch on the Working Desk	4
2.2 Connecting the Cables.....	4
2.2.1 Connecting the Configuration Cable	4
2.2.2 Connecting the GND Cable.....	5
2.2.3 Connecting the Power Cable.....	5
2.2.4 Installing SFP Module and Connecting the Optical Fiber.....	6
3 Logging in the Device	7
3.1 VLAN Configuration	错误!未定义书签。
Appendix 1 Cybersecurity Recommendations	9

1 Overview

1.1 Product Introduction

The 36-Port Managed Gigabit L3 Switch has the following model:

Table 1-1 Model

Name	Model
36-Port Managed Gigabit L3 Switch with 24×100/1000Mbps SFP Ports, 8× Gigabit Ports and 4× 1G/10G SFP+	DH-PF55936-24GF8GT4XF

1.2 Front Panel

See Figure 1-1 for the front panel of the switch.

Figure 1-1 Front panel

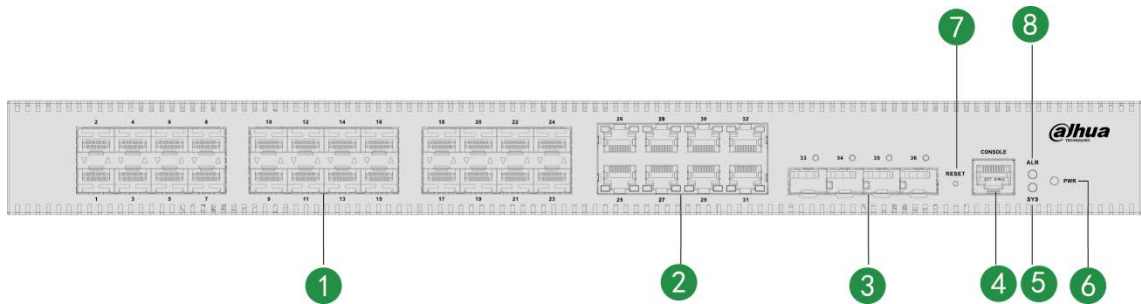

Table 1-2 Front panel description

No.	Description
1	100/1000 M Base-X SFP
2	10/100/1000 M Base-T RJ-45 port
3	1/10 G Base-X SFP+
4	Console port
5	SYS
6	PWR (power indicator)
7	RESET
8	ALR

1.3 Rear Panel

See Figure 1-2 for the rear panel of the switch.

Figure 1-2 Rear panel

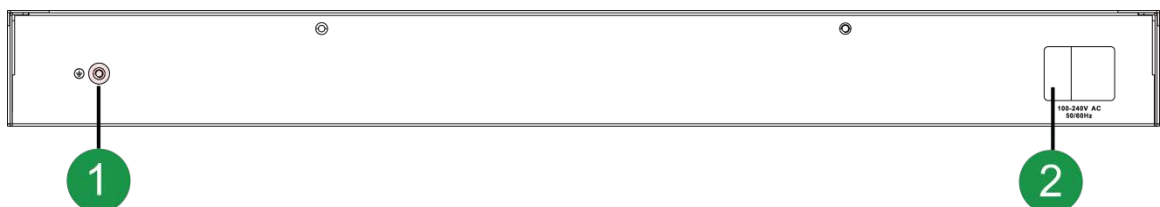

Table 1-3 Rear panel description

No.	Description
1	GND screw
2	AC power port

1.4 Indicator Description

Table 1-4 Indicator description

Indicator	Status	Description
PWR	ON (green light)	The switch is powered on and the power module is working properly.
	OFF	The switch is not powered on or the power module is not working properly.
SYS	Flashing (green light)	The system is working properly.
	OFF	The system is not working properly.
ALR	ON (red light)	There is abnormal alarm.
	OFF	There is no abnormal alarm.
RJ-45 port Link/Act	ON (green light)	The RJ-45 port is working at the rate of 10/100/1000 Mbps and the port is connected to the opposite device properly.
	Flashing (yellow light)	The RJ-45 port is working at the rate of 10/100/1000 Mbps and the port is sending and receiving data.
	OFF	The RJ-45 port is not connected to the opposite device or connection failed.
SFP port module	ON (green light)	The SFP port is working at the rate of 1/10 Gbps and the port is connected to the opposite device properly.
	Flashing (green light)	The SFP port is working at the rate of 1/10 Gbps and the port is sending and receiving data.
	OFF	The SFP port is not connected to the opposite device or connection failed.

2 Installing the Device

The switch can be installed on the 19-inch standard rack, and it can also be directly placed on the working desk.

To avoid damage to the device or human, follow the attentions:

- Do not place the switch near water and keep away from humid environment to avoid water and moisture getting into the device.
- Make sure the working environment of switch is clean, because the dust might cause electrostatic adsorption, which not only affects the switch working life, but also causes communication failure easily.
- Make sure the air vent is not blocked, and do not pile up the switch.
- Make sure the switch is working at the proper and stable voltage.
- Make sure the grounding is normal with the grounding terminal at the rear panel of the switch before using the switch.
- Unplug the power before cleaning the switch. Do not wipe the switch with wet cloth, and do not clean the switch with liquid.
- Do not disassemble the switch enclosure when the switch is working, and do not optionally disassemble the switch enclosure even if the switch is not powered on.



The switch is the class A product, and it might cause radio disturbance in the environment. You could take practical measures to avoid radio disturbance.

2.1 Installing the Switch

2.1.1 Installing the Switch on the 19-inch Standard Rack

To install the switch on the 19-inch standard rack, do the following:

Step 1 Check the grounding of the rack, and make sure the rack is stable.

Step 2 Fix the rackmount hangers on both sides of the switch front panel with the screws.

Figure 2-1 Tightening the rackmount hangers

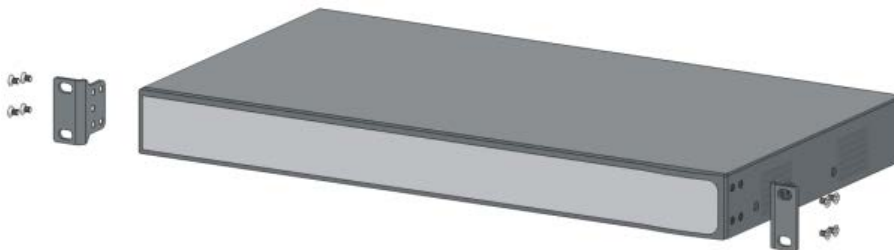

Step 3 Place the switch on the carrier on the rack, and push the switch along the guide slot to a proper position.

Step 4 Fix the rackmount hangers on the guide slot of the rack with the screws to make sure the switch is secured.

Figure 2-2 Installing the switch

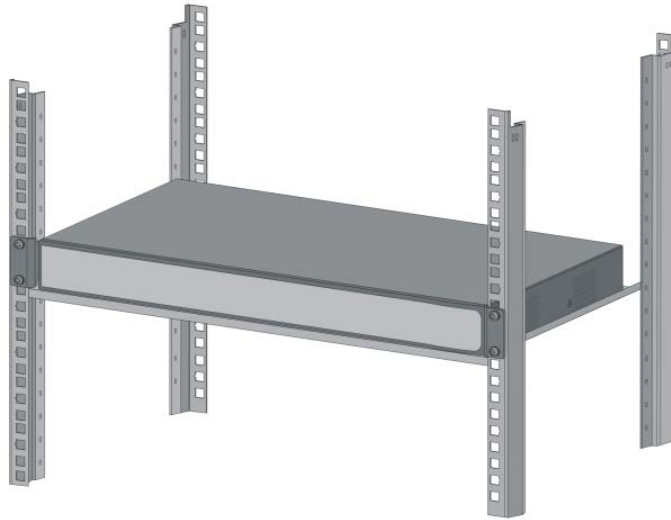

The rackmount hangers are not for sustaining the weight of the switch, and they are for fixing the switch. The carrier is necessary for sustaining the switch.

2.1.2 Installing the Switch on the Working Desk

You can place the switch on the clean, stable, and grounded working desk.

To install the switch on the working desk, do the following:

- Step 1** Place the switch upside down carefully, and clean the groove on the switch baseboard with the soft cloth. Make sure there is no oil or dust.
- Step 2** Tear off the sticker on the surface of the supplied foot pad, and paste the foot pad on the groove on the switch baseboard.
- Step 3** Turn the switch over, and place the switch on the working desk right side up.

2.2 Connecting the Cables

2.2.1 Connecting the Configuration Cable

Figure 2-3 Connecting the configuration cable



To connect the configuration cable, do the following:

Step 1 Connect the DB-9 plug of the configuration cable to the serial port of the PC.

Step 2 Connect the RJ-45 port of the configuration cable to the Console port of the switch.

2.2.2 Connecting the GND Cable



The GND cable is not supplied, and you need to purchase it by yourself.

Connecting the GND cable well is the important safeguard for lightning protection and anti-electromagnetic interference.

To connect the GND cable, do the following:

Step 1 Remove the GND screw on the switch GND point with the cross screwdriver, and thread the GND screw through the hole on the OT terminal of the GND cable. Rotate the GND screw clockwise with the cross screwdriver, and fix the OT terminal of the GND cable with the switch GND point.

Step 2 Wind the other side of the GND cable into the circle with the nipper pliers.

Step 3 Connect the other side of the GND cable with the grounding bar, and rotate the hex nut clockwise with the wrench to fix the other side of the GND cable on the grounding pole.

Figure 2-4 Connecting the GND cable

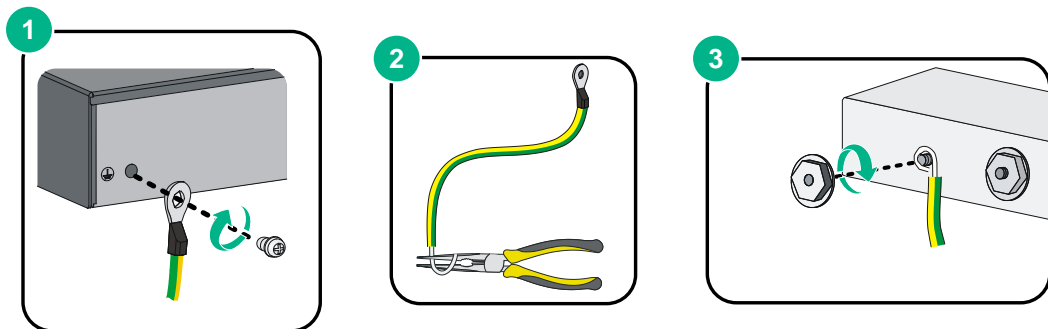

2.2.3 Connecting the Power Cable

Make sure the switch is well grounded before you connect the power cable.

To connect the power cable, do the following:

Step 1 Insert one side of the supplied power cable into the AC power supply hub of the switch.

Step 2 Connect the other side of the power cable to the external AC power socket.

Figure 2-5 Connecting the power cable

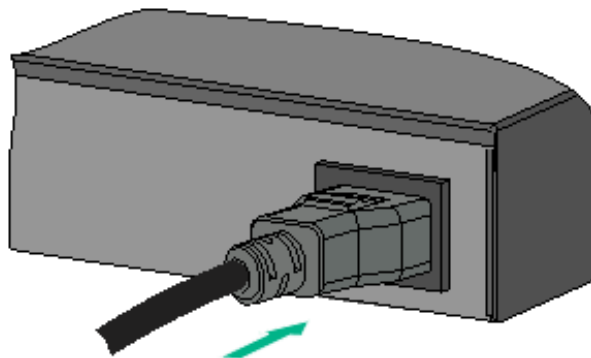

2.2.4 Installing SFP Module and Connecting the Optical Fiber



WARNING

- Do not touch the golden finger of the SFP module when installing the SFP module.
- Do not pull out the dustproof plug of the SFP module before connecting the optical fiber.
- Do not directly insert the SFP module connected with the optical fiber into the SFP slot. Pull out the optical fiber first before inserting the SFP module.

To install the SFP module and connect the optical fiber, do the following:

Step 1 Wear the antistatic wrist, and make sure the antistatic wrist and your skin are in good contact and well grounded.

Step 2 Lift the handle of SFP module upward vertically. Hold the SFP module by both sides, and push it gently into the SFP slot till the SFP module is firmly connected to the slot

Figure 2-6 Installing the SFP module

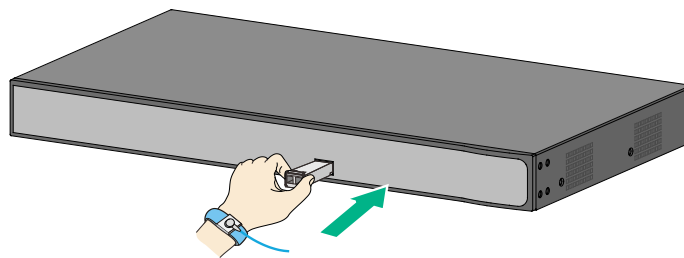

Step 3 Remove the dust cap on the LC connector of the optical fiber and the dustproof plug of the SFP module.

Step 4 Connect the LC connector of the optical fiber with the SFP module.

Figure 2-7 Connecting the optical fiber

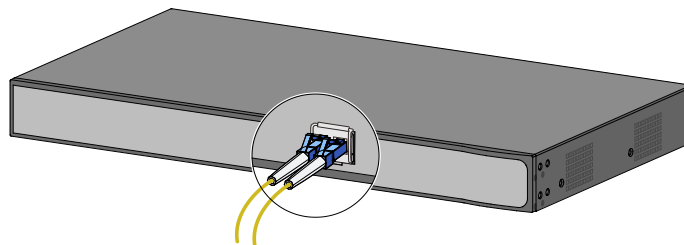

3 Logging in the Device

The default IP address of the switch is 192.168.1.110. You can only log in the device by Console port for first time login. The user name and the password are both "admin", and the baud rate of the serial port is 115200. You can view the actual IP address through **show ip interface** command line.

Login by console port is the most basic way to log in the local interface, and it is also the method to configure other ways to log in the device. You can see the command line manual for details.

Virtual Local Area Network (VLAN) is frequently and widely applied. It is the basic to divide the network. VLAN is the network that multiple devices are logically organized as one network, regardless of the physical location of the devices. Every VLAN is a logical network with all functions and attributes of traditional physical network. Every VLAN is a broadcast domain, and the broadcast packet can only be forwarded within one VLAN. The broadcast packet cannot be forwarded across different VLANs.

Port-based VLAN

Port-based VLAN is that one switch can divide the logical working groups by controlling interoperability between two and several ports. Dividing the port VLAN reasonably can enhance network security, improve bandwidth availability, and reduce the probability of broadcast storm. This series of products support 4094 VLANs. When you create the VLAN, you need to select a VLAN ID which ranges from 2 through 4094. By default, VLAN 1 is created, and it cannot be deleted.

Application Example

Networking Requirement

There are two users, user 1 and user 2. They need to be in different VLANs because the network function and environment they use are different. User 1 belongs to VLAN 2, connected to the switch port G1/1 (GigabitEthernet 1/1). User 2 belongs to VLAN 3, connected to switch port G1/2 (GigabitEthernet 1/2).

Figure 3-1 VLAN networking

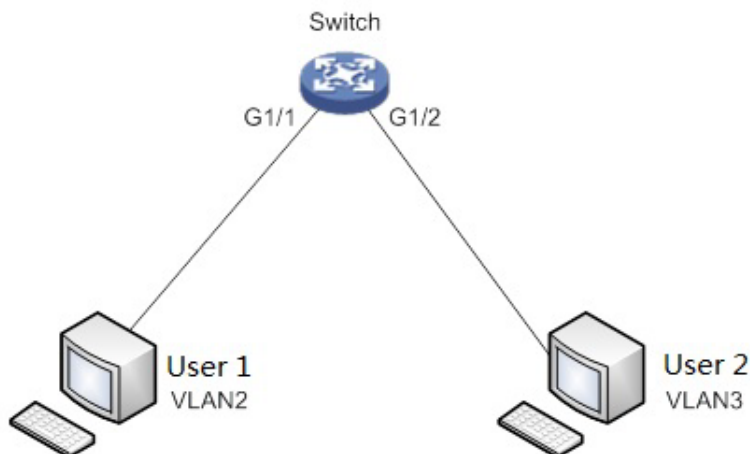

Configuration Procedure

To configure the switch, do the following:

Step 1 Create the VLAN.

```
SWITCH #configure terminal
SWITCH (config)#vlan 2
SWITCH (config-vlan)# exit
SWITCH (config)#vlan 3
SWITCH (config-vlan)# exit
```

Step 2 Allocate the ports into the VLAN.

```
SWITCH(config)# interface GigabitEthernet 1/1
SWITCH (config-if)# switchport access vlan 2
SWITCH (config-if)# exit
SWITCH (config)# interface GigabitEthernet 1/2
SWITCH (config-if)# switchport access vlan 3
SWITCH (config-if)# exit
```

Step 3 Configure the VLAN IP address.

```
SWITCH #configure terminal
SWITCH (config)# interface vlan 2
SWITCH (config-if-vlan)# ip address 192.168.2.1 255.255.255.0
SWITCH (config-if-vlan)#exit
SWITCH (config)#interface vlan 3
SWITCH (config-if-vlan)# ip address 192.168.3.1 255.255.255.0
SWITCH (config-if-vlan)#exit
```

Appendix 1 Cybersecurity Recommendations

Cybersecurity is more than just a buzzword: it's something that pertains to every device that is connected to the internet. IP video surveillance is not immune to cyber risks, but taking basic steps toward protecting and strengthening networks and networked appliances will make them less susceptible to attacks. Below are some tips and recommendations from Dahua on how to create a more secured security system.

Mandatory actions to be taken for basic device network security:

1. Use Strong Passwords

Please refer to the following suggestions to set passwords.

- The length should not be less than 8 characters.
- Include at least two types of characters; character types include upper and lower case letters, numbers and symbols.
- Do not contain the account name or the account name in reverse order.
- Do not use continuous characters, such as 123, abc, etc.
- Do not use overlapped characters, such as 111, aaa, etc.

2. Update Firmware and Client Software in Time

- According to the standard procedure in Tech-industry, we recommend to keep your device (such as NVR, DVR, IP camera, etc.) firmware up-to-date to ensure the system is equipped with the latest security patches and fixes. When the device is connected to the public network, it is recommended to enable the "auto-check for updates" function to obtain timely information of firmware updates released by the manufacturer.
- We suggest that you download and use the latest version of client software.

"Nice to have" recommendations to improve your device network security:

1. Physical Protection

We suggest that you perform physical protection to device, especially storage devices. For example, place the device in a special computer room and cabinet, and implement well-done access control permission and key management to prevent unauthorized personnel from carrying out physical contacts such as damaging hardware, unauthorized connection of removable device (such as USB flash disk, serial port), etc.

2. Change Passwords Regularly

We suggest that you change passwords regularly to reduce the risk of being guessed or cracked.

3. Set and Update Passwords Reset Information Timely

The device supports password reset function. Please set up related information for password reset in time, including the end user's mailbox and password protection questions. If the information changes, please modify it in time. When setting password protection questions, it is suggested not to use those that can be easily guessed.

4. Enable Account Lock

The account lock feature is enabled by default, and we recommend you to keep it on to guarantee the account security. If an attacker attempts to log in with the wrong password several times, the corresponding account and the source IP address will be locked.

5. Change Default HTTP and Other Service Ports

We suggest you to change default HTTP and other service ports into any set of numbers

between 1024–65535, reducing the risk of outsiders being able to guess which ports you are using.

6. Enable HTTPS

We suggest you to enable HTTPS, so that you visit Web service through a secure communication channel.

7. MAC Address Binding

We recommend you to bind the IP and MAC address of the gateway to the device, thus reducing the risk of ARP spoofing.

8. Assign Accounts and Privileges Reasonably

According to business and management requirements, reasonably add users and assign a minimum set of permissions to them.

9. Disable Unnecessary Services and Choose Secure Modes

If not needed, it is recommended to turn off some services such as SNMP, SMTP, UPnP, etc., to reduce risks.

If necessary, it is highly recommended that you use safe modes, including but not limited to the following services:

- SNMP: Choose SNMP v3, and set up strong encryption passwords and authentication passwords.
- SMTP: Choose TLS to access mailbox server.
- FTP: Choose SFTP, and set up strong passwords.
- AP hotspot: Choose WPA2-PSK encryption mode, and set up strong passwords.

10. Audio and Video Encrypted Transmission

If your audio and video data contents are very important or sensitive, we recommend that you use encrypted transmission function, to reduce the risk of audio and video data being stolen during transmission.

Reminder: encrypted transmission will cause some loss in transmission efficiency.

11. Secure Auditing

- Check online users: we suggest that you check online users regularly to see if the device is logged in without authorization.
- Check device log: By viewing the logs, you can know the IP addresses that were used to log in to your devices and their key operations.

12. Network Log

Due to the limited storage capacity of the device, the stored log is limited. If you need to save the log for a long time, it is recommended that you enable the network log function to ensure that the critical logs are synchronized to the network log server for tracing.

13. Construct a Safe Network Environment

In order to better ensure the safety of device and reduce potential cyber risks, we recommend:

- Disable the port mapping function of the router to avoid direct access to the intranet devices from external network.
- The network should be partitioned and isolated according to the actual network needs. If there are no communication requirements between two sub networks, it is suggested to use VLAN, network GAP and other technologies to partition the network, so as to achieve the network isolation effect.
- Establish the 802.1x access authentication system to reduce the risk of unauthorized access to private networks.
- Enable IP/MAC address filtering function to limit the range of hosts allowed to access the device.

More information

Please visit Dahua official website security emergency response center for security announcements and the latest security recommendations.

ENABLING A SAFER SOCIETY AND SMARTER LIVING

ZHEJIANG DAHUA VISION TECHNOLOGY CO., LTD.

Address: No. 1399, Binxing Road, Binjiang District, Hangzhou, P. R. China | Website: www.dahuasecurity.com | Postcode: 310053

Email: dhoverseas@dhvisiontech.com | Tel: +86-571-87688888 28933188