



Z5i

MINI-ITX CASE

User Guide

Product Specifications	
Model	Z5i
Part Number	GC-MKGW1-Z5I
Dimensions (DxWxH)	307.5 x 190 x 417.5mm
Motherboard Compatibility	Mini-ITX
Power Supply Compatibility	SFX
2.5" Drive Bay	2
2.5"/3.5" Drive Bay (Convertible)	1
Front Panel Ports	2x USB 3.0 1x USB 3.1 Type-C
Max GPU Length	≤330mm
Max GPU Slot Size	≤230mm (w/ HDD)
Max CPU Cooler Height	3x PCIe
Side Panels	4mm Tempered Glass
Warranty	2 Years
Cooling Compatibility	
Fans	(Rear) 2x 120mm / 140mm
AIO / Radiator	(Rear) 240mm / 280mm
Package Contents	
Z5i Mini-ITX Case	
PCIe 3.0 Extension Cable	
Accessory Pack	
User Guide	



Accessory Pack Contents

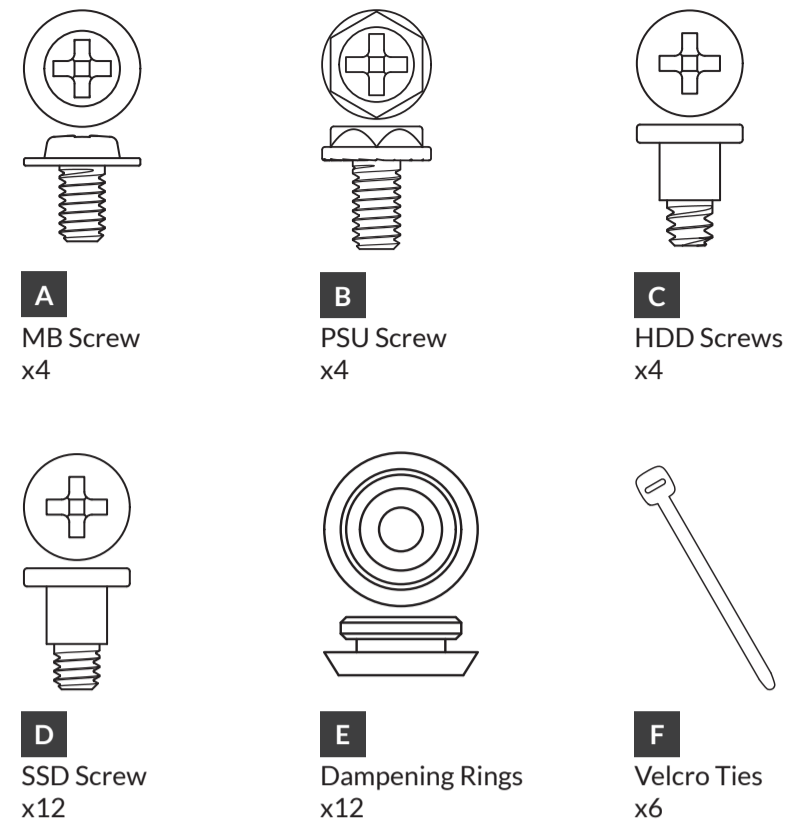

Removing Side Panels

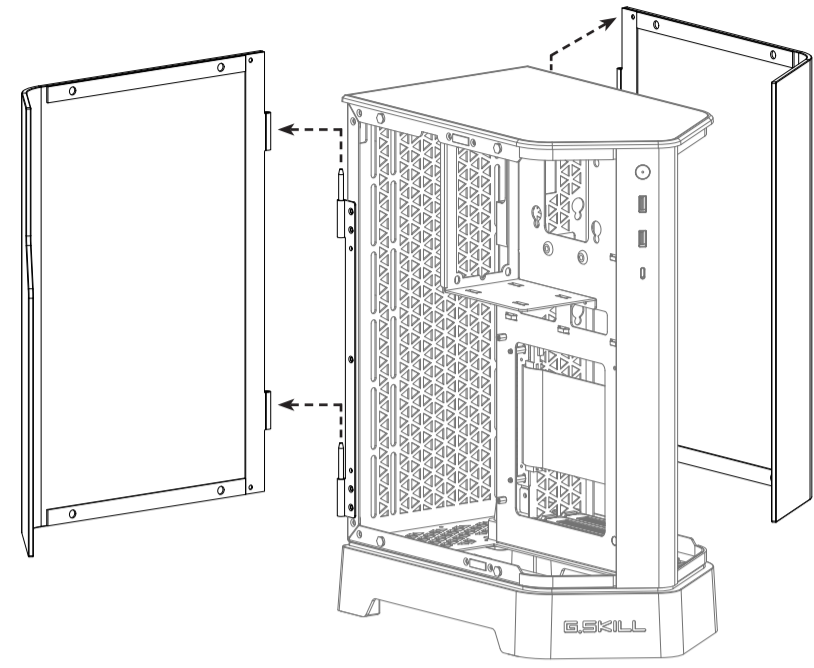

Installing the Motherboard

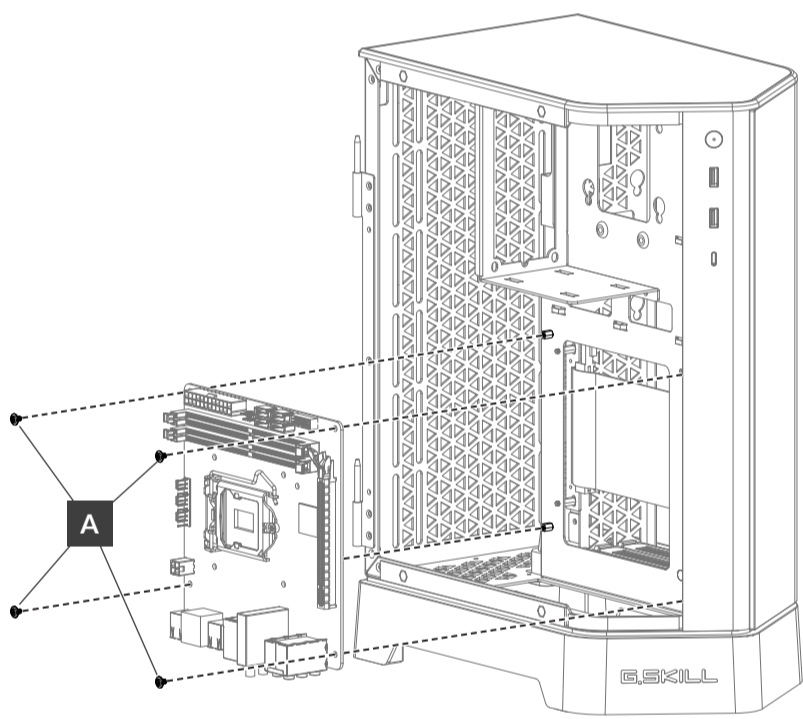

Installing PSU

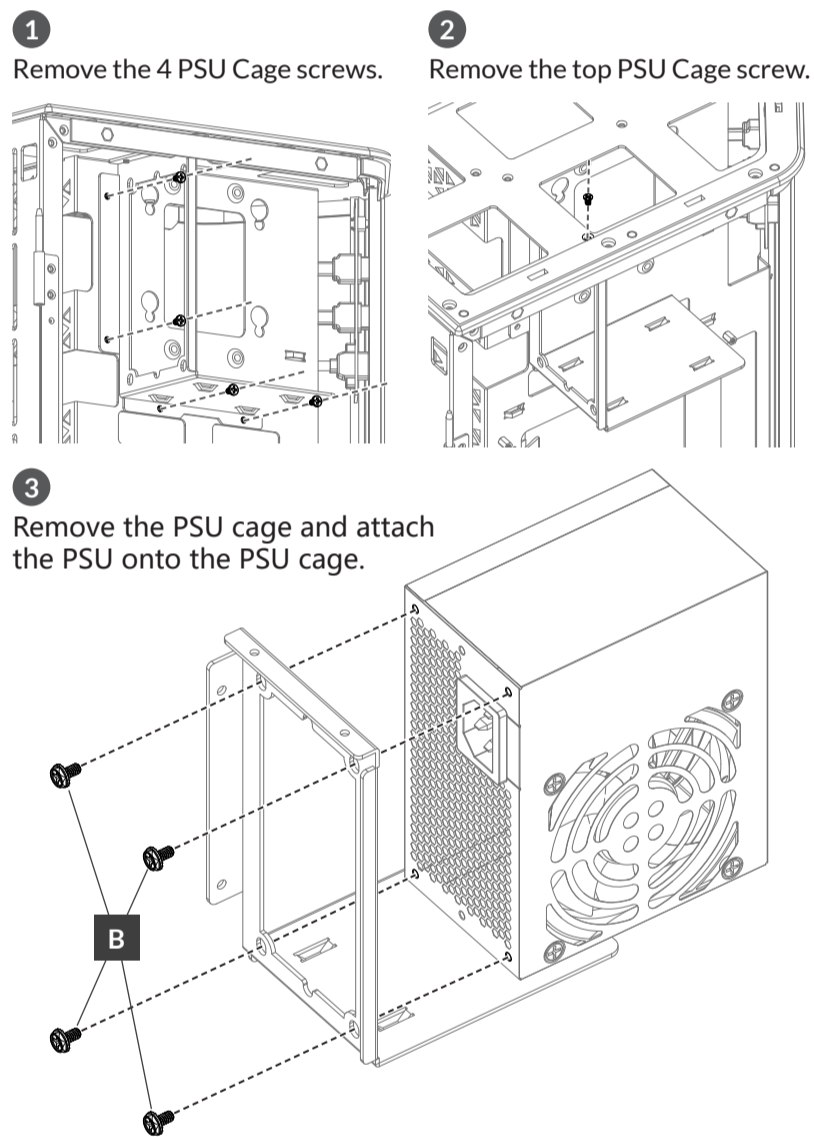

Installing SSDs

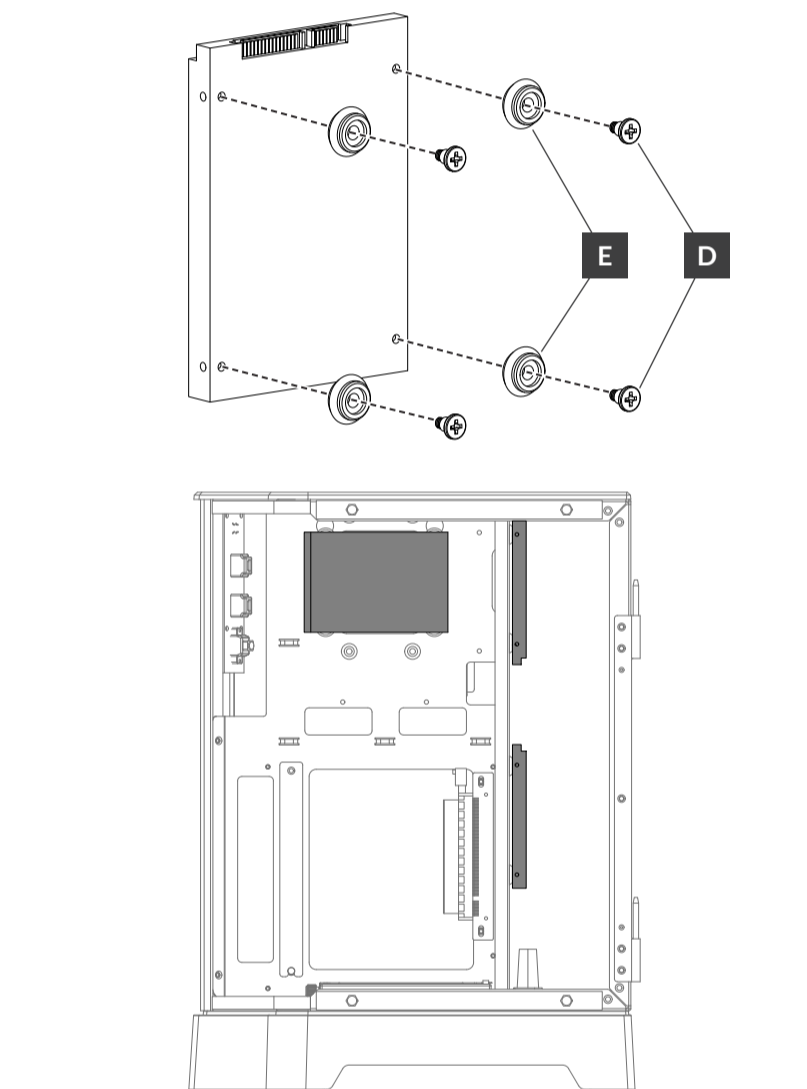

Installing HDD

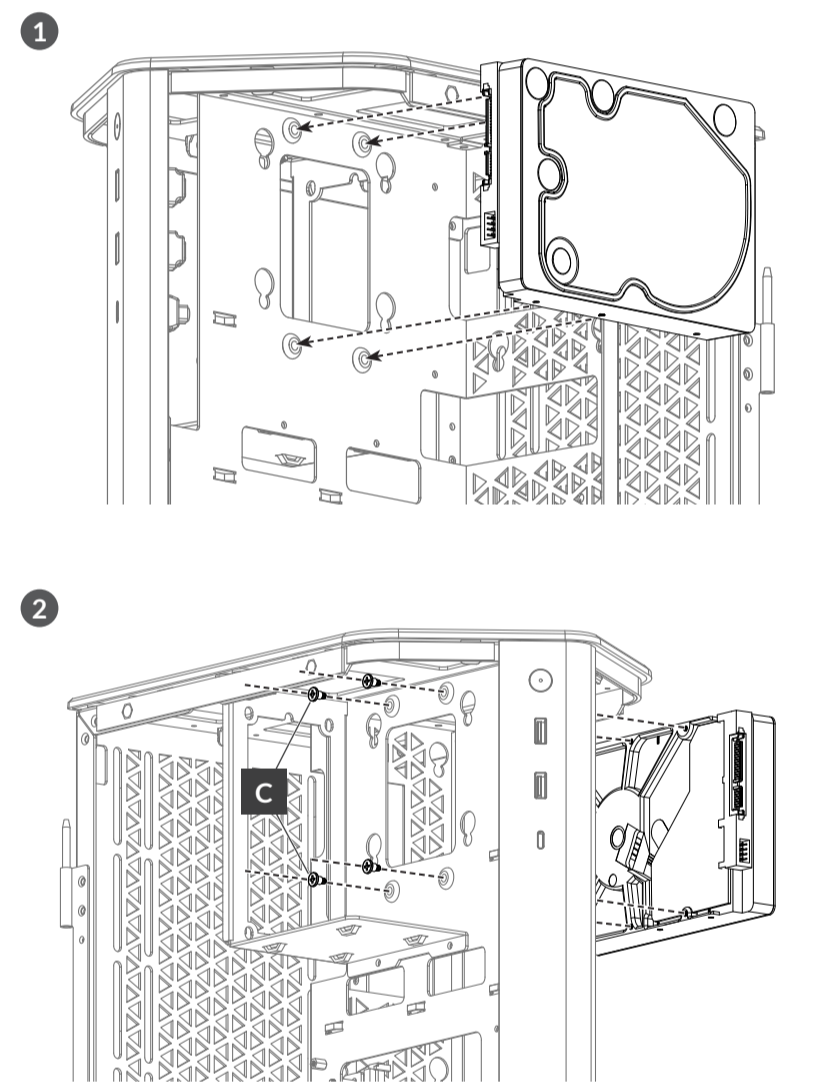

Installing the GPU

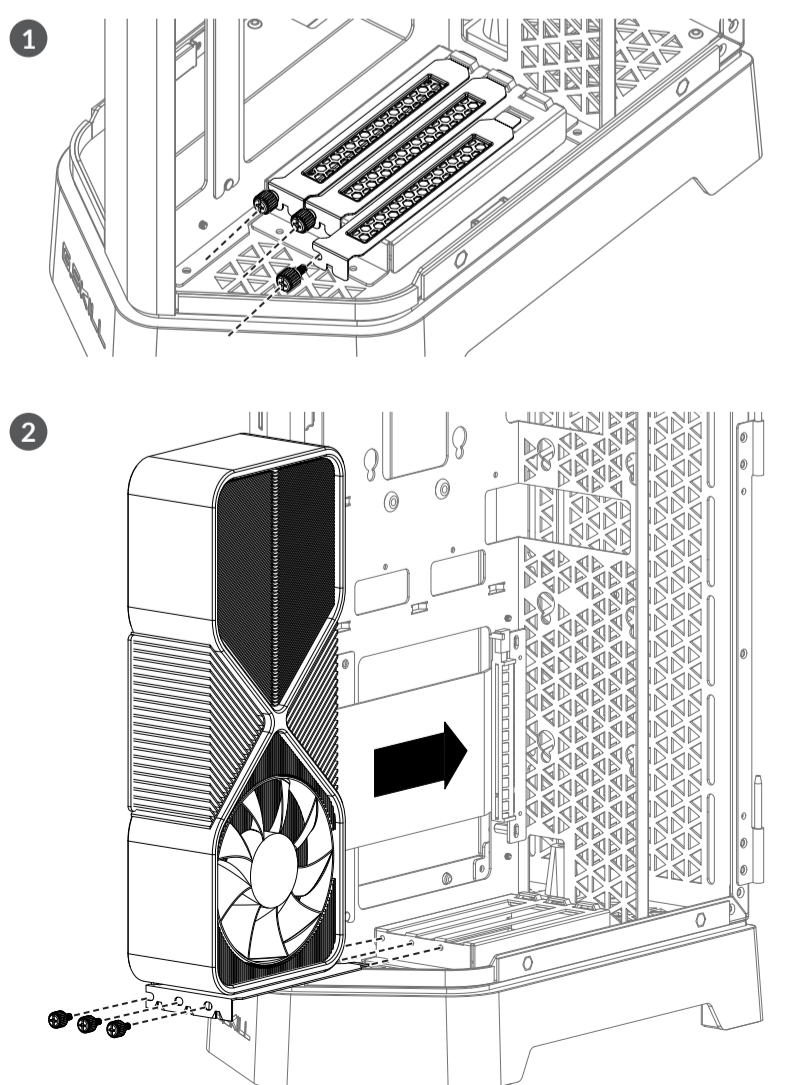

Removing Top Dust Filter

Push from the bottom to detach the dust filter.

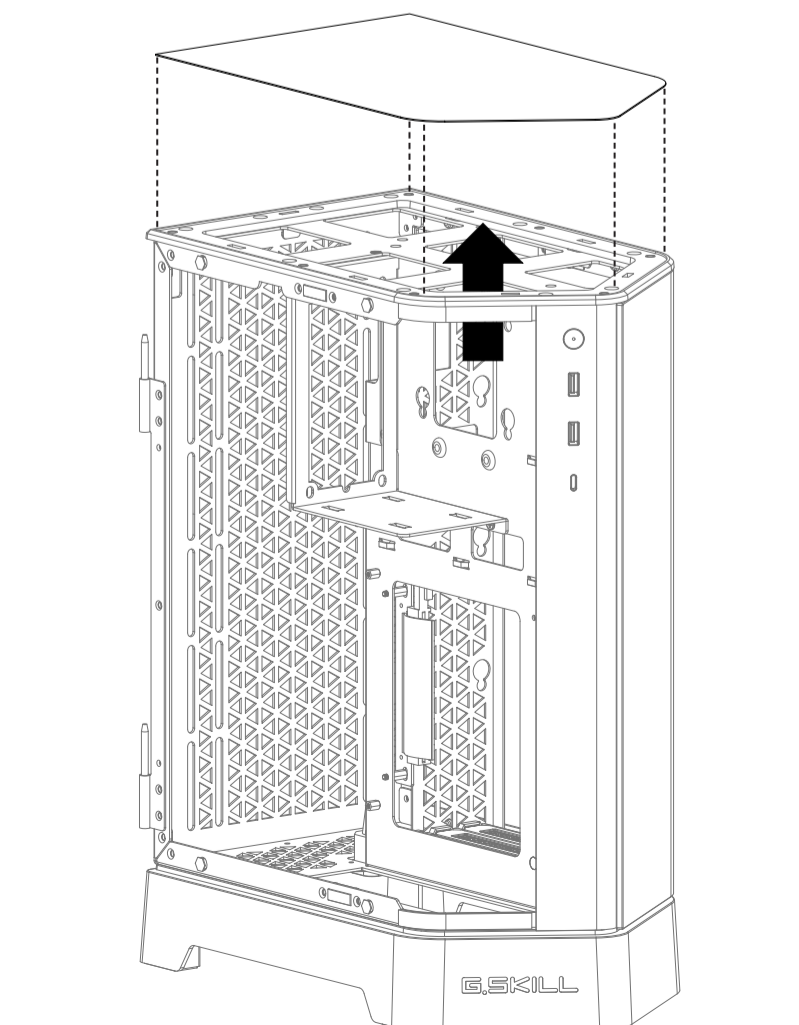

Connectors

Refer to your motherboard manual for front panel and 3-pin 5V RGB header locations and pin-outs.

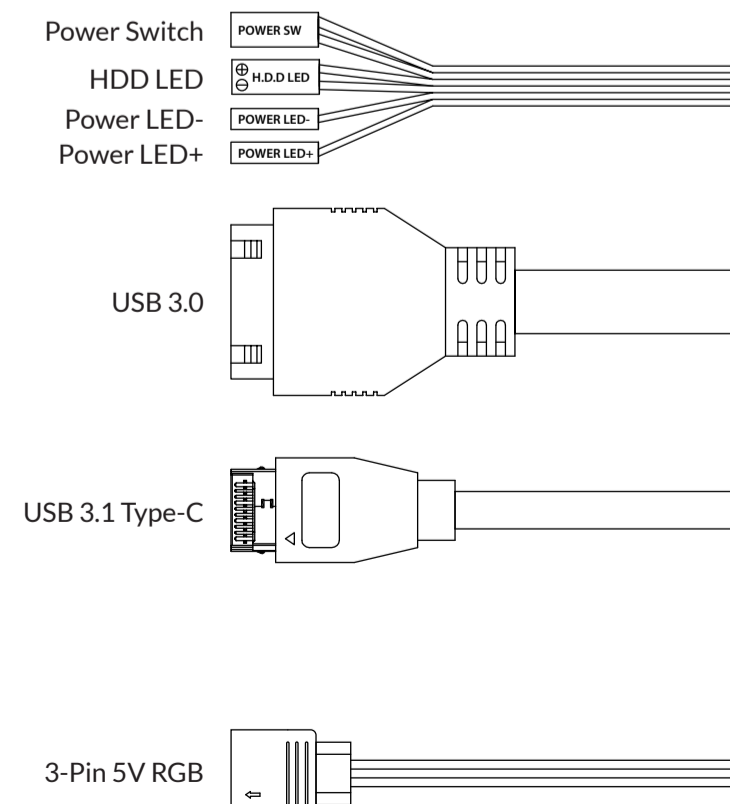

Technical Support

International: techsupport@gskill.com
 North/South America: ustech@gskillusa.com
 Europe: eurotech@gskill.com





Z5i

MINI-ITX 机箱

用户手册

产品规格	
型号	Z5i
编号	GC-MKGW1-Z5i
尺寸 (长x宽x高)	307.5 x 190 x 417.5mm
兼容主板	Mini-ITX
兼容电源	SFX
2.5" 硬盘支持	2
2.5"/3.5" 硬盘 (2选1) 支持	1
面板接口	2x USB 3.0 1x USB 3.1 Type-C
GPU 显卡限长	≤330mm
GPU 显卡限高	≤230mm (w/ HDD)
CPU 散热器限高	≤70mm
侧面板	4mm 钢化玻璃
保固	2年
冷却支持	
风扇	(后) 2x 120mm / 140mm
AIO / 水冷排	(后) 240mm / 280mm
产品内容物	
Z5i Mini-ITX 机箱	
PCIe 3.0 延长线	
配件包	
用户手册	

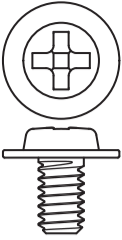
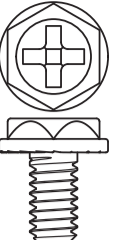
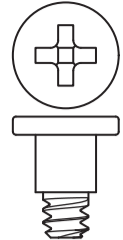
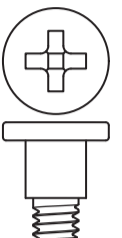

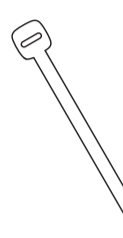
配件包内容		
		
A 主板螺丝 x4	B 电源螺丝 x4	C 机械硬盘螺丝 x4
		
D 固态硬盘螺丝 x12	E 固态硬盘防震垫 x12	F 扎线带 x6

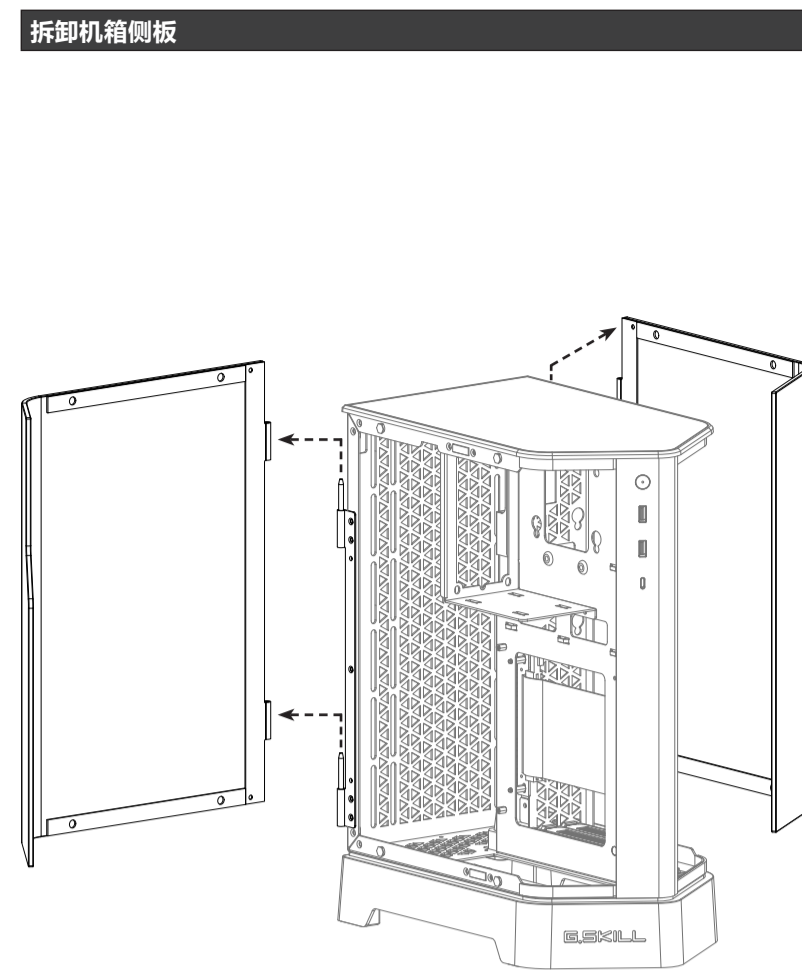

安装主板

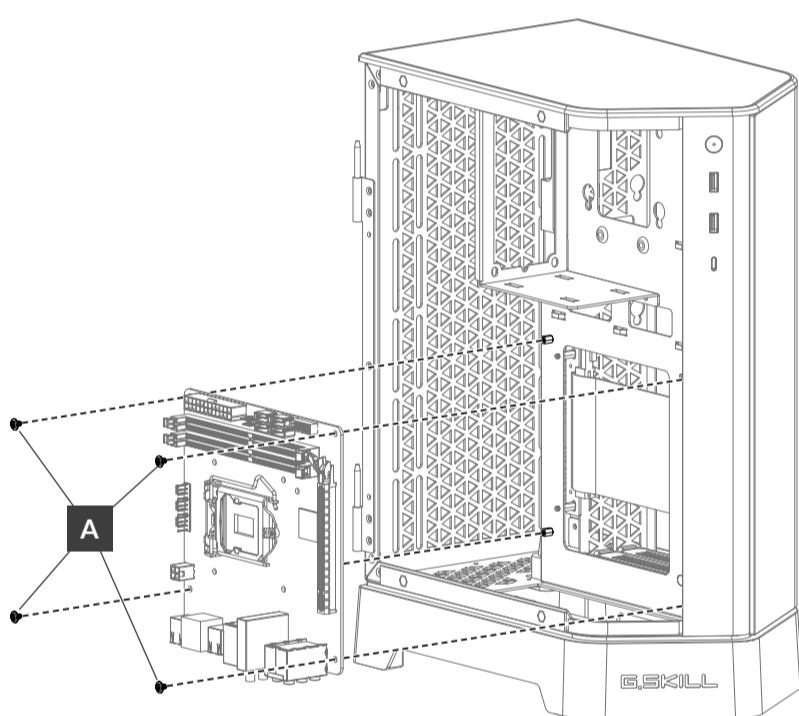

安装电源

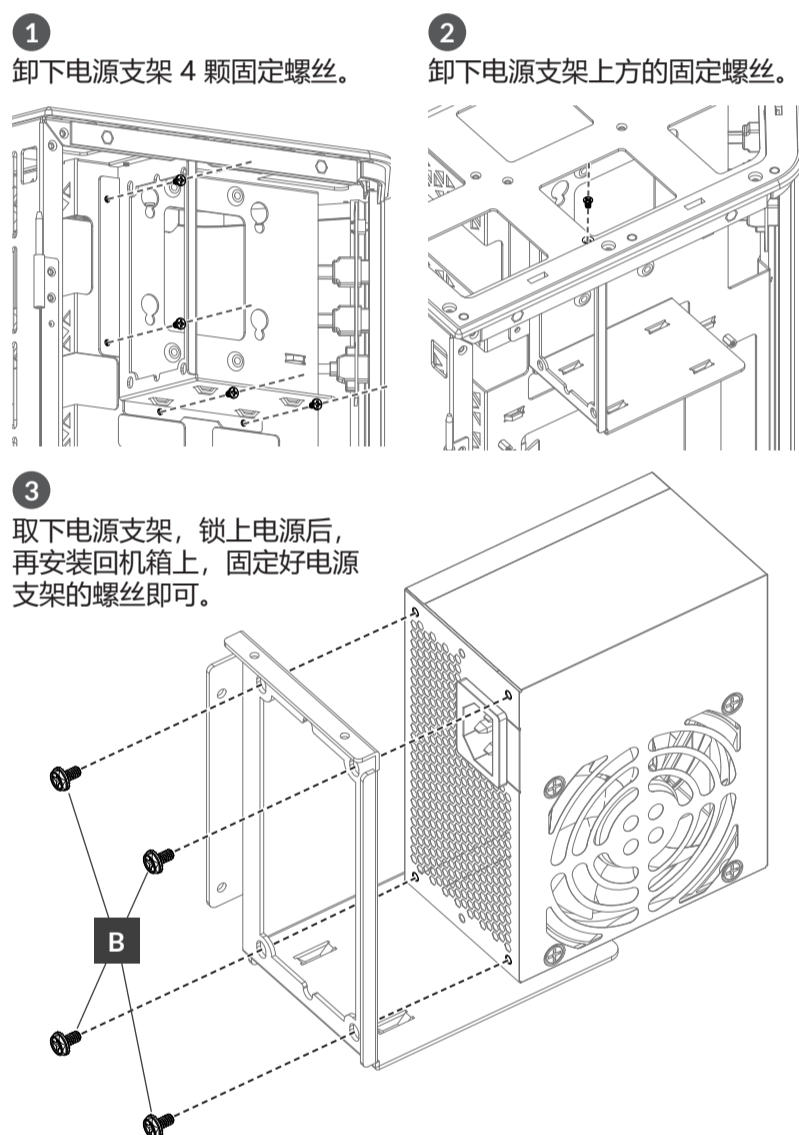

安装固态硬盘

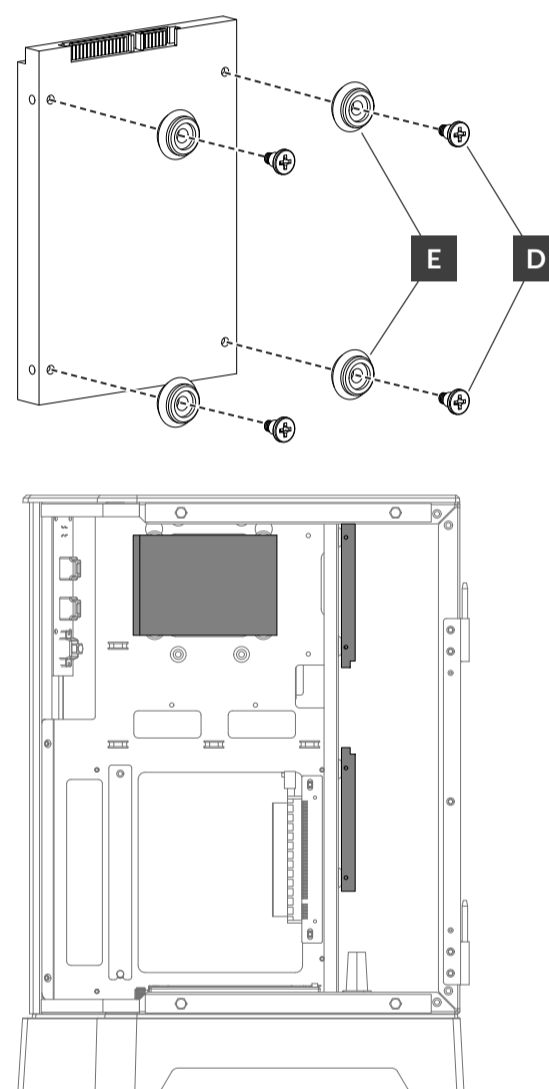

安装机械硬盘

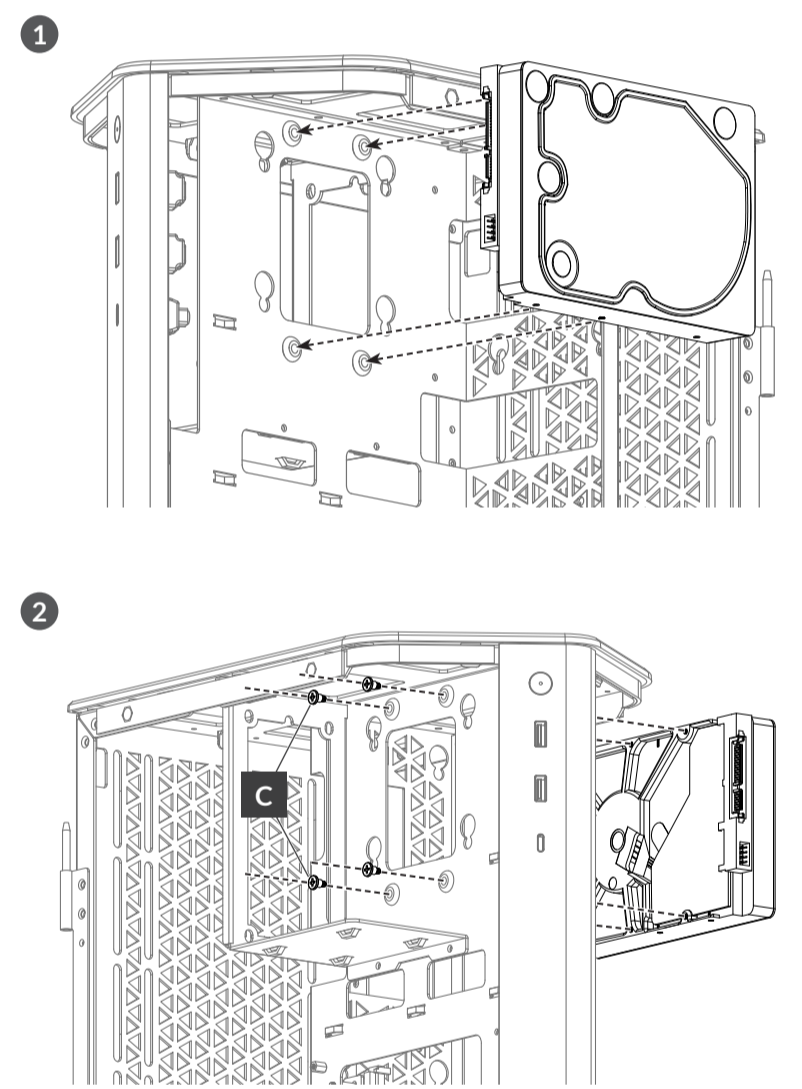

安装显卡

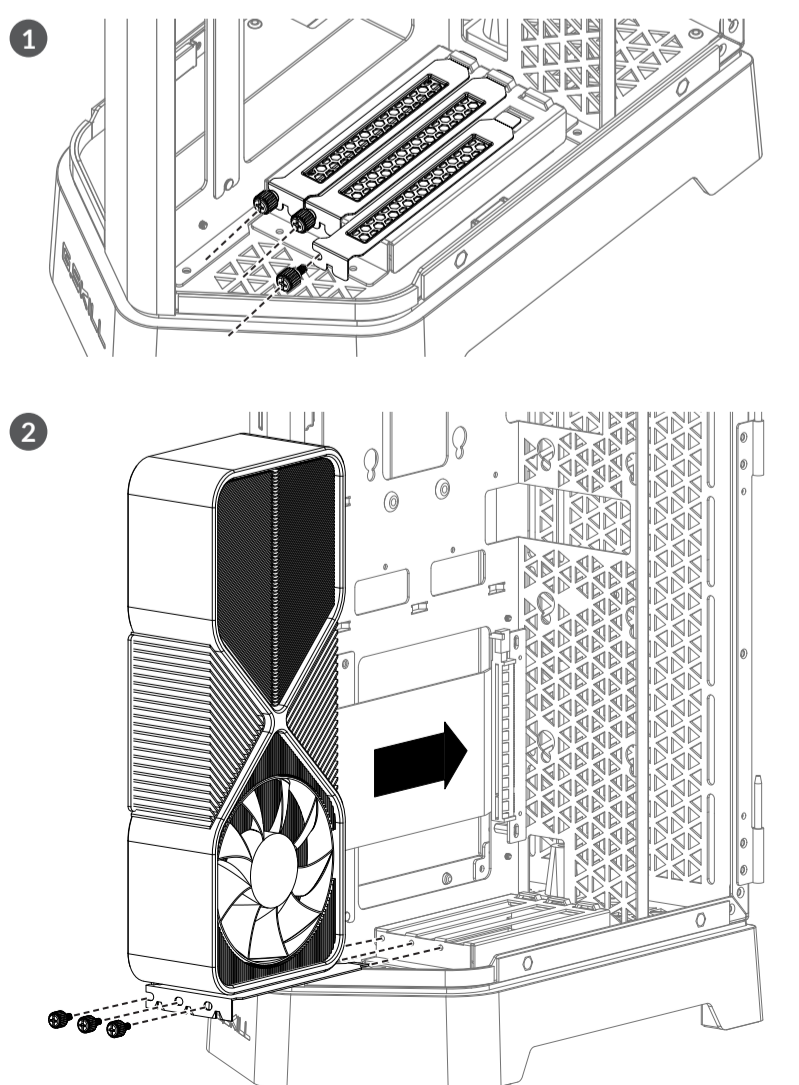

打开上方风扇滤网

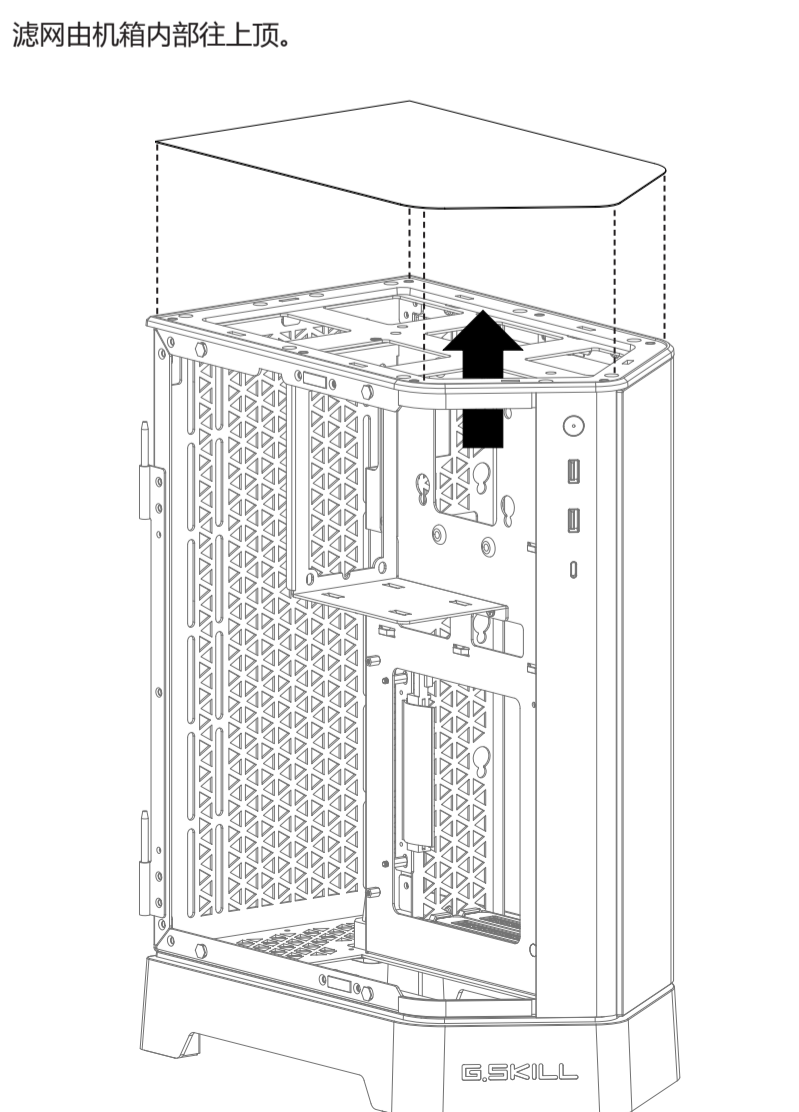

接口

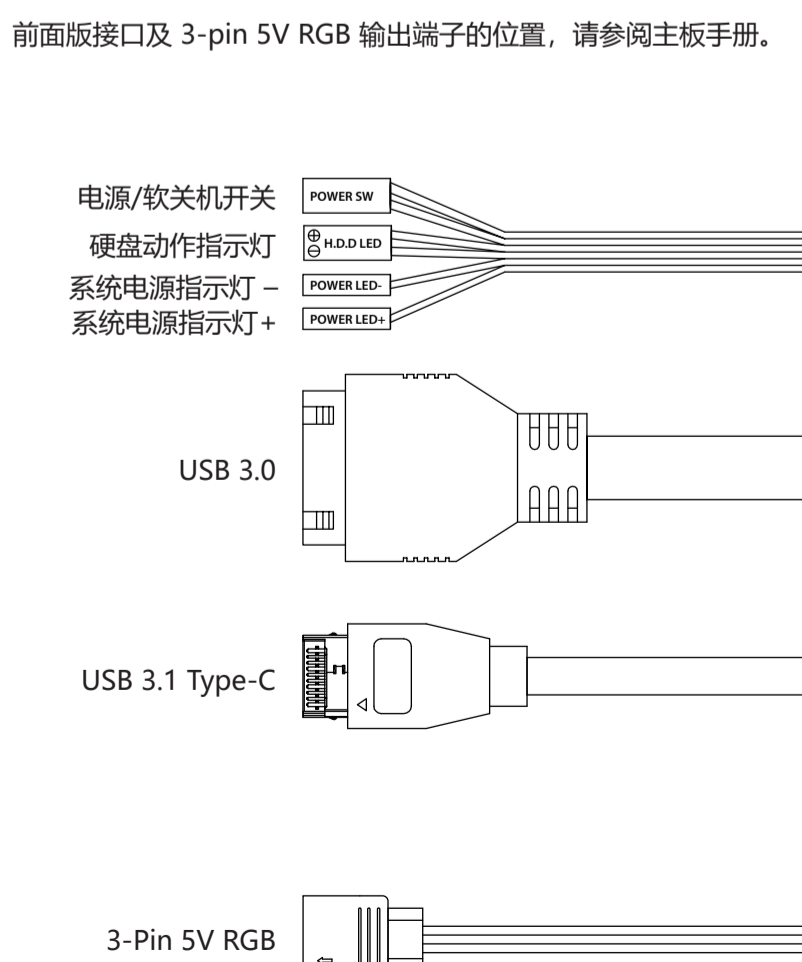

技术支持

全球：techsupport@gskill.com
 美洲：ustech@gskillusa.com
 欧洲：eurotech@gskill.com