

ASRock®

TRX50 WS

User Manual

Contact Information

If you need to contact ASRock or want to know more about ASRock, you're welcome to visit ASRock's website at <http://www.asrock.com>; or you may contact your dealer for further information. For technical questions, please submit a support request form at <https://event.asrock.com/tsd.asp>

ASRock Incorporation

e-mail: info@asrock.com.tw

ASRock EUROPE B.V.

e-mail: sales@asrock.nl

ASRock America, Inc.

e-mail: sales@asrockamerica.com



Scan the QR code to view more manuals and documents.

Contents

Chapter 1 Introduction	1
1.1 Package Contents	1
1.2 Specifications	2
1.3 Motherboard Layout	7
1.4 I/O Panel	10
1.5 Block Diagram	12
1.6 802.11ax Wi-Fi 6E Module and ASRock WiFi 2.4/5/6 GHz Antenna	13
Chapter 2 Installation	14
2.1 Installing the CPU	15
2.2 Installing the CPU Liquid Cooler	19
2.3 Installing Memory Modules (DIMM)	21
2.4 Connecting the Front Panel Header	23
2.5 Installing the Motherboard	24
2.6 Installing SATA Drives	25
2.7 Installing a Graphics Card	27
2.8 Connecting Peripheral Devices	29
2.9 Connecting the Power Connectors	30
2.10 Power On	31
2.11 Jumpers Setup	32
2.12 Onboard Headers and Connectors	33

2.13	Smart Buttons	54
2.14	Dr. Debug	58
2.15	M.2 SSD Card Installation Guide (M2_1)	64
2.16	M.2 SSD Card Installation Guide (M2_2)	67

Chapter 1 Introduction

Thank you for purchasing ASRock TRX50 WS motherboard, a reliable motherboard produced under ASRock's consistently stringent quality control. It delivers excellent performance with robust design conforming to ASRock's commitment to quality and endurance.



Because the motherboard specifications and the BIOS software might be updated, the content of this documentation will be subject to change without notice. In case any modifications of this documentation occur, the updated version will be available on ASRock's website without further notice. If you require technical support related to this motherboard, please visit our website for specific information about the model you are using. You may find the latest VGA cards and CPU support list on ASRock's website as well. ASRock website <http://www.asrock.com>.

1.1 Package Contents

- ASRock TRX50 WS Motherboard (EATX Form Factor)
- ASRock TRX50 WS User Manual
- 4 x Serial ATA (SATA) Data Cables (Optional)
- 1 x ASRock WiFi 2.4/5/6 GHz Antenna (Optional)
- 2 x Thermistor Cables (Optional)
- 1 x Multi PSU Adaptor Cable (Optional)
- 2 x Screws for M.2 Sockets (Optional)
- 2 x Standoffs for M.2 Sockets (Optional)

1.2 Specifications

- Platform**
- EATX Form Factor
 - 12 Layer PCB
 - 2oz Copper PCB

- CPU**
- Supports AMD Ryzen™ Threadripper™ PRO 7000 and AMD Ryzen™ Threadripper™ 7000 Series Processors
 - Supports AMD Socket sTR5
 - Supports ASRock Hyper BCLK Engine

- Chipset**
- AMD TRX50

- Memory**
- Quad Channel DDR5 Memory Technology
 - 4 x DDR5 DIMM Slots
 - Supports DDR5 ECC, buffered memory (RDIMM/ RDIMM-3DS) up to 7600+(OC)*
 - Max. capacity of system memory: 1TB
- * Please refer to Memory Support List on ASRock's website for more information. (<http://www.asrock.com/>)

- Expansion Slot**
- CPU:
- 3 x PCIe 5.0 x16 Slots (PCIE1/PCIE3 at x16; PCIE4 at x8)*
 - 1 x PCIe 4.0 x16 Slot (PCIE2), supports x4 mode*
 - 1 x PCIe 4.0 x16 Slot (PCIE5), supports x8 mode*
- Chipset:
- 1 x M.2 Socket (Key E), supports type 2230 WiFi/BT PCIe WiFi module

- * Supports NVMe SSD as boot disks
- 15μ Gold Contact in VGA PCIe Slots

- Audio**
- 7.1 CH HD Audio with Content Protection (Realtek ALC1220 Audio Codec)
 - Impedance Sensing on Rear Out port
 - Individual PCB Layers for R/L Audio Channel
 - Nahimic Audio

- LAN**
- 1 x 10 Gigabit LAN 100/1000/2500/5000/10000 Mb/s (Marvell AQC113)**
 - Support Wake-On-LAN
 - Support PXE
 - 1 x 2.5 Gigabit LAN 10/100/1000/2500 Mb/s (Dragon RTL-8125BG)**
 - Supports Dragon 2.5G LAN Software
 - Smart Auto Adjust Bandwidth Control
 - Visual User Friendly UI
 - Visual Network Usage Statistics
 - Optimized Default Setting for Game, Browser, and Streaming Modes
 - User Customized Priority Control

Wireless LAN

- 802.11ax Wi-Fi 6E Module
 - Supports IEEE 802.11a/b/g/n/ac/ax
 - Supports Dual-Band 2x2 with extended 6GHz band* support
- * Wi-Fi 6E (6GHz band) will be supported by Microsoft® Windows® 11. The availability will depend on the different regulation status of each country and region. It will be activated (for supported countries) through Windows Update and software updates once available.
- * A 6GHz compatible router is required for 6E functionality.
 - 2 antennas to support 2 (Transmit) x 2 (Receive) diversity technology
 - Supports Bluetooth 5.2 + High speed class II
 - Supports MU-MIMO

USB

- CPU:
- 1 x USB 3.2 Gen2x2 Type-C (Rear)
 - 4 x USB 3.2 Gen2 Type-A (Rear)
- Chipset:
- 2 x USB 3.2 Gen2 Type-C (1 Rear, 1 Front)
 - 4 x USB 3.2 Gen1 Type-A (2 Rear, 2 Front)
 - 4 x USB 2.0 (Front)
- * All USB ports support ESD Protection

Rear Panel I/O

- 2 x Antenna Ports
- 1 x Optical SPDIF Out Port
- 1 x USB 3.2 Gen2x2 Type-C Port (20 Gb/s)
- 4 x USB 3.2 Gen2 Type-A Ports (10 Gb/s)
- 1 x USB 3.2 Gen2 Type-C Port (10 Gb/s)
- 2 x USB 3.2 Gen1 Type-A Ports
- 2 x RJ-45 LAN Ports
- 1 x Clear CMOS Button
- 1 x BIOS Flashback Button
- 1 x Line Out Jack (Gold Audio Jack)
- 1 x Microphone Input Jack (Gold Audio Jack)

Storage

CPU:

- 1 x Blazing M.2 Socket (M2_1, Key M), supports type 2260/2280 PCIe Gen5x4 mode*
- 1 x MCIO PCIe Gen5x4 Connector
- 2 x SlimSAS SFF-8654 Connectors (PCIe Gen4x4 or 4 x SATA3 6.0 Gb/s)

Chipset:

- 1 x Hyper M.2 Socket (M2_2, Key M), supports type 2260/2280 PCIe Gen4x4 mode*
- 4 x SATA3 6.0 Gb/s Connectors

* Supports NVMe SSD as boot disks

RAID

- Supports RAID 0, RAID 1 and RAID 10 for SATA storage devices
- Supports RAID 0, RAID 1 and RAID 10 for M.2 NVMe storage devices*

* Requires additional M.2 NVMe expansion cards to support RAID 10

Connector

- 2 x Thermistor Cable Headers
- 1 x SPI TPM Header
- 1 x COM Port Header
- 1 x Chassis Intrusion and Speaker Header
- 2 x Addressable LED Headers*
- 1 x CPU Fan Connector (4-pin)**

- 1 x CPU/Water Pump Fan Connector (4-pin) (Smart Fan Speed Control)**
- 3 x Chassis/Water Pump Fan Connectors (4-pin) (Smart Fan Speed Control)****
- 1 x 24 pin ATX Power Connector (Hi-Density Power Connector)
- 1 x 3 pin ATX Power Connector*****
- 2 x 8 pin ATX 12V Power Connectors (Hi-Density Power Connector) (for Motherboard)*****
- 2 x 6 pin PCIe 12V Power Connectors (Hi-Density Power Connector) (for Motherboard)*****
- 1 x 6 pin Graphics 12V Power Connector (Hi-Density Power Connector) (for PCIe card)*****
- 1 x Front Panel Audio Connector (15μ Gold Audio Connector)
- 1 x Thunderbolt AIC Connector (5-pin) (Supports ASRock Thunderbolt 4 AIC Card)
- 2 x USB 2.0 Headers (Support 4 USB 2.0 ports)
- 1 x USB 3.2 Gen1 Header (Supports 2 USB 3.2 Gen1 ports)
- 1 x Front Panel Type C USB 3.2 Gen2 Header (10 Gb/s)
- 1 x Dr. Debug with LED
- 1 x Power Button with LED
- 1 x Reset Button with LED

* Support in total up to 5V/3A, 15W LED Strip

** CPU_FAN1 supports the fan power up to 1A (12W).

*** CPU_FAN2/WP supports the fan power up to 2A (24W).

**** CHA_FAN1~3/WP support the fan power up to 2A (24W).

***** Plug the Multi PSU Adaptor Cable that comes with the package to ATX_CON1 if you use a secondary PSU.

***** It is required to connect both ATX12V1 and ATX12V2; otherwise, the system may not boot up properly.

***** It is required to connect all 8 pin and 6 pin 12V Power Connectors when overclocking.

***** It is required to connect a 6 pin PCIe 12V power cable to GFX_12V1; otherwise, the system may not boot up properly.

BIOS Feature

- AMI UEFI Legal BIOS with GUI support

OS

- Microsoft® Windows® 11 64-bit

**Certifica-
tions**

- FCC, CE
- ErP/EuP ready (ErP/EuP ready power supply is required)

* For detailed product information, please visit our website: <http://www.asrock.com>



Please realize that there is a certain risk involved with overclocking, including adjusting the setting in the BIOS, applying Untied Overclocking Technology, or using third-party overclocking tools. Overclocking may affect your system's stability, or even cause damage to the components and devices of your system. It should be done at your own risk and expense. We are not responsible for possible damage caused by overclocking.

No.	Description
1	8 pin ATX 12V Power Connector (ATX12V2)
2	6 pin PCIe 12V Power Connector (PCIe12V2_6P)
3	Chassis/Water Pump Fan Connector (CHA_FAN2/WP)
4	SPI TPM Header (TPM_BIOS_PH1)
5	Reset Button (RSTBTN1)
6	Power Button (PWRBTN1)
7	CPU/Water Pump Fan Connector (CPU_FAN2/WP)
8	CPU Fan Connector (CPU_FAN1)
9	Addressable LED Header (ADDR_LED2)
10	6 pin PCIe 12V Power Connector (PCIe12V1_6P)
11	8 pin ATX 12V Power Connector (ATX12V1)
12	2 x 288-pin DDR5 DIMM Slots (DDR5_G0, DDR5_E0)
13	ATX Power Connector (ATXPWR1)
14	3 pin ATX Power Connector Connector (ATX_CON1)
15	2 x 288-pin DDR5 DIMM Slots (DDR5_A0, DDR5_C0)
16	Front Panel Type C USB 3.2 Gen2 Header (USB32_TC3)
17	Mini Cool Edge IO Connector (MCIO1)
18	SlimSAS Connector (SLIM2)
19	SlimSAS Connector (SLIM1)
20	SATA3 Connectors (SATA3_2)(Upper), (SATA3_1)(Lower)
21	SATA3 Connectors (SATA3_4)(Upper), (SATA3_3)(Lower)
22	6 pin Graphics 12V Power Connector (GFX_12V1)
23	Chassis/Water Pump Fan Connector (CHA_FAN3/WP)
24	System Panel Header (PANEL1)
25	Chassis Intrusion and Speaker Header (SPK_CI1)
26	Thermistor Cable Header (T_SENSOR1)
27	Thermistor Cable Header (T_SENSOR2)
28	USB 2.0 Header (USB_3_4)
29	USB 2.0 Header (USB_1_2)
30	USB 3.2 Gen1 Header (USB32_7_8)
31	Clear CMOS Jumper (CLRCMOS1)
32	Chassis/Water Pump Fan Connector (CHA_FAN1/WP)
33	Addressable LED Header (ADDR_LED1)

No. Description

- 34 5-pin Thunderbolt AIC Connector (TB1)
- 35 COM Port Header (COM1)
- 36 Front Panel Audio Header (HD_AUDIO1)

1.4 I/O Panel

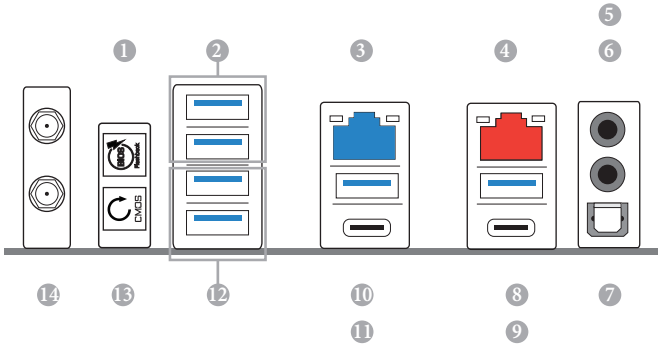

No.	Description	No.	Description
1	BIOS Flashback Button	9	USB 3.2 Gen2x2 Type-C Port
2	USB 3.2 Gen1 Type-A Ports (USB32_34)	10	USB 3.2 Gen2 Type-A Port (USB32_5)
3	2.5G LAN RJ-45 Port (Dragon RTL8125BG)*	11	USB 3.2 Gen2 Type-C Port (USB32_TC1)
4	10G LAN RJ-45 Port (Marvell AQC113)**	12	USB 3.2 Gen2 Type-A Ports (USB32_12)
5	Microphone Input Jack***	13	Clear CMOS Button
6	Line Out Jack***	14	Antenna Ports
7	Optical SPDIF Out Port		
8	USB 3.2 Gen2 Type-A Port (USB32_6)		

* There are two LEDs on each LAN port. Please refer to the table below for the LAN port LED indications.

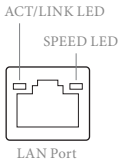

Activity / Link LED		Speed LED	
Status	Description	Status	Description
Off	No Link	Off	10Mbps connection
Blinking	Data Activity	Orange	100Mbps/1Gbps connection
On	Link	Green	2.5Gbps connection

**There are two LEDs on each LAN port. Please refer to the table below for the LAN port LED indications.

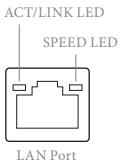

Activity / Link LED		Speed LED	
Status	Description	Status	Description
Off	No Link		100Mbps/1Gbps/2.5Gbps
Blinking	Data Activity	Orange	/5Gbps connection
On	Link	Green	10Gbps connection

*** Function of the Audio Ports in 2, 4, 5.1 or 7.1-channel Configuration:

Channel	Port	Function
2ch	Line Out Jack (Rear Panel)	Front speaker out
4ch	Pink-Mic (Front Panel)	Rear speaker out
5.1ch	Microphone Input Jack (Rear Panel)	Central/Subwoofer speaker out
7.1ch	Lime-Headphone (Front Panel)	Side Speaker out

1.5 Block Diagram

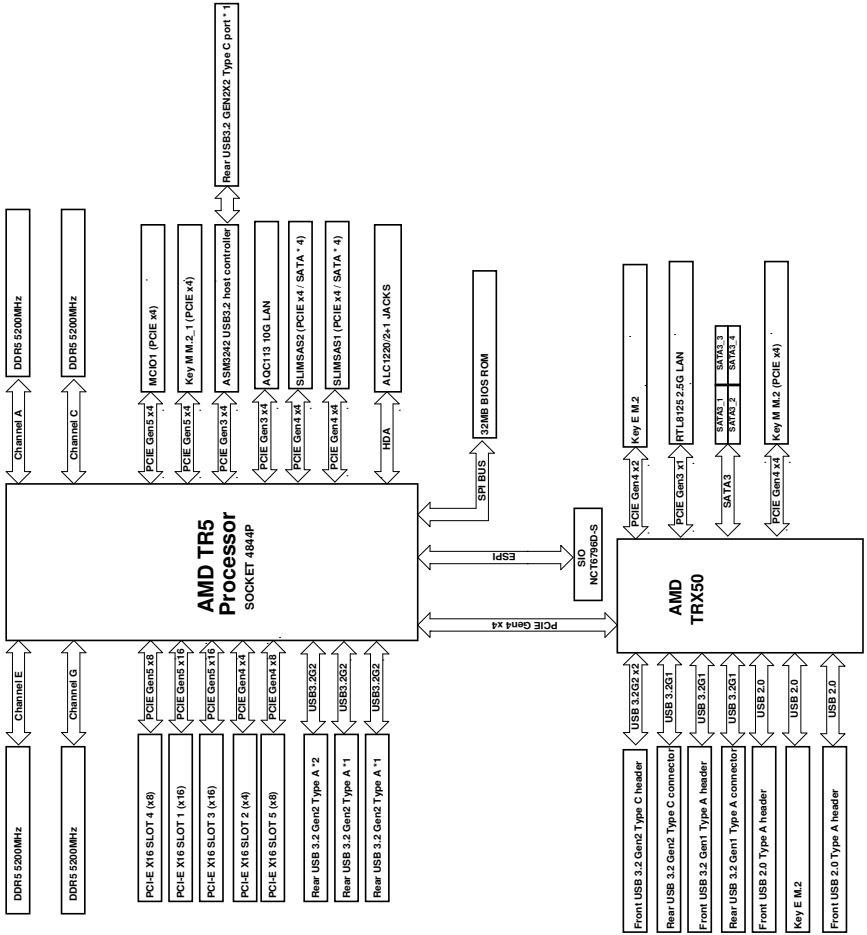

1.6 802.11ax Wi-Fi 6E Module and ASRock WiFi 2.4/5/6 GHz Antenna

802.11ax Wi-Fi 6E + BT Module

This motherboard comes with an exclusive 802.11 a/b/g/n/ac/ax Wi-Fi 6E + BT v5.2 module that offers support for 802.11 a/b/g/n/ac/ax Wi-Fi 6E connectivity standards and Bluetooth v5.2. Wi-Fi 6E + BT module is an easy-to-use wireless local area network (WLAN) adapter to support Wi-Fi 6E + BT. Bluetooth v5.2 standard features Smart Ready technology that adds a whole new class of functionality into the mobile devices. BT 5.2 also includes Low Energy Technology and ensures extraordinary low power consumption for PCs.

- * The transmission speed may vary according to the environment.
- * Wi-Fi 6E (6GHz band) will be supported by Microsoft® Windows® 11. The availability will depend on the different regulation status of each country and region. It will be activated (for supported countries) through Windows Update and software updates once available.
- * A 6GHz compatible router is required for 6E functionality.

Chapter 2 Installation

This is an EATX form factor motherboard. Before you install the motherboard, study the configuration of your chassis to ensure that the motherboard fits into it.

Pre-installation Precautions

Take note of the following precautions before you install motherboard components or change any motherboard settings.

- Make sure to unplug the power cord before installing or removing the motherboard components. Failure to do so may cause physical injuries and damages to motherboard components.
- In order to avoid damage from static electricity to the motherboard's components, NEVER place your motherboard directly on a carpet. Also remember to use a grounded wrist strap or touch a safety grounded object before you handle the components.
- Hold components by the edges and do not touch the ICs.
- Whenever you uninstall any components, place them on a grounded anti-static pad or in the bag that comes with the components.
- When placing screws to secure the motherboard to the chassis, please do not over-tighten the screws! Doing so may damage the motherboard.

2.1 Installing the CPU



Unplug all power cables before installing the CPU.

1

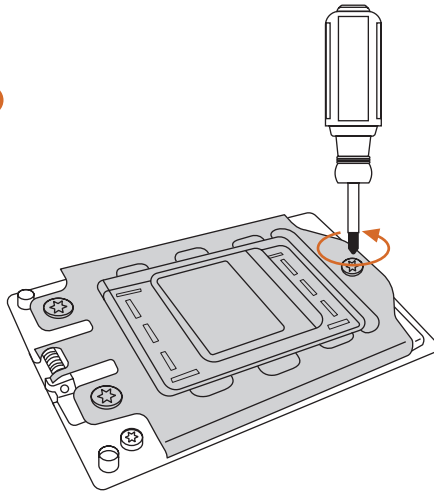

2

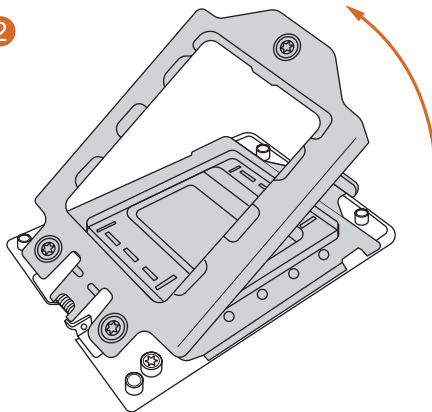

3

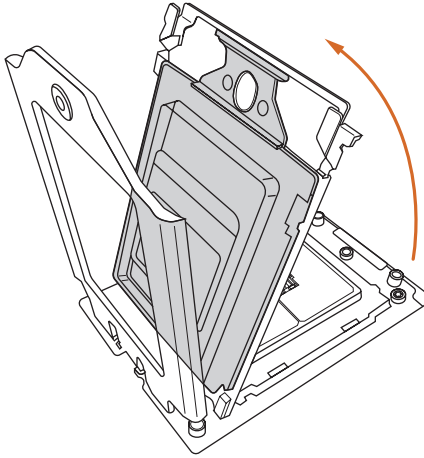

4

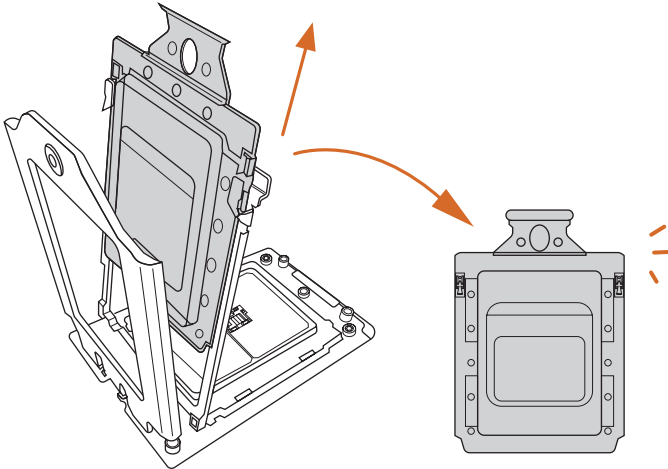

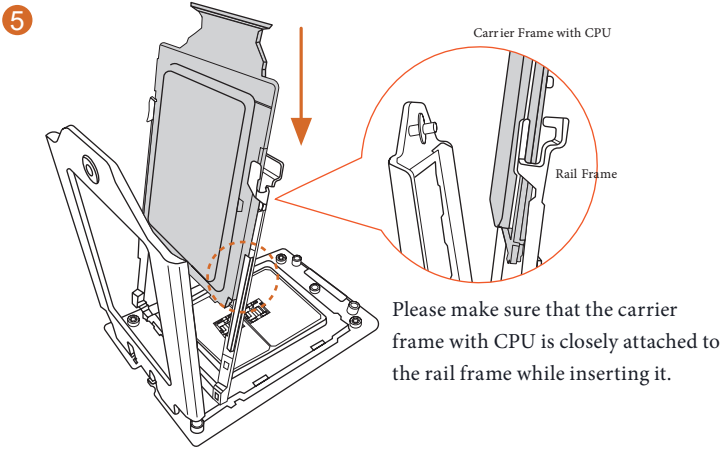

Install the orange carrier frame with CPU. Don't separate them.

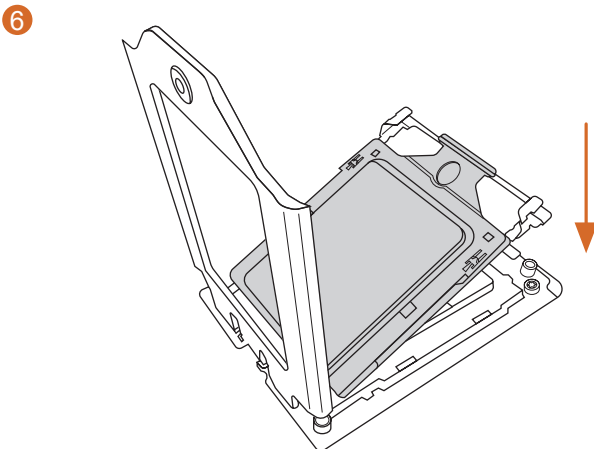

7

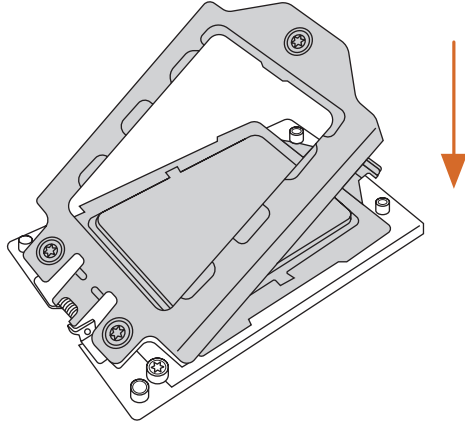

8

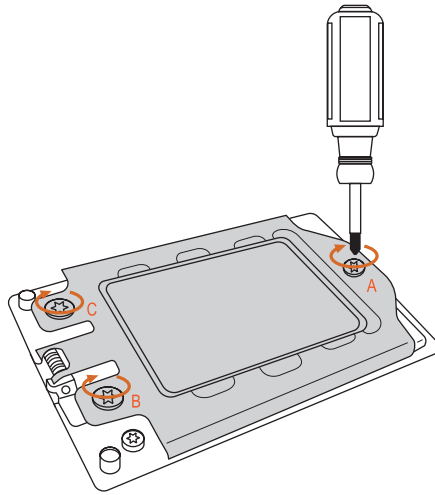

2.2 Installing the CPU Liquid Cooler

After you install the CPU into this motherboard, it is necessary to install a larger heatsink and cooling fan to dissipate heat. You also need to spray thermal grease between the CPU and the heatsink to improve heat dissipation. Make sure that the CPU and the heatsink are securely fastened and in good contact with each other.



Please turn off the power or remove the power cord before changing a CPU or heatsink.

1

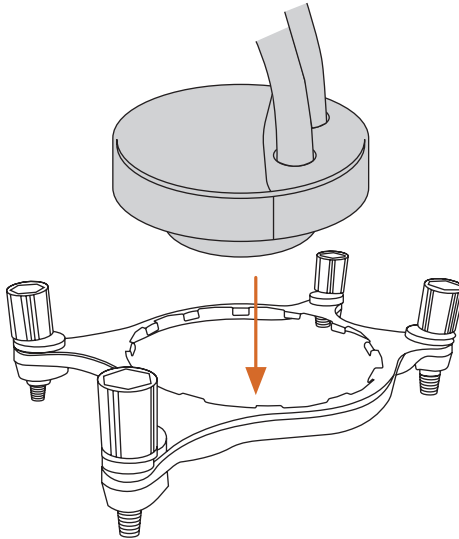

2

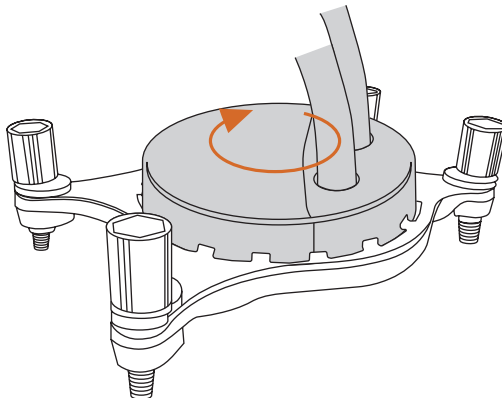

3

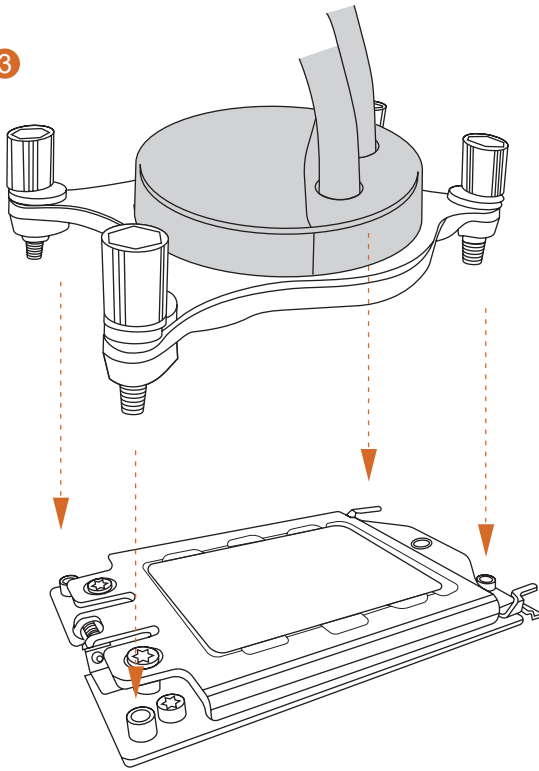

4

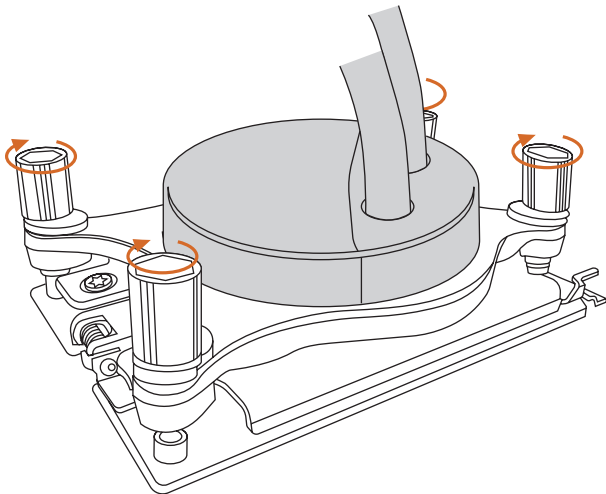

2.3 Installing Memory Modules (DIMM)

This motherboard provides four 288-pin DDR5 (Double Data Rate 5) DIMM slots, and supports Quad Channel Memory Technology.



1. For quad channel configuration, you always need to install identical (the same brand, speed, size and chip-type) DDR5 DIMM pairs.
2. It is not allowed to install a DDR, DDR2, DDR3 or DDR4 memory module into a DDR5 slot; otherwise, this motherboard and DIMM may be damaged.
3. If only two memory modules are installed in the DDR5 DIMM slots, then Dual Channel Memory Technology is activated. If three memory modules are installed, then Triple Channel Memory Technology is activated. If four memory modules are installed in the DDR5 DIMM slots, then Quad Channel Memory Technology is activated.
4. The DIMM only fits in one correct orientation. It will cause permanent damage to the motherboard and the DIMM if you force the DIMM into the slot at incorrect orientation.

Recommended Memory Configuration

1 DIMM

A0	C0	E0	G0
V			

2 DIMMs

A0	C0	E0	G0
V		V	

4 DIMMs

A0	C0	E0	G0
V	V	V	V

1

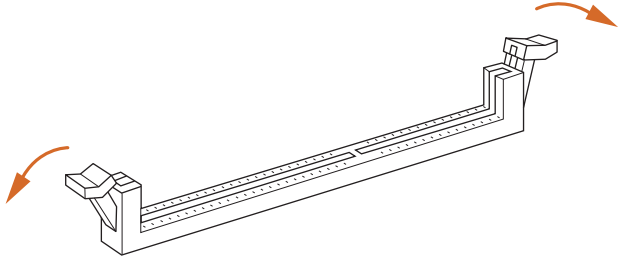

2

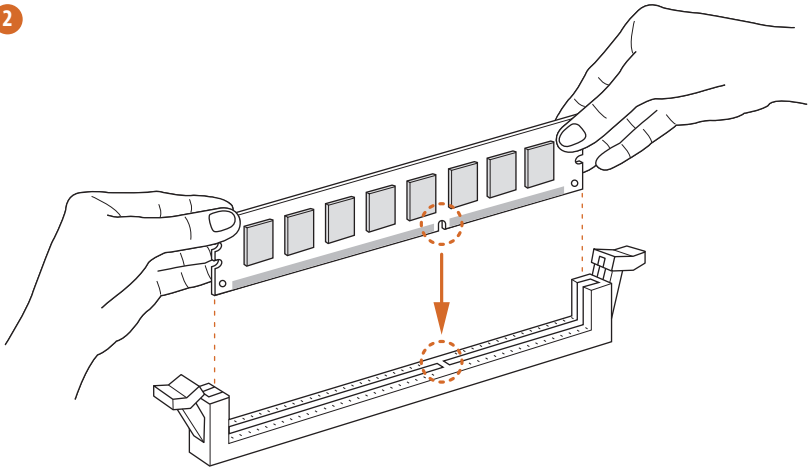

3

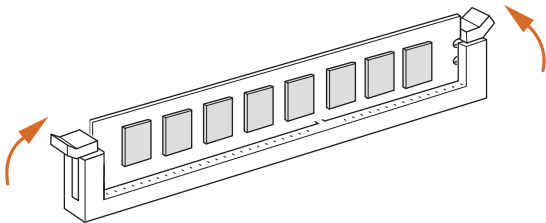

2.4 Connecting the Front Panel Header

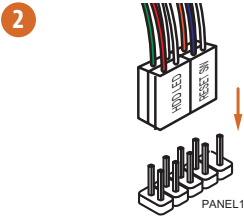
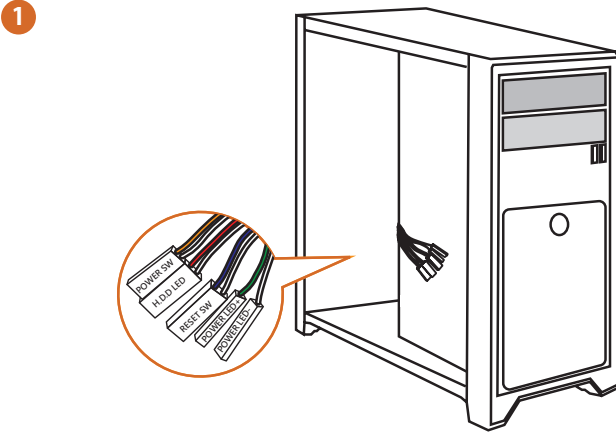

System Panel Header

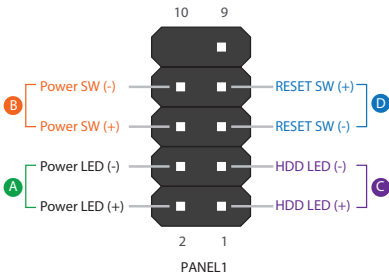

Front Panel Wires

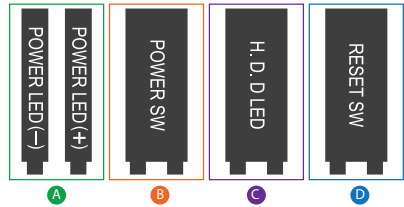

2.5 Installing the Motherboard

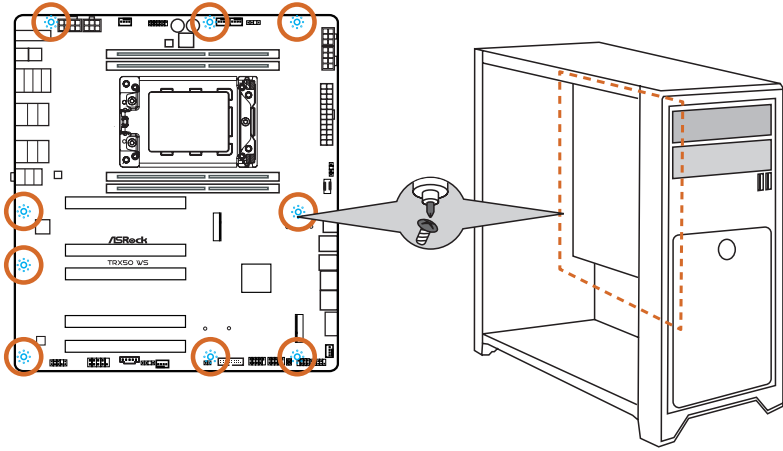

2.6 Installing SATA Drives

1

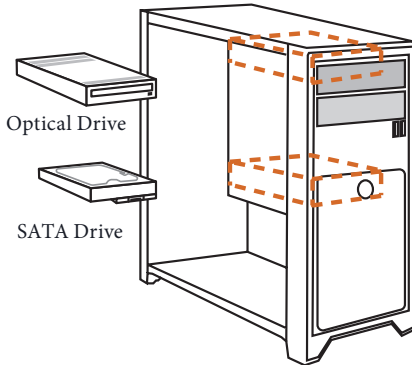

2

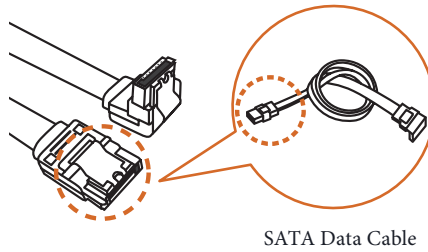

3

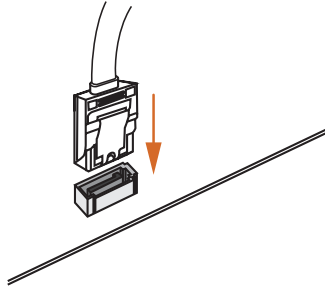

4

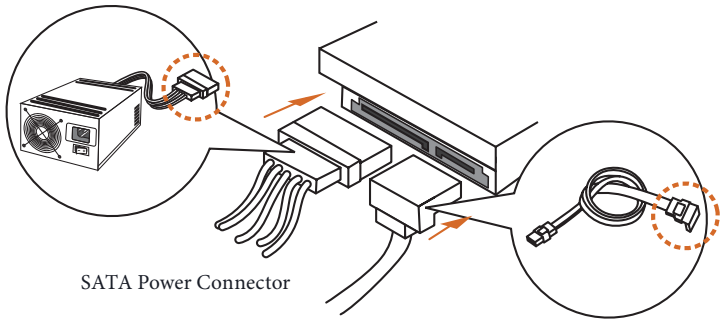

SATA Power Connector

SATA Data Connector

2.7 Installing a Graphics Card

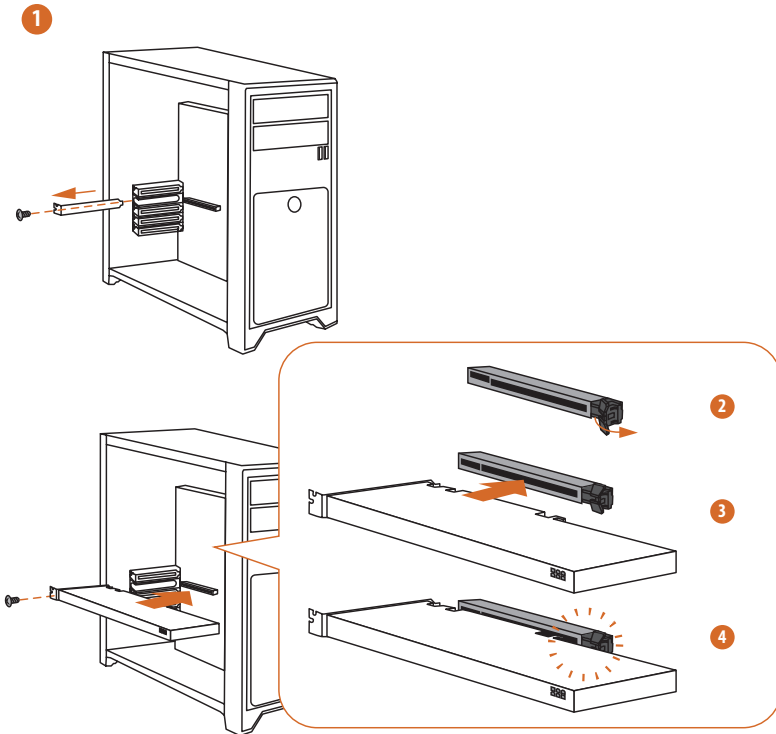

Expansion Slots (PCIe Slots)

There are 5 PCI Express slots on the motherboard.



Before installing an expansion card, please make sure that the power supply is switched off or the power cord is unplugged. Please read the documentation of the expansion card and make necessary hardware settings for the card before you start the installation.

PCIe slots:

PCIE1 (PCIe 5.0 x16 slot) is used for PCIe x16 lane width graphics cards.

PCIE2 (PCIe 4.0 x16 slot) is used for PCIe x4 lane width graphics cards.

PCIE3 (PCIe 5.0 x16 slot) is used for PCIe x16 lane width graphics cards.

PCIE4 (PCIe 5.0 x16 slot) is used for PCIe x8 lane width graphics cards.

PCIE5 (PCIe 4.0 x16 slot) is used for PCIe x8 lane width graphics cards.

*If you want to install a dual slot graphics card, install it to PCIE3.



For a better thermal environment, please connect a chassis fan to the motherboard's chassis fan connector (CHA_FAN1~3/WP) when using multiple graphics cards.

2.8 Connecting Peripheral Devices

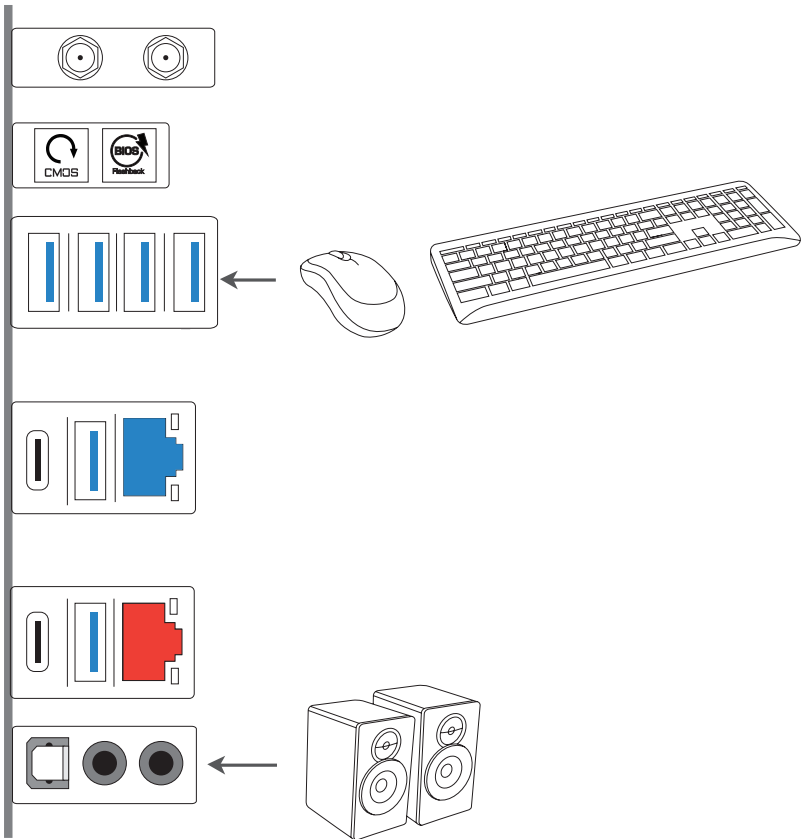

2.9 Connecting the Power Connectors

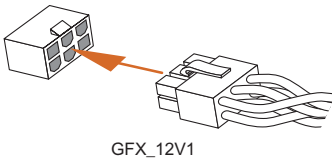
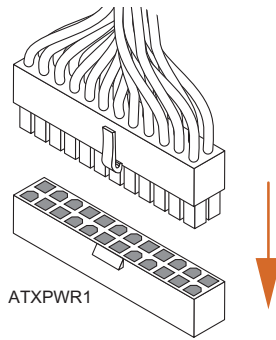
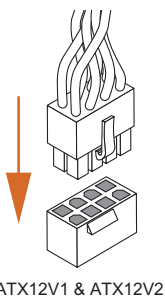
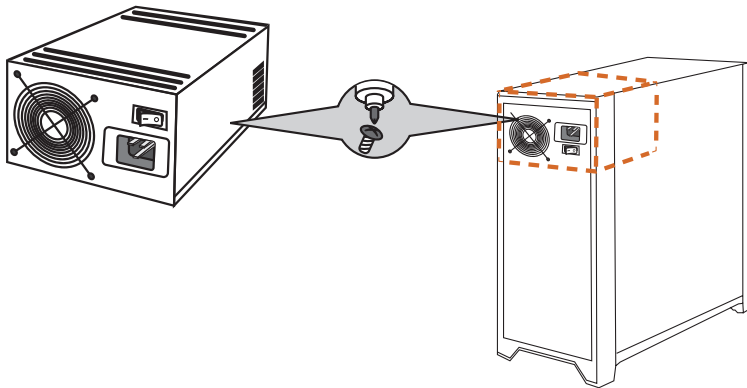

2.10 Power On

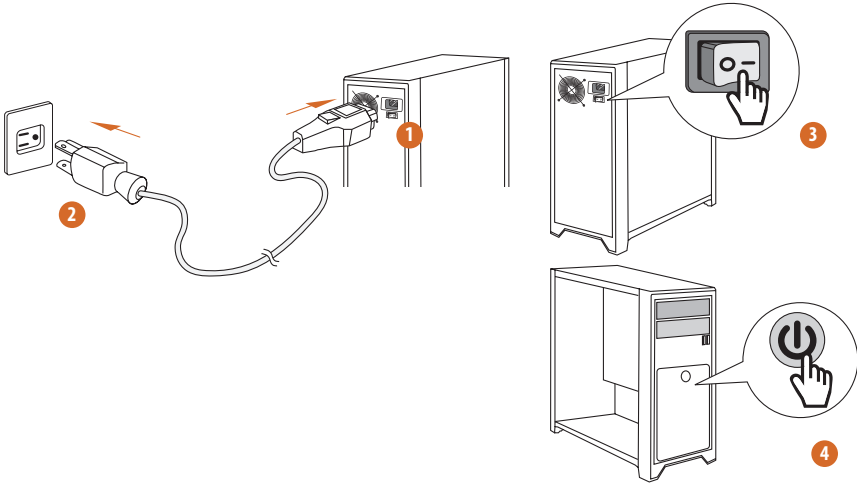

2.11 Jumpers Setup

The illustration shows how jumpers are setup. When the jumper cap is placed on the pins, the jumper is “Short”. If no jumper cap is placed on the pins, the jumper is “Open”.

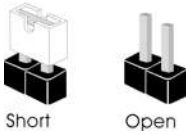

Clear CMOS Jumper
(CLRCMOS1) (see p.7, No. 31)

CLRCMOS1 allows you to clear the data in CMOS. The data in CMOS includes system setup information such as system password, date, time, and system setup parameters. To clear and reset the system parameters to default setup, please turn off the computer and unplug the power cord, then use a jumper cap to short the pins on CLRCMOS1 for 3 seconds. Please remember to remove the jumper cap after clearing the CMOS. If you need to clear the CMOS when you just finish updating the BIOS, you must boot up the system first, and then shut it down before you do the clear-CMOS action.

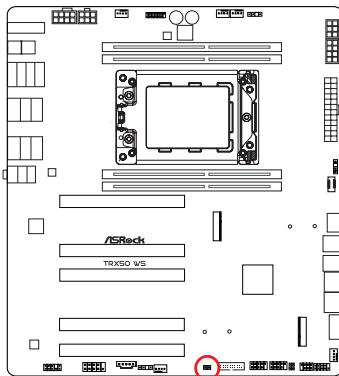

CLRCMOS1



2-pin Jumper

Short: Clear CMOS

Open: Default

2.12 Onboard Headers and Connectors



Onboard headers and connectors are NOT jumpers. Do NOT place jumper caps over these headers and connectors. Placing jumper caps over the headers and connectors will cause permanent damage to the motherboard.

System Panel Header

(9-pin PANEL1) (see p.7, No. 24)

Connect the power button, reset button and system status indicator on the chassis to this header according to the pin assignments below. Note the positive and negative pins before connecting the cables.

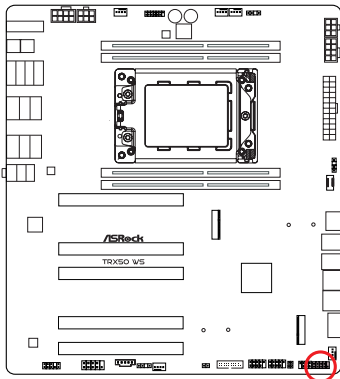

PANEL1

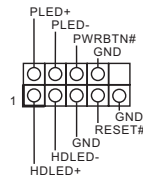

PWRBTN (Power Button):

Connect to the power button on the chassis front panel. You may configure the way to turn off your system using the power button.

RESET (Reset Button):

Connect to the reset button on the chassis front panel. Press the reset button to restart the computer if the computer freezes and fails to perform a normal restart.

PLED (System Power LED):

Connect to the power status indicator on the chassis front panel. The LED is on when the system is operating. The LED keeps blinking when the system is in S1/S3 sleep state. The LED is off when the system is in S4 sleep state or powered off (S5).

HDLED (Hard Drive Activity LED):

Connect to the hard drive activity LED on the chassis front panel. The LED is on when the hard drive is reading or writing data.

The front panel design may differ by chassis. A front panel module mainly consists of power button, power LED, hard drive activity LED, speaker and etc. When connecting your chassis front panel module to this header, make sure the wire assignments and the pin assignments are matched correctly.

Chassis Intrusion and Speaker Header

(7-pin SPK_CI1) (see p.7, No. 25)

Please connect the chassis intrusion and the chassis speaker to this header.

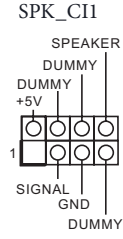
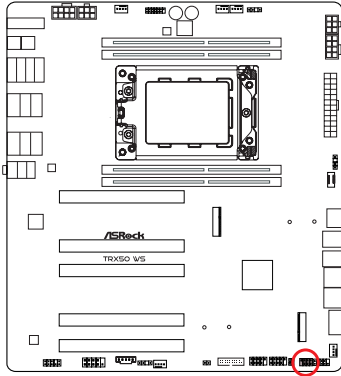

Serial ATA3 Connectors

Right Angle:

(SATA3_1) (see p.7, No. 20)(Lower)

(SATA3_2) (see p.7, No. 20)(Upper)

(SATA3_3) (see p.7, No. 21)(Lower)

(SATA3_4) (see p.7, No. 21)(Upper)

These four SATA3 connectors support SATA data cables for internal storage devices with up to 6.0 Gb/s data transfer rate.

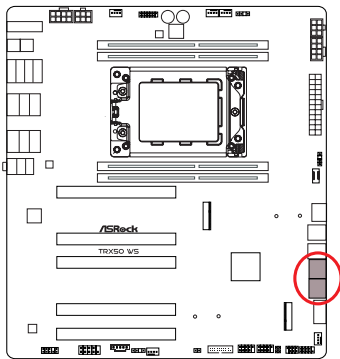

SATA3_4 SATA3_2
SATA3_3 SATA3_1

SlimSAS Connectors

Right Angle:

(SLIM1) (see p.7, No. 19)

(SLIM2) (see p.7, No. 18)

These connectors are used for the NVME PCIE or SATA devices.

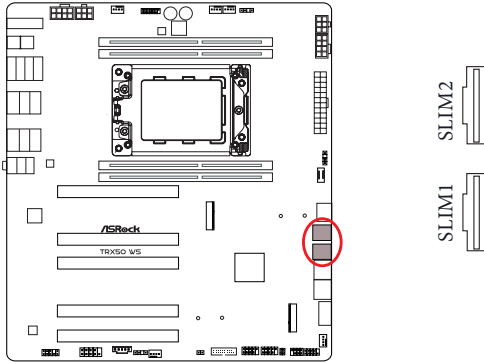

MCIO Connector

Right Angle:

(MCIO1) (see p.7, No. 17)

This connector is used for the PCIE device.

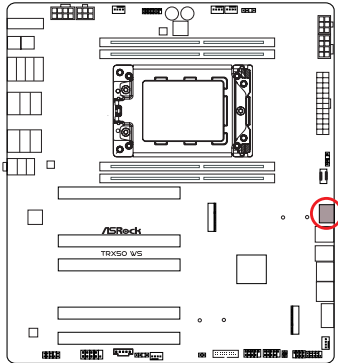

MCIO1



Pin	Definition	Pin	Definition
A1	GND	B1	GND
A2	G1_RXP3	B2	G1_TXP3
A3	G1_RXN3	B3	G1_TXN3
A4	GND	B4	GND
A5	G1_RXP2	B5	G1_TXP2
A6	G1_RXN2	B6	G1_TXN2
A7	GND	B7	GND
A8	BP_TYPE	B8	SCL
A9	WAKE#	B9	SDA
A10	GND	B10	GND
A11	CLKP	B11	BUF_RST0_L
A12	CLKN	B12	R_PRSNT_N
A13	GND	B13	GND
A14	G1_RXP1	B14	G1_TXP1
A15	G1_RXN1	B15	G1_TXN1
A16	GND	B16	GND
A17	G1_RXP0	B17	G1_TXP0
A18	G1_RXN0	B18	G1_TXN0
A19	GND	B19	GND

USB 2.0 Headers

(9-pin USB_1_2) (see p.7, No. 29)

(9-pin USB_3_4) (see p.7, No. 28)

There are two headers on this motherboard. Each USB 2.0 header can support two ports.

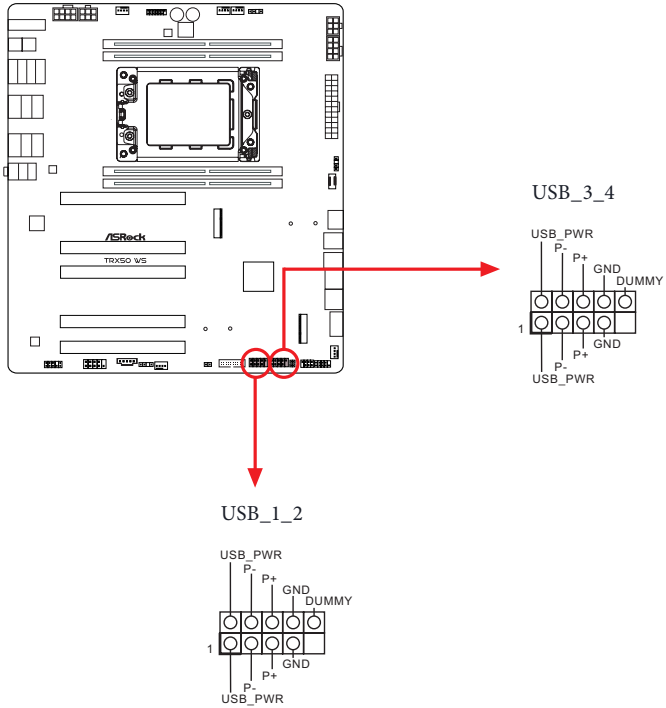

USB 3.2 Gen1 Header

(19-pin USB32_7_8) (see p.7, No. 30)

There is a header on this motherboard. This USB 3.2 Gen1 header can support two ports.

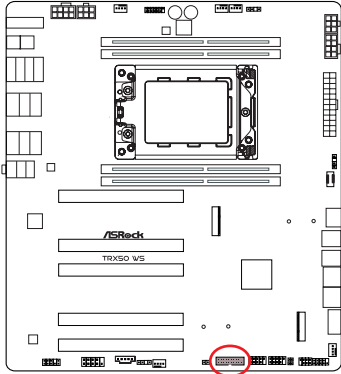

USB32_7_8

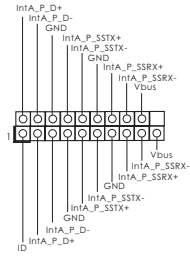

Front Panel Type C USB 3.2 Gen2 Header
(20-pin USB32_TC3) (see p.7, No. 16)

There is one Front Panel Type C USB 3.2 Gen2 Header on this motherboard. This header is used for connecting a USB 3.2 Gen2 module for additional USB 3.2 Gen2 ports.

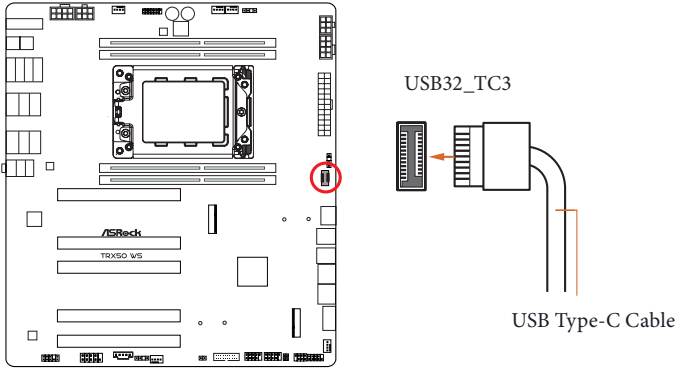

Front Panel Audio Header

Right Angle:

(9-pin HD_AUDIO1) (see p.7, No. 36)

This header is for connecting audio devices to the front audio panel.

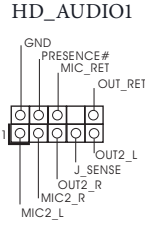
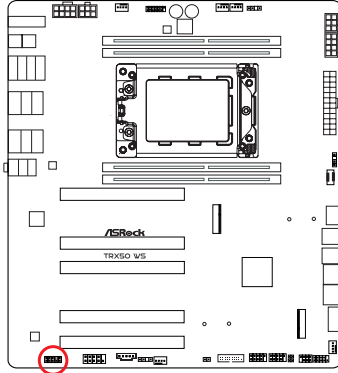

High Definition Audio supports Jack Sensing, but the panel wire on the chassis must support HDA to function correctly. Please follow the instructions in our manual and chassis manual to install your system.

Chassis/Water Pump Fan Connectors

(4-pin CHA_FAN1/WP) (see p.7, No. 32)

(4-pin CHA_FAN2/WP) (see p.7, No. 3)

(4-pin CHA_FAN3/WP) (see p.7, No. 23)

This motherboard provides three 4-Pin water cooling chassis fan connectors. If you plan to connect a 3-Pin chassis water cooler fan, please connect it to Pin 1-3.

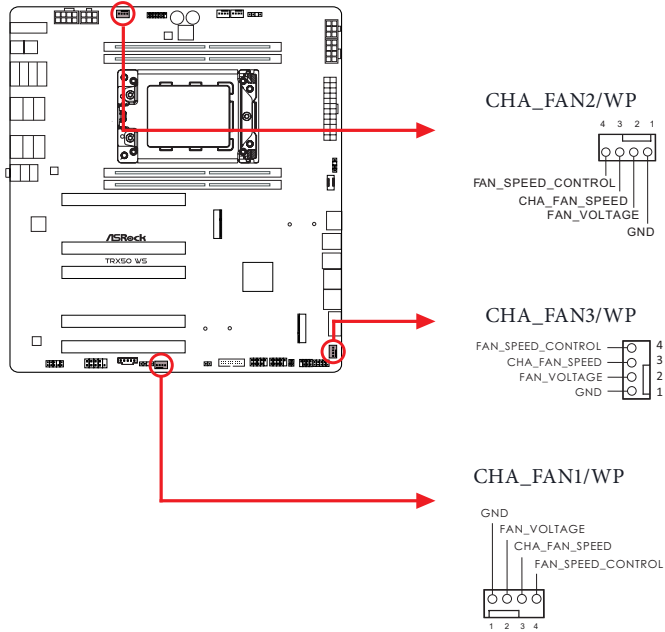

CPU Fan Connector

(4-pin CPU_FAN1) (see p.7, No. 8)

This motherboard provides a 4-Pin CPU fan (Quiet Fan) connector. If you plan to connect a 3-Pin CPU fan, please connect it to Pin 1-3.

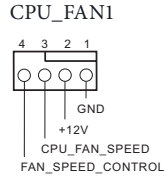
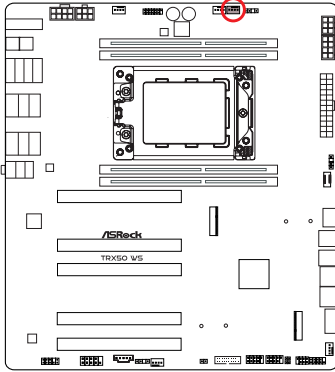

CPU/Water Pump Fan Connector

(4-pin CPU_FAN2/WP) (see p.7, No.7)

This motherboard provides a 4-Pin water cooling CPU fan connector. If you plan to connect a 3-Pin CPU water cooler fan, please connect it to Pin 1-3.

*The default of CPU_FAN2/WP BIOS setting is [Full Speed].

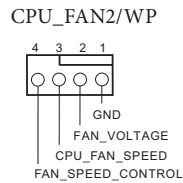
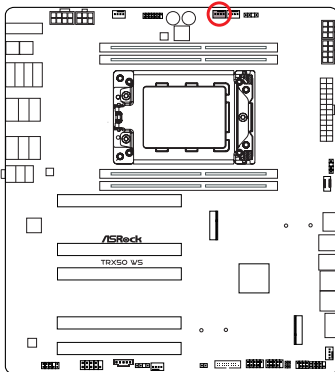

24 pin ATX Power Connector
(24-pin ATXPWR1) (see p.7, No. 13)

This motherboard provides a 24-pin ATX power connector. To use a 20-pin ATX power supply, please plug it along Pin 1 and Pin 13.

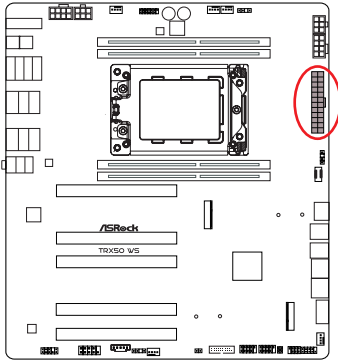

ATXPWR1

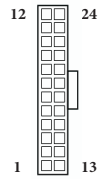

3 pin ATX Power Connector

(3-pin ATX_CON1) (see p.7, No. 14)

This motherboard provides a 3-pin ATX power connector. Plug the Multi PSU Adaptor Cable that comes with the package to this connector if you use a secondary PSU.

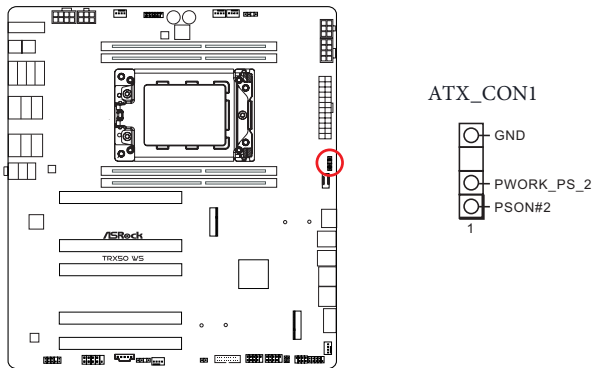

The following diagram illustrates how to connect the bundled Multi PSU Adaptor Cable.

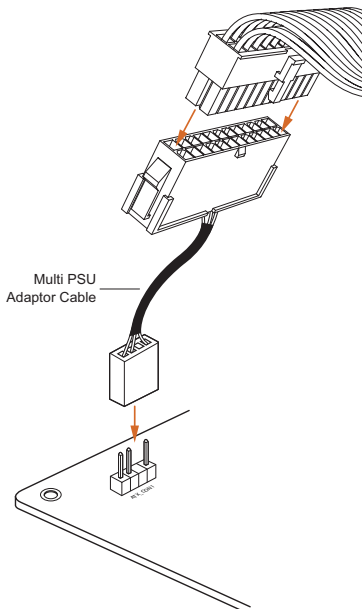

8 pin ATX 12V Power Connectors

(8-pin ATX12V1) (see p.7, No. 11)

(8-pin ATX12V2) (see p.7, No. 1)

This motherboard provides two 8-pin ATX 12V power connectors. To use a 4-pin ATX power supply, please plug it along Pin 1 and Pin 5.

* It is required to connect both ATX12V1 and ATX12V2; otherwise, the system may not boot up properly.

*It is required to connect all 8 pin and 6 pin 12V Power Connectors when over-clocking.

***Warning: Please make sure that the power cable connected is for the CPU and not the graphics card. Do not plug the PCIe 6-pin power cable to ATX12V1 or ATX12V2.**

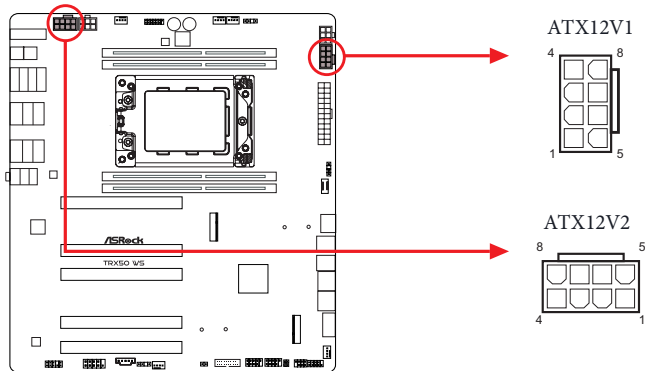

6-pin PCIe 12V Power Connectors
 (6-pin PCIe12V1_6P) (see p.7, No. 10)
 (6-pin PCIe12V2_6P) (see p.7, No. 2)

This motherboard provides two 6-pin PCIe 12V power connectors. Connect PCIe power cables to PCIe12V1_6P and PCIe12V2_6P.

*It is required to connect all 8 pin and 6 pin 12V Power Connectors when over-clocking.

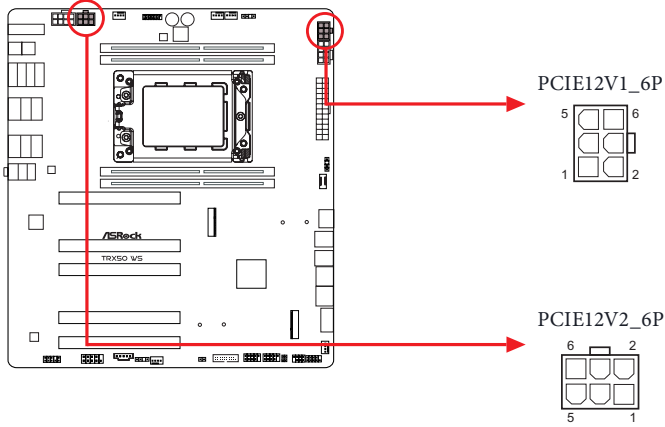

6 pin Graphics 12V Power Connector

Right Angle:

(6-pin GFX_12V1) (see p.7, No. 22)

This motherboard provides a 6 pin Graphics 12V Power Connector.

* It is required to connect a 6 pin PCIE 12V power cable to GFX_12V1; otherwise, the system may not boot up properly.

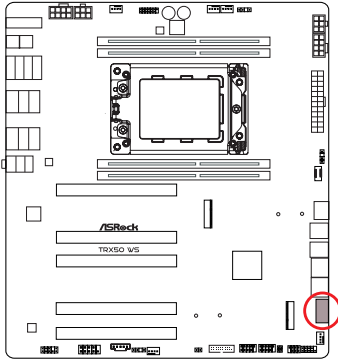

GFX_12V1



SPI TPM Header

(13-pin TPM_BIOS_PH1) (see p.7, No. 4)

This connector supports SPI Trusted Platform Module (TPM) system, which can securely store keys, digital certificates, passwords, and data. A TPM system also helps enhance network security, protects digital identities, and ensures platform integrity.

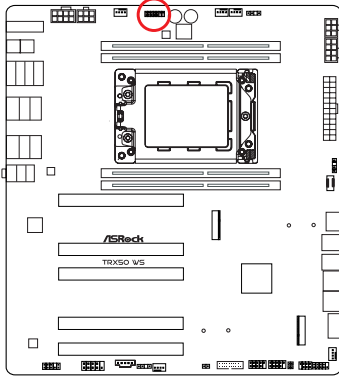

TPM_BIOS_PH1

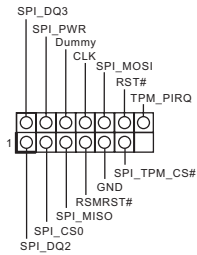

Thunderbolt AIC Connector

(5-pin TBI) (see p.7, No. 34)

Please connect a Thunderbolt™ add-in card (AIC) to the Thunderbolt AIC connector via the GPIO cable.

*Please install the Thunderbolt™ AIC card to PCIE2 or PCIE5 (default slot).

*For the Thunderbolt compatibility and limitation, please visit www.asrock.com.

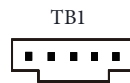
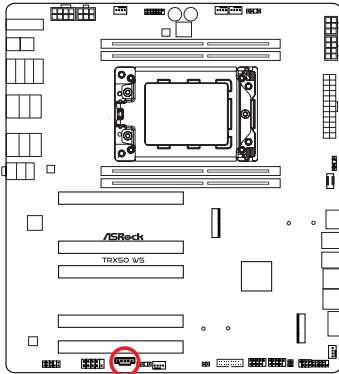

Serial Port Header

(9-pin COM1) (see p.7, No. 35)

This COM header supports serial port module.

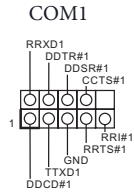
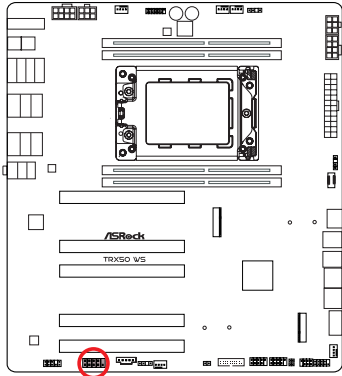

Thermistor Cable Headers

(2-pin T_SENSOR1) (see p.7, No. 26)

(2-pin T_SENSOR2) (see p.7, No. 27)

The Thermistor Cable Headers are used to connect thermistor cables to monitor the temperature of the critical components. Plug the thermistor cables that come with the package to these headers, and then attach the sensor ends to the components to detect their temperature.

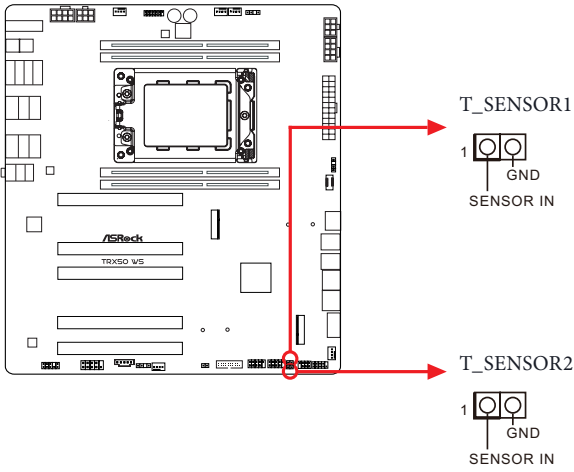

Connect your Thermistor Cables to the **Thermistor Cable Headers (T_SENSOR1 / T_SENSOR2)** on the motherboard.

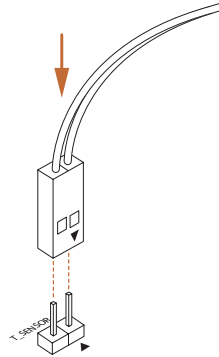

Addressable LED Headers

(3-pin ADDR_LED1) (see p.7, No. 33)

(3-pin ADDR_LED2) (see p.7, No. 9)

These headers are used to connect Addressable LED extension cables which allow users to choose from various LED lighting effects.

Caution: Never install the Addressable LED cable in the wrong orientation; otherwise, the cable may be damaged.

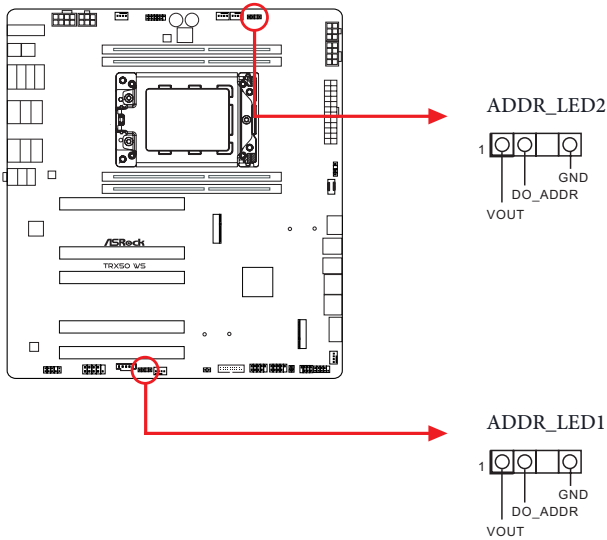

Connect your Addressable RGB LED strips to the **Addressable LED Headers (ADDR_LED1 / ADDR_LED2)** on the motherboard.

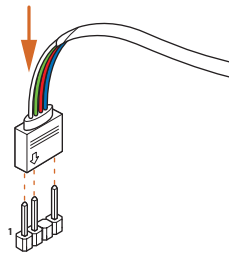

2.13 Smart Buttons

The motherboard has four smart buttons: Power Button, Reset Button, Clear CMOS Button and BIOS Flashback Button, allowing users to quickly turn on/off the system, reset the system, clear the CMOS values or flash the BIOS.

Power Button

(PWRBTN1) (see p.7, No. 6)

Power Button allows users to quickly turn on/off the system.

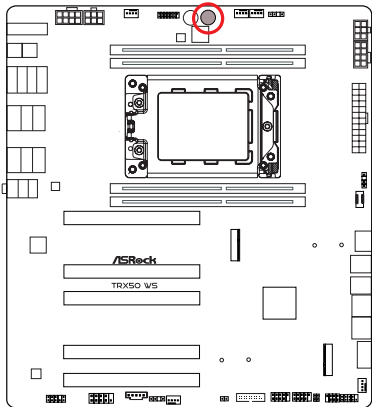

PWRBTN1



Reset Button

(RSTBTN1) (see p.7, No. 5)

Reset Button allows users to quickly reset the system.

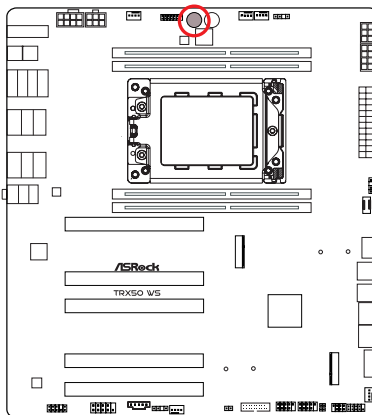

RSTBTN1



Clear CMOS Button

(CLR CMOS) (see p.10, No. 13)

Clear CMOS Button allows users to quickly clear the CMOS values.

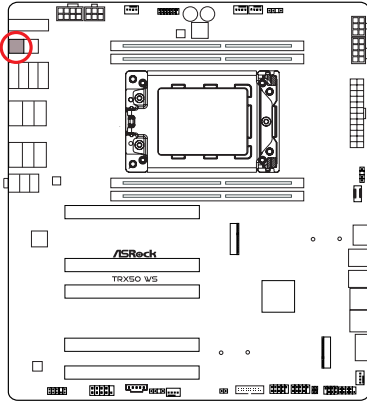

CLR CMOS



This function is workable only when you power off your computer and unplug the power supply.

BIOS Flashback Button

(BIOS_FB) (see p.10, No. 1)

BIOS Flashback Button allows users to flash the BIOS.

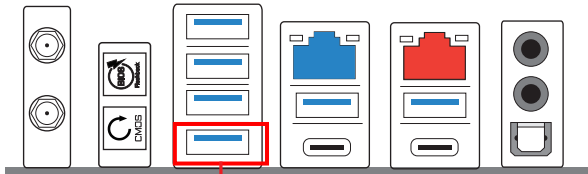
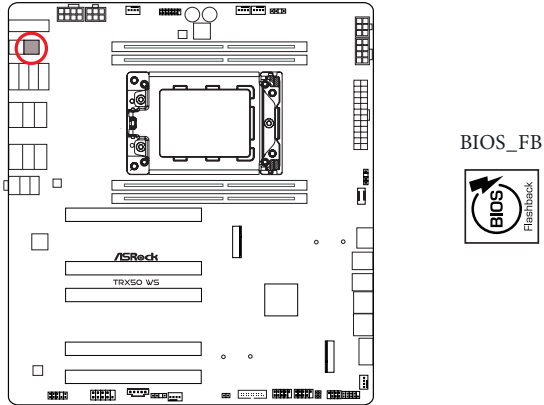

USB BIOS Flashback port

ASRock BIOS Flashback feature allows you to update BIOS without powering on the system, even without CPU.



Before using the BIOS Flashback function, please suspend BitLocker and any encryption or security relying on the TPM. Make sure that you have already stored and backup-ed the recovery key. If the recovery key is missing while encryption is active, the data will stay encrypted and the system will not boot into the operating system. It is recommended to disable fTPM before updating the BIOS. Otherwise an unpredictable failure may occur.

To use the USB BIOS Flashback function, Please follow the steps below.

1. Download the latest BIOS file from ASRock's website : <http://www.asrock.com>.
2. Copy the BIOS file to your USB flash drive. Please make sure the file system of your USB flash drive must be FAT32.
3. Extract BIOS file from the zip file.
4. Rename the file to "**creative.rom**" and save it to the root directory of X: USB flash drive.
5. Plug the 24 pin power connector to the motherboard. Then turn on the power supply's AC switch.
*There is no need to power on the system.
6. Then plug your USB drive to the USB BIOS Flashback port.
7. Press the BIOS Flashback Switch for about three seconds. Then the LED starts to blink.
8. Wait until the LED stops blinking, indicating that BIOS flashing has been completed.
*If the LED light turns solid green, this means that the BIOS Flashback is not operating properly. Please make sure that you plug the USB drive to the USB BIOS Flashback port.
**If the LED does not light up at all then please disconnect power from the system and remove/ disconnect the CMOS battery from the motherboard for several minutes. Reconnect power and battery and try again.

2.14 Dr. Debug

Dr. Debug is used to provide code information, which makes troubleshooting even easier. Please see the diagrams below for reading the Dr. Debug codes.

Code	Description
0x10	PEI_CORE_STARTED
0x11	PEI_CAR_CPU_INIT
0x15	PEI_CAR_NB_INIT
0x19	PEI_CAR_SB_INIT
0x31	PEI_MEMORY_INSTALLED
0x32	PEI_CPU_INIT
0x33	PEI_CPU_CACHE_INIT
0x34	PEI_CPU_AP_INIT
0x35	PEI_CPU_BSP_SELECT
0x36	PEI_CPU_SMM_INIT
0x37	PEI_MEM_NB_INIT
0x3B	PEI_MEM_SB_INIT
0x4F	PEI_DXE_IPL_STARTED
0x60	DXE_CORE_STARTED
0x61	DXE_NVRAM_INIT
0x62	DXE_SBRUN_INIT

0x63	DXE_CPU_INIT
0x68	DXE_NB_HB_INIT
0x69	DXE_NB_INIT
0x6A	DXE_NB_SMM_INIT
0x70	DXE_SB_INIT
0x71	DXE_SB_SMM_INIT
0x72	DXE_SB_DEVICES_INIT
0x78	DXE_ACPI_INIT
0x79	DXE_CSM_INIT
0x90	DXE_BDS_STARTED
0x91	DXE_BDS_CONNECT_DRIVERS
0x92	DXE_PCI_BUS_BEGIN
0x93	DXE_PCI_BUS_HPC_INIT
0x94	DXE_PCI_BUS_ENUM
0x95	DXE_PCI_BUS_REQUEST_RESOURCES
0x96	DXE_PCI_BUS_ASSIGN_RESOURCES
0x97	DXE_CON_OUT_CONNECT
0x98	DXE_CON_IN_CONNECT

0x99	DXE_SIO_INIT
0x9A	DXE_USB_BEGIN
0x9B	DXE_USB_RESET
0x9C	DXE_USB_DETECT
0x9D	DXE_USB_ENABLE
0xA0	DXE_IDE_BEGIN
0xA1	DXE_IDE_RESET
0xA2	DXE_IDE_DETECT
0xA3	DXE_IDE_ENABLE
0xA4	DXE_SCSI_BEGIN
0xA5	DXE_SCSI_RESET
0xA6	DXE_SCSI_DETECT
0xA7	DXE_SCSI_ENABLE
0xA8	DXE_SETUP_VERIFYING_PASSWORD
0xA9	DXE_SETUP_START
0xAB	DXE_SETUP_INPUT_WAIT
0xAD	DXE_READY_TO_BOOT
0xAE	DXE_LEGACY_BOOT

0xAF	DXE_EXIT_BOOT_SERVICES
0xB0	RT_SET_VIRTUAL_ADDRESS_MAP_BEGIN
0xB1	RT_SET_VIRTUAL_ADDRESS_MAP_END
0xB2	DXE_LEGACY_OPROM_INIT
0xB3	DXE_RESET_SYSTEM
0xB4	DXE_USB_HOTPLUG
0xB5	DXE_PCI_BUS_HOTPLUG
0xB6	DXE_NVRAM_CLEANUP
0xB7	DXE_CONFIGURATION_RESET
0xF0	PEI_RECOVERY_AUTO
0xF1	PEI_RECOVERY_USER
0xF2	PEI_RECOVERY_STARTED
0xF3	PEI_RECOVERY_CAPSULE_FOUND
0xF4	PEI_RECOVERY_CAPSULE_LOADED
0xE0	PEI_S3_STARTED
0xE1	PEI_S3_BOOT_SCRIPT
0xE2	PEI_S3_VIDEO_REPOST

0xE3	PEI_S3_OS_WAKE
0x50	PEI_MEMORY_INVALID_TYPE
0x53	PEI_MEMORY_NOT_DETECTED
0x55	PEI_MEMORY_NOT_INSTALLED
0x57	PEI_CPU_MISMATCH
0x58	PEI_CPU_SELF_TEST_FAILED
0x59	PEI_CPU_NO_MICROCODE
0x5A	PEI_CPU_ERROR
0x5B	PEI_RESET_NOT_AVAILABLE
0xD0	DXE_CPU_ERROR
0xD1	DXE_NB_ERROR
0xD2	DXE_SB_ERROR
0xD3	DXE_ARCH_PROTOCOL_NOT_AVAILABLE
0xD4	DXE_PCI_BUS_OUT_OF_RESOURCES
0xD5	DXE_LEGACY_OPROM_NO_SPACE
0xD6	DXE_NO_CON_OUT
0xD7	DXE_NO_CON_IN

0xD8	DXE_INVALID_PASSWORD
0xD9	DXE_BOOT_OPTION_LOAD_ERROR
0xDA	DXE_BOOT_OPTION_FAILED
0xDB	DXE_FLASH_UPDATE_FAILED
0xDC	DXE_RESET_NOT_AVAILABLE
0xE8	PEI_MEMORY_S3_RESUME_FAILED
0xE9	PEI_S3_RESUME_PPI_NOT_FOUND
0xEA	PEI_S3_BOOT_SCRIPT_ERROR
0xEB	PEI_S3_OS_WAKE_ERROR

2.15 M.2 SSD Card Installation Guide (M2_1)

The M.2 is a small size and versatile card edge connector that aims to replace mPCIe and mSATA. The Blazing M.2 Socket (M2_1, Key M) supports type 2260/2280 PCIe Gen5x4 mode.

Installing the M.2 SSD Card

Step 1

Prepare a M.2 SSD card.

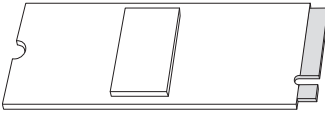

Step 2

Depending on the PCB type and length of your M.2 SSD card, find the corresponding nut location to be used.

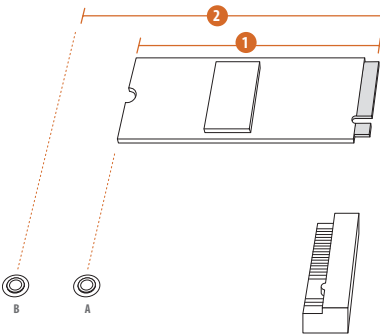

No.	1	2
Nut Location	A	B
PCB Length	6cm	8cm
Module Type	Type2260	Type 2280

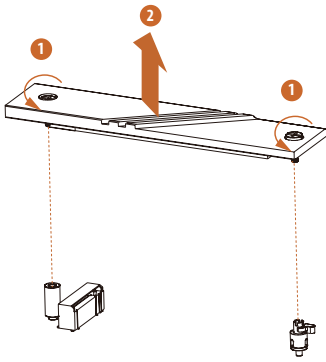

Step 3

Before installing a M.2 SSD card, please loosen the screws to remove the M.2 heatsink.

*Please remove the protective films on the bottom side of the M.2 heatsink before you install a M.2 SSD card.



Step 4

Peel off the yellow protective film on the nut A. Remove the lock nut on the nut B with a screwdriver, and tighten it into the nut A.

Skip Step 4 if your M.2 SSD card is Type 2280.

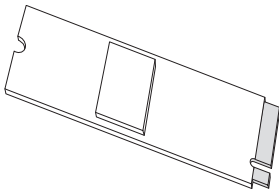

Step 5

Align and gently insert the M.2 SSD card into the M.2 slot. Please be aware that the M.2 SSD card only fits in one orientation.

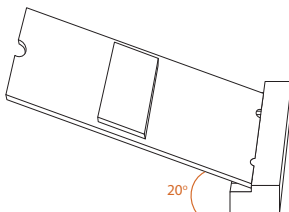

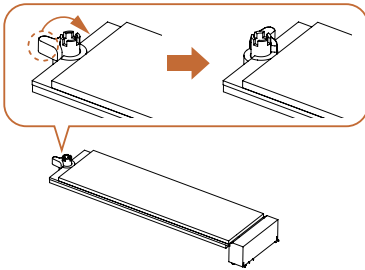

Step 6

Ensure that the notch at the end of the M.2 SSD card aligns with the nut. Then secure the M.2 SSD card by turning the nut lock clockwise to its locked position.

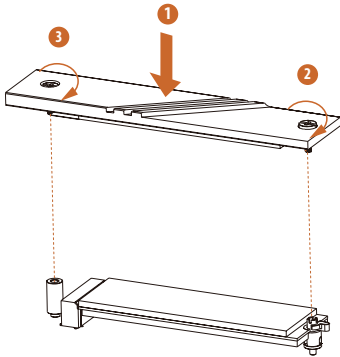

Step 7

Tighten the screw with a screwdriver to secure the M.2 heatsink into place. Please do not overtighten the screw as this might damage the M.2 heatsink.

For the latest updates of M.2 SSD card support list, please visit our website for details:
<http://www.asrock.com>

2.16 M.2 SSD Card Installation Guide (M2_2)

The M.2 is a small size and versatile card edge connector that aims to replace mPCIe and mSATA. The Hyper M.2 Socket (M2_2, Key M) supports type 2260/2280 PCIe Gen4x4 mode.

Installing the M.2 SSD Card

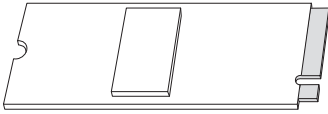

Step 1

Prepare a M.2 SSD card.

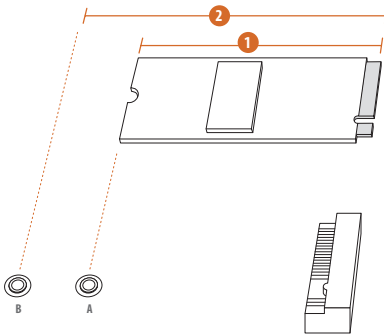

Step 2

Depending on the PCB type and length of your M.2 SSD card, find the corresponding nut location to be used.

No.	1	2
Nut Location	A	B
PCB Length	6cm	8cm
Module Type	Type2260	Type 2280

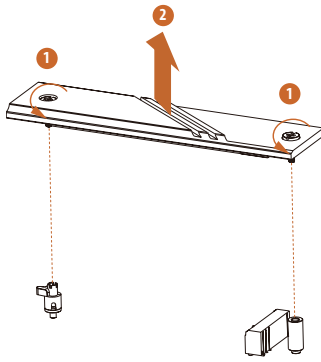

Step 3

Before installing a M.2 SSD card, please loosen the screws to remove the M.2 heatsink.

*Please remove the protective films on the bottom side of the M.2 heatsink before you install a M.2 SSD card.



Step 4

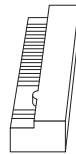

Peel off the yellow protective film on the nut A. Remove the lock nut on the nut B with a screwdriver, and tighten it into the nut A.

Skip Step 4 if your M.2 SSD card is Type 2280.

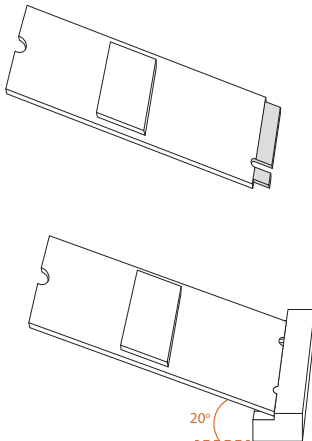

Step 5

Align and gently insert the M.2 SSD card into the M.2 slot. Please be aware that the M.2 SSD card only fits in one orientation.

Step 6

Ensure that the notch at the end of the M.2 SSD card aligns with the nut. Then secure the M.2 SSD card by turning the nut lock clockwise to its locked position.

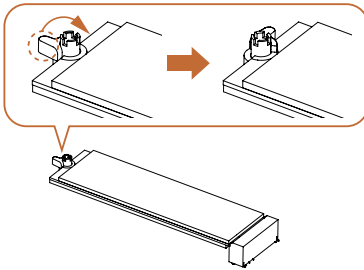
**Step 7**

Tighten the screw with a screwdriver to secure the M.2 heatsink into place. Please do not overtighten the screw as this might damage the M.2 heatsink.

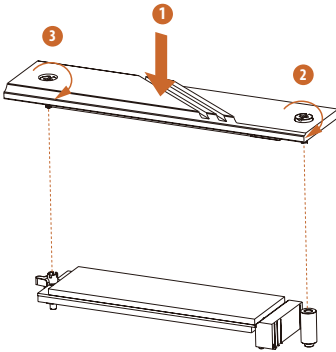

For the latest updates of M.2 SSD card support list, please visit our website for details:
<http://www.asrock.com>

The terms HDMI® and HDMI High-Definition Multimedia Interface, and the HDMI logo are trademarks or registered trademarks of HDMI Licensing LLC in the United States and other countries.



WARNING

THIS PRODUCT CONTAINS A BUTTOON BATTERY

If swallowed, a button battery can cause serious injury or death.

Please keep batteries out of sight or reach of children.

CALIFORNIA, USA ONLY

The Lithium battery adopted on this motherboard contains Perchlorate, a toxic substance controlled in Perchlorate Best Management Practices (BMP) regulations passed by the California Legislature. When you discard the Lithium battery in California, USA, please follow the related regulations in advance.

“Perchlorate Material-special handling may apply, see www.dtsc.ca.gov/hazardouswaste/perchlorate”

AUSTRALIA ONLY

Our goods come with guarantees that cannot be excluded under the Australian Consumer Law. You are entitled to a replacement or refund for a major failure and compensation for any other reasonably foreseeable loss or damage caused by our goods. You are also entitled to have the goods repaired or replaced if the goods fail to be of acceptable quality and the failure does not amount to a major failure. If you require assistance please call ASRock Tel : +886-2-28965588 ext.123 (Standard International call charges apply)



ASRock INC. hereby declares that this device is in compliance with the essential requirements and other relevant provisions of related UKCA Directives. Full text of UKCA declaration of conformity is available at: <http://www.asrock.com>



ASRock INC. hereby declares that this device is in compliance with the essential requirements and other relevant provisions of related Directives. Full text of EU declaration of conformity is available at: <http://www.asrock.com>

ASRock follows the green design concept to design and manufacture our products, and makes sure that each stage of the product life cycle of ASRock product is in line with global environmental regulations. In addition, ASRock disclose the relevant information based on regulation requirements.

Please refer to <https://www.asrock.com/general/about.asp?cat=Responsibility> for information disclosure based on regulation requirements ASRock is complied with.



DO NOT throw the motherboard in municipal waste. This product has been designed to enable proper reuse of parts and recycling. This symbol of the crossed out wheeled bin indicates that the product (electrical and electronic equipment) should not be placed in municipal waste. Check local regulations for disposal of electronic products.

CE Warning

This device complies with directive 2014/53/EU issued by the Commission of the European Community.

This equipment complies with EU radiation exposure limits set forth for an uncontrolled environment.

This equipment should be installed and operated with minimum distance 20cm between the radiator & your body.

Operations in the 5.15-5.35/6GHz band are restricted to indoor usage only.

	AT	BE	BG	CH	CY	CZ	DE
	DK	EE	EL	ES	FI	FR	HR
	HU	IE	IS	IT	LI	LT	LU
	LV	MT	NL	NO	PL	PT	RO
	SE	SI	SK	TR			



Radio transmit power per transceiver type

Function	Frequency	Maximum Output Power (EIRP)
WiFi	2400-2483.5 MHz	18.5 + / -1.5 dbm
	5150-5250 MHz	21.5 + / -1.5 dbm
	5250-5350 MHz	18.5 + / -1.5 dbm (no TPC)
		21.5 + / -1.5 dbm (TPC)
	5470-5725 MHz	25.5 + / -1.5 dbm (no TPC) 28.5 + / -1.5 dbm (TPC)
Bluetooth	5725-5850 MHz	11 + / -1.5 dbm
	5945-6425 MHz	21 + / -1.5 dbm
	2400-2483.5 MHz	8.5 + / -1.5 dbm

ASRock Incorporation

Contains Wi-Fi 6E module with Bluetooth

AMD® Wi-Fi 6E RZ608

Model: MT7921K

FCC ID: RAS-MT7921K

IC: 7542A-MT7921K



5.15~5.35GHz indoor use only



ASRock Incorporation

Contains Wi-Fi 6E module with Bluetooth

AMD® Wi-Fi 6E RZ616

Model: MT7922A22M

FCC ID: RAS-MT7922A22M

IC: 7542A-MT7922A22M

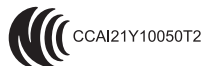
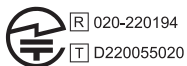

5.15~5.35/6GHz indoor use only



ASRock Incorporation

Contains Wi-Fi 7 module with Bluetooth

AMD® Wi-Fi 7 RZ717

Model: MT7925B22M

FCC ID: RAS-MT7925B22M



IC: 7542A-MT7925B22M

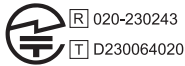

020-230243

D230064020



CCAI23Y10100T7

5GHz band(W52,W53)&6GHz(LPI):indoor use only