

MS-Terminator B760M D5

MAXSUN Motherboard Quick Guide



Dear Customer

Thank you for purchasing and choosing MAXSUN products. If you have any questions or need assistance while using the MAXSUN motherboard, please feel free to contact your local MAXSUN product distributor, or call the customer service hotline for mainland China users at 400-696-0606 to enjoy our after-sales support.

SK Group adheres to the relevant responsibility regulations of the national quality supervision and inspection "three guarantees" service, and provides you with a three-year quality assurance commitment of premium service. Please refer to the attached document for specific service terms. Thank you!

One : Three year warranty service

During the first to third year after purchase, if any quality issues listed in the "Microcomputer Product Performance Failure Table" occur while using the product normally, and if they fall within the scope of normal warranty, the final seller shall provide you with corresponding services in accordance with the relevant regulations on the "Three Guarantees".

If any components of the product are discontinued and equivalent replacements cannot be found on the market, the merchant will negotiate with you to jointly depreciate and supplement the price difference for other products (defective products will be depreciated according to the proportion stipulated in the "Three Guarantees").

Two : The situations not covered by warranty services

1. The motherboard has no faults;
2. The motherboard is beyond the warranty period;
3. The motherboard has incurred physical damage due to improper use, such as missing components or plugins, PCB deformation, severe scratches or oxidation, or major component burnout;
4. The barcode of the motherboard has been altered, lost, moved, or damaged;
5. The motherboard has been damaged due to human negligence, misuse, or irresistible forces, such as immersion in water, fire, lightning strikes, or other mechanical damages, as well as damage caused by not following the instructions;
6. The motherboard has been damaged due to improper packaging or handling during the process of sending it for repair;
7. The motherboard cannot be restored due to attempts by you or a third party to disassemble, repair, or replace components or devices (such as heat sinks).

Notice :

Copyright © 2024 MAXSUN COMPUTER INC. All Rights Reserved.

No part of this manual, including the products and software described in it, may be reproduced, transmitted, transcribed, stored in a retrieval system, or translated into any language in any form or by any means, except documentation kept by the purchaser for backup purposes, without the express written permission of MAXSUN COMPUTER INC.

Copyright Statement:

The copyright of this manual belongs to MAXSUN Technology Motherboard (referred to as MAXSUN Motherboard). MAXSUN Motherboard has the right to add or delete content without knowing the user. This manual is a purely technical document and does not imply or reflect any third-party content, and is not responsible for any ambiguities caused by printing and typesetting errors. Any third-party registered trademarks mentioned in this manual are owned by their manufacturers or brand suppliers.

Copyright © 2024 MAXSUN COMPUTER INC. All Rights Reserved.

About Manual:

This manual can be used as a technical reference. When using it, please refer to the actual product.

Abnormal Warranty Coverage:

1. Product failure and damage caused by improper use and installation, dismantling or replacing parts by yourself, or arbitrary changes in specifications are not covered by the warranty.
2. Once the product is changed or modified, as well as any damage caused by indirect, special or unexpected circumstances, it is not covered by the warranty.

Avoid using this product in the following environments: high temperature, low air pressure, low temperature, moisture, dust, strong magnetic field and long-term exposure to sunlight.

Our company recommends that you use it in an environment with an altitude of less than 3,000 meters, a temperature of 0° to 35°C, and a humidity of 5% to 95%.

FCC Rules:

This device complies fully with Part 15 of the FCC Rules. Work in compliance with the following two conditions:

1. This device will not cause personal injury;
2. The device must be able to accept any resolved conflict interference, including conflicts that may cause improper operation.

Notice:

This device has been tested and found to comply with the limits for a Class B digital device, pursuant to Part 15 of the FCC Rules. This restriction is a reasonable precaution against the possibility of harmful collisions during installation. This device generates, uses, and can radiate radio frequency energy and, if not installed and used in accordance with the manufacturer's instructions, may cause harmful interference with communications tools. However, there is no guarantee that no conflicts will arise under a particular installation.

If, after turning the device off and on again, it is still determined that the device is actually causing a conflict with the radio or television, the user is asked to use one or more of the following knowledge to correct the conflict:

1. **Reinstall the receiving antenna;**
2. **Increase the separation between the device and the receiver;**
3. **Plug the computer into different sockets so that the two devices use different circuits;**
4. **If necessary, users can contact dealers or more experienced technical engineers to obtain additional information.**

To comply with emission restrictions, always use protective interface cables. The user may not make any changes or modifications to this device without express consent.

Security Information:

The components contained in this package have the potential to be damaged by electrostatic discharge (ESD). Please observe the following precautions to ensure successful computer assembly.

- Make sure all components are connected securely. If the connection is not tight, the computer may not recognize the component or be unable to turn on.
- When picking up the motherboard, please hold it by its edges to avoid touching sensitive components of the motherboard.
- It is recommended to wear an electrostatic discharge (ESD) wrist strap when handling the motherboard to prevent static electricity from damaging its configuration. If the ESD wrist strap does not work, discharge yourself by touching another metal object before handling the motherboard.
- When the motherboard is not installed, place the motherboard on an electrostatic shielding container or anti-static mat.
- Before turning on your computer, make sure there are no loose screws or metal components on the motherboard or anywhere inside the computer case.
- Do not start the computer until the installation is complete. Failure to do so may result in permanent damage to the component and injury to the user.
- If you need assistance during any installation step, please consult a professional computer technician.
- Before installing or removing any computer components, turn off the power and unplug the power cord from the outlet.
- Keep this user guide for future reference.
- This motherboard must be kept away from moisture.
- Before connecting the power supply to an electrical outlet, make sure that your outlet provides the same indicated voltage rated on the power supply.
- Place the power cord where it will not be walked on, and do not place anything on the power cord.
- Pay attention to all warning signs on the motherboard.
- When any of the following conditions occurs, please submit this motherboard to maintenance personnel for inspection:
 - I. Liquid has penetrated into the computer. Liquid has penetrated into the computer.
 - II. The motherboard is exposed to moisture.
 - III. The motherboard is not working, or you still cannot make the motherboard work after following the user guide.
 - IV. The motherboard has been dropped and damaged.
 - V. The motherboard has obvious signs of damage.
- Never place the motherboard in an environment above 60 degrees Celsius (140 degrees Fahrenheit) to avoid damage to the motherboard.

Quick Guide:

Thank you for purchasing and using MAXSUN products. The following will introduce you to the common interfaces on motherboard products and how to install and use them. Before officially starting, please make sure you have the following components and tools ready:

- Intel® LGA1700 CPU
- Intel® LGA1700 600/700 Series Motherboard
- LGA1700 CPU Cooler & Thermal Grease
- DDR4 / DDR5 memory
- M.2 HDD / SATA HDD
- PCIe x16 graphics card (if the CPU comes with its own core graphics card, it can be omitted)
- Computer case
- Screws & screwdrivers needed to install the computer (the screws used to assemble a desktop computer are generally 'M3' & '#6' specifications)



Installation Instructions

• Intel® LGA1700 Processor Installation

Only supports Intel® LGA1700 14th/13th/12th generation Core™, Pentium® Gold and Celeron® processors

This slot has a fool-proof function. When installing the processor, pay attention to the fool-proof slot to avoid damaging the processor and processor socket.

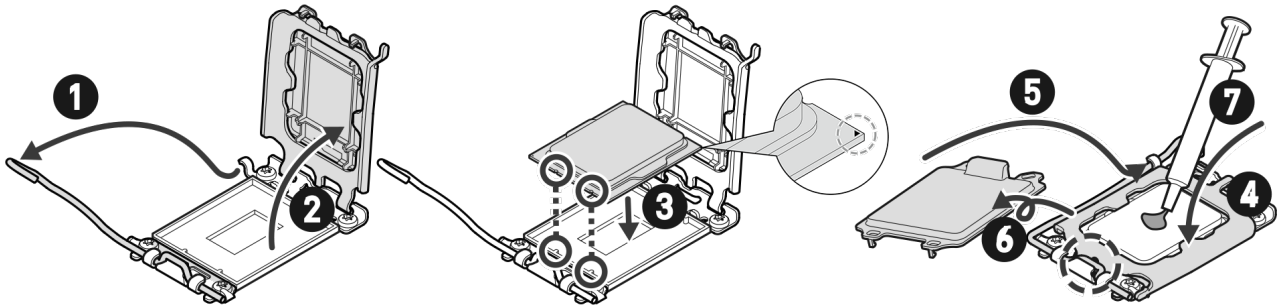

• LGA1700 CPU Cooler Installation

Only LGA 1700 hole pitch radiators are supported. Do not use other empty radiators for forced installation, such as LGA 1200, to avoid unnecessary damage and failure.

After installing the radiator, be sure to connect the 4-Pin fan power connector to prevent the fan from not working properly and causing overheating and damage to the CPU.

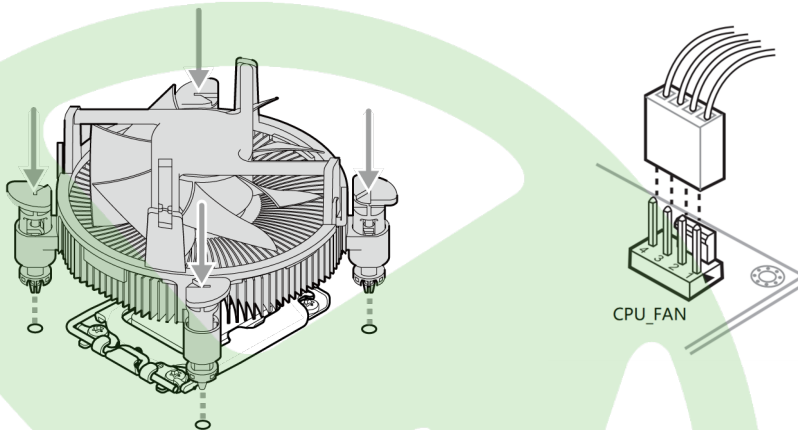

• DDR4 / DDR5 U_DIMM RAM Installation

Only U_DIMM memory insertion and use is supported. DDR4 memory supports 2400MHz by default, and DDR5 memory supports 4800MHz by default.

B series and Z series motherboards support memory overclocking in the BIOS, and the memory slots have an anti-misinsertion function. Do not insert or remove them violently.

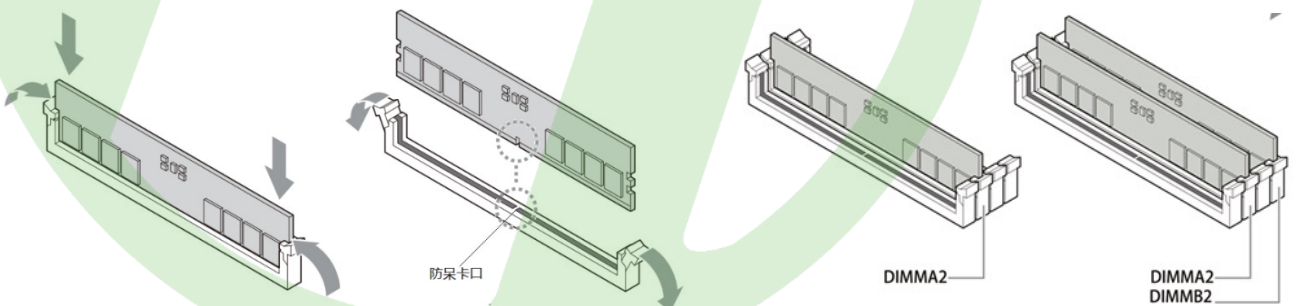

Installation Instructions

• 24-Pin ATX Power Connector Installation

Used to connect the 12V, 5V, 3.3V power supplies required by the 24-Pin of the motherboard. The slot has an anti-misinsertion function.

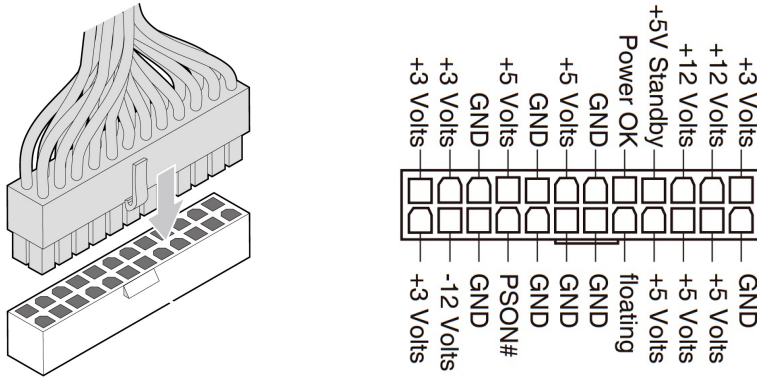

• CPU 8-Pin 12V Power Connector Installation

Used to connect the motherboard CPU +12V power supply. The interface has the function of preventing wrong insertion. If the CPU +12V power supply interface on the motherboard is (8+8)-Pin, be sure to insert the complete (8+4)-Pin interface to prevent unnecessary hardware damage caused by wire overheating.

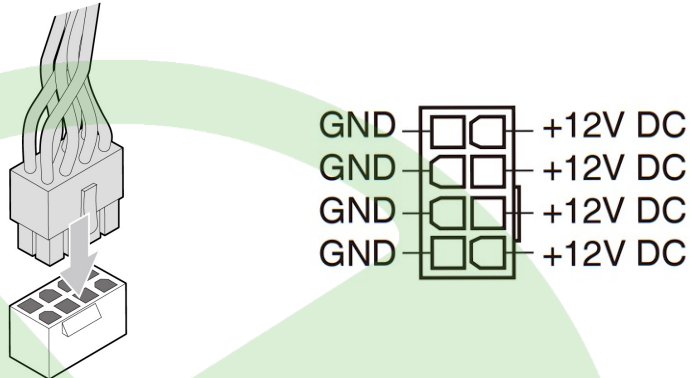

• CPU 4-Pin 12V Power Connector Installation

Used to connect the motherboard CPU +12V power supply. The interface has the function of preventing wrong insertion. If the CPU +12V power supply interface on the motherboard is (8+4)-Pin, be sure to insert the complete (8+4)-Pin interface to prevent unnecessary hardware damage caused by wire overheating.

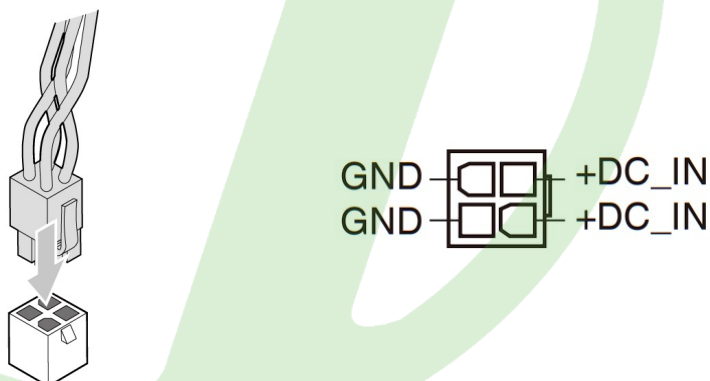

Installation Instructions

- **PCIe X16 Slot Installation**

For installation of full-length PCIe X16 devices, recommended for installation of discrete graphics cards

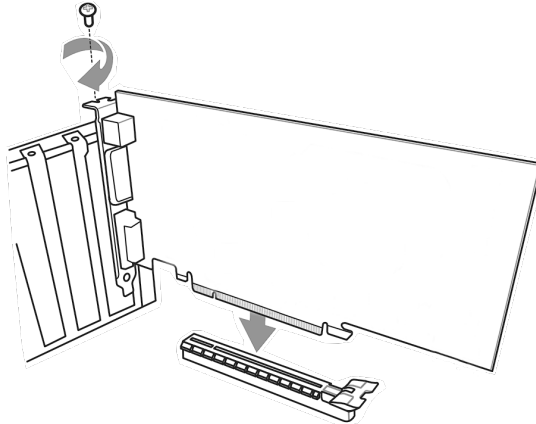

- **PCIe X14 Slot Installation**

For installation of full-length PCIe X4 devices

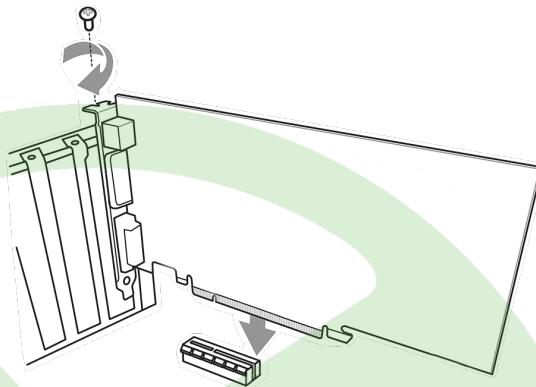

- **PCIe X1 Slot Installation**

For installation of full-length PCIe X4 devices

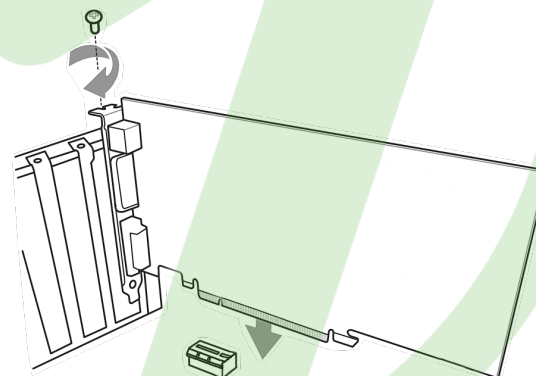

Installation Instructions

- **M.2 (Key_M) Slot Installation**

This location is used to install M.2 SSD. Different types will have different length compatibility. Maximum support is 22110. When installing, please pay attention to tightening the fixing screws as shown below to prevent SSD damage or data loss due to poor contact during use.

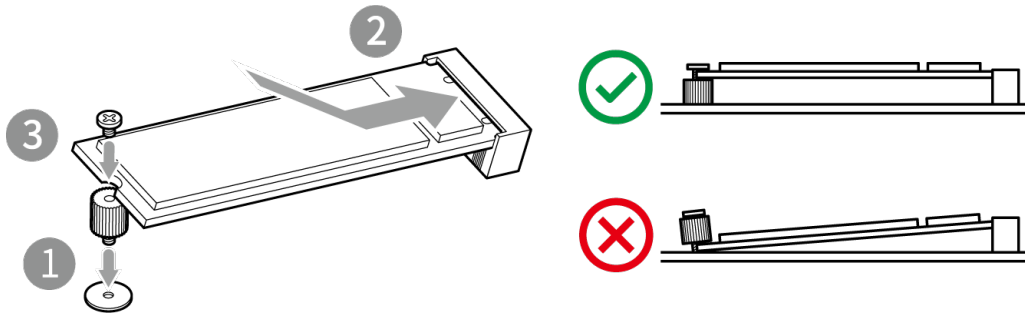

- **4-Pin PUMP PIN Installation**

Used to connect the water-cooling water pump of the CPU water-cooling radiator to supply power to the radiator. Be sure to connect it, otherwise the hardware may be damaged because the CPU heat cannot be discharged. The interface is designed to prevent misplugging, and the interface supports PWM mode.

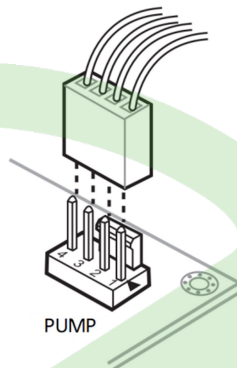

- **4-Pin Chassis Fan PIN Installation**

Used to connect a 4-Pin cooling fan. Please be sure to connect it, otherwise the hardware may be damaged because the heat in the chassis cannot be discharged. The interface is designed to prevent misplugging. The interface supports PWM mode.

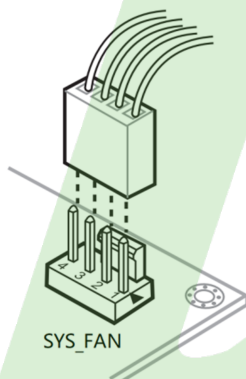

Installation Instructions

• USB Type-C® Front PIN Installation

Used to connect Type-C ® Module, expandable chassis front Type-C ® Interface and Post Type-C ® Expand the interface.

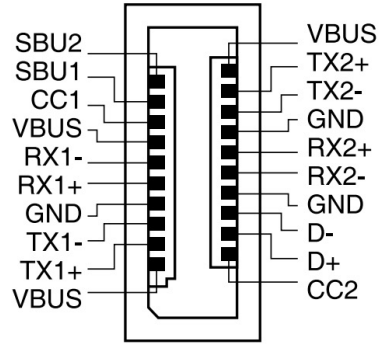

• USB 3.2 Gen1 Front Pin (19-Pin) Installation

Used to connect the USB 3.2 module, a set of pins can expand to 2* USB 3.2 Gen1 interfaces on the front of the chassis. The interface protocol is USB 3.2 Gen 1, with a data transfer rate of up to 5Gb/s.

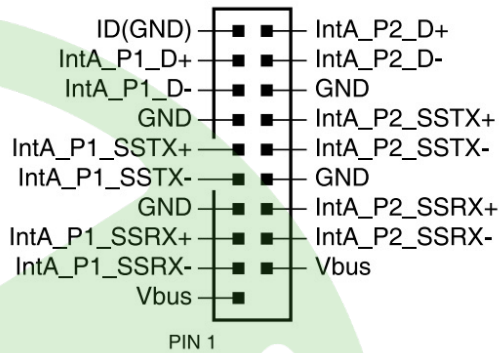
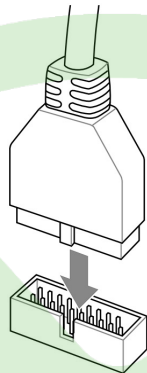

• USB 2.0 Front Pin (9-Pin) Installation

Used to connect USB 2.0 modules, a set of pins can expand 2* USB 2.0 Gen1 interfaces on the front of the chassis. The interface protocol is USB 2.0, with a maximum data transfer rate of 480Mb/s.

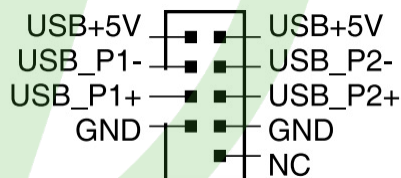
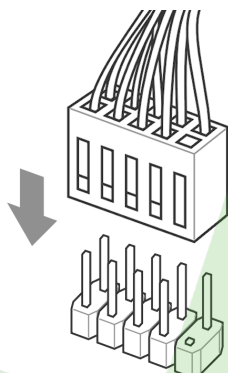

Installation Instructions

• 3-PIN ARGB PIN Installation

Used to connect 3-Pin ARGB lighting devices, the lighting effect is off by default. It supports lighting effect control in BIOS and MAXSUN SYNC lighting effect software control in the system. Please note that this pin is not compatible with 4-Pin RGB devices, and incorrect insertion may cause device damage!

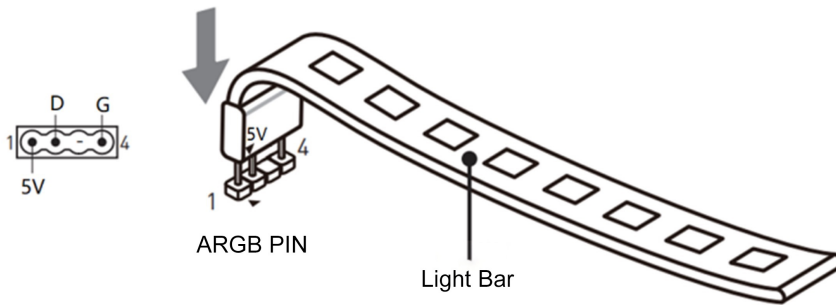

• 4-Pin RGB PIN Installation

Used to connect 4-Pin NRGB lighting devices, the lighting effect is off by default. It supports lighting effect control in BIOS and MAXSUN SYNC lighting effect software control in the system. Please note that this pin is not compatible with 3-Pin ARGB devices, and incorrect insertion may cause device damage.

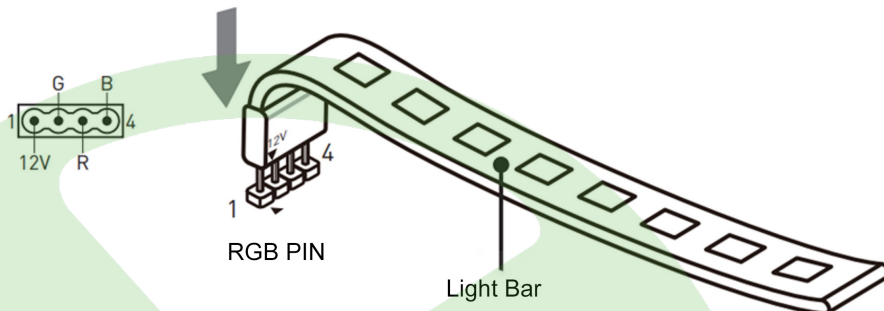

• SATA Port Installation

Used to connect SATA devices, use SATA data cables to connect SATA devices to the SATA interface on the motherboard, with a maximum interface speed of 6 Gb/s. Some SATA devices (such as SATA hard drives) also need to be connected to an additional power cord for use.

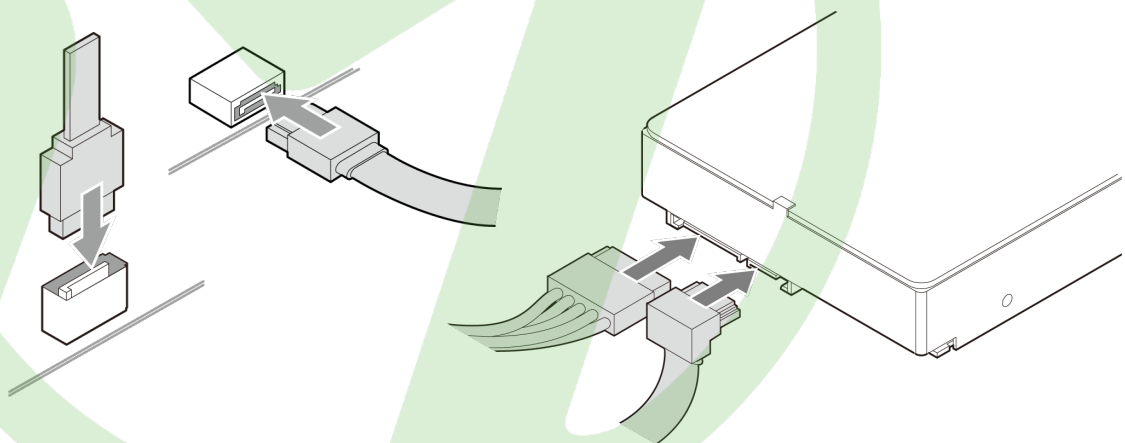

Installation Instructions

• 10-1 PIN F-PANEL System Panel PIN Installation

Pin on the front panel of the chassis, used to connect the on/off key, restart key, power indicator light, and hard drive indicator light of the chassis.

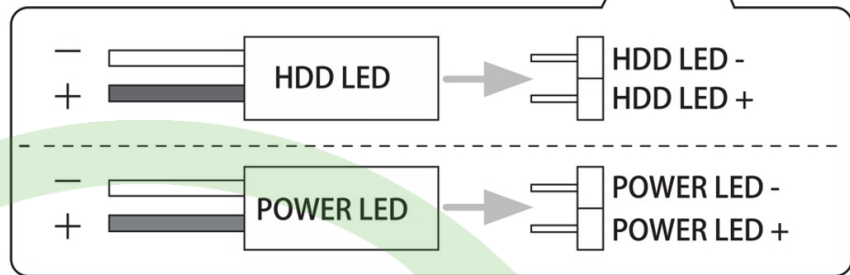
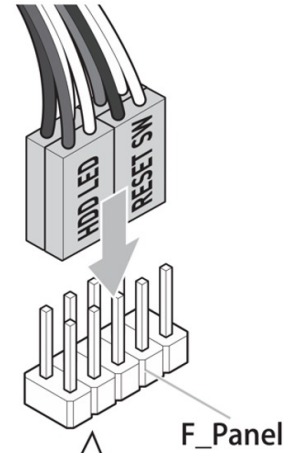
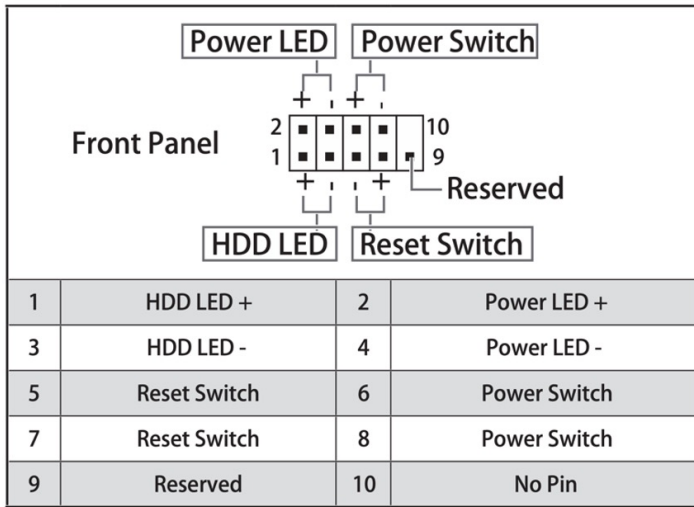

• F-AUDIO Front Panel Audio PIN Installation

Audio pin on the front panel of the chassis, used to connect the audio module on the front panel of the chassis.

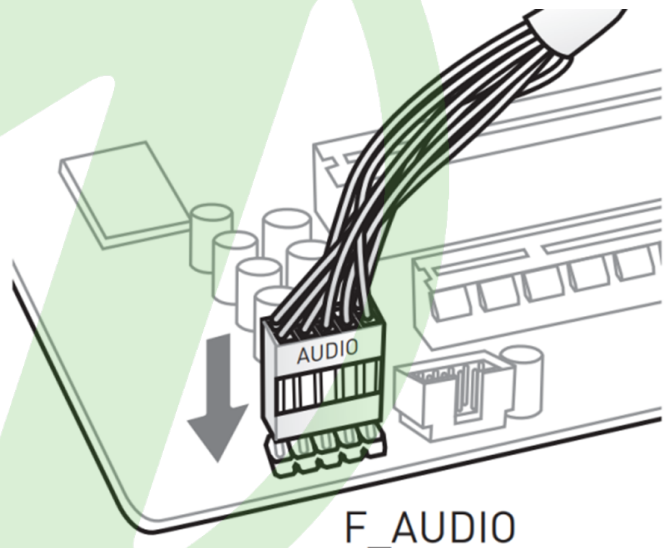
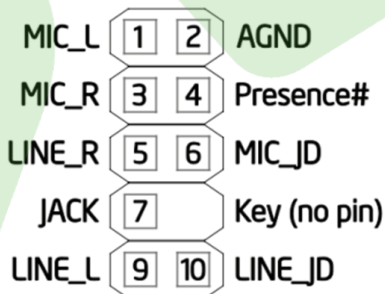

Guidelines for Rear I/O Port

- **USB 2.0 Type-A**

Used to connect USB Type-A device. The interface protocol is USB 2.0, with a data transfer rate of up to 480 Mbps. It is recommended to connect USB Type-A devices such as keyboards, mouse, and USB headphones that do not require high transfer speeds.

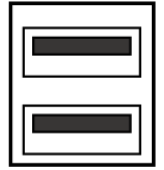

- **USB 3.2 Type-A**

Used to connect USB Type-A device. The interface protocol varies depending on the design of the motherboard, with two specifications available: USB 3.2 Gen1 or USB 3.2 Gen2. Please refer to the corresponding specifications of the motherboard for details. Suggested for connecting USB Type-A devices such as USB drives and portable hard drives that require high transmission speed.

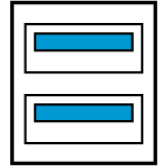

- **P/S2**

Used to connect devices such as P/S2 keyboards or mouse.

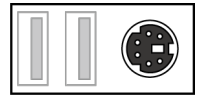

- **USB Type-C®**

Used to connect USB Type-C ® device. The interface protocol varies depending on the design of the motherboard. Please refer to the corresponding specifications of the motherboard for details. It is recommended to use it to connect USB Type-C devices such as USB drives and portable hard drives that require high transmission speed ® device.



- **HDMI™**

Used to connect HDMI ™ display device. The protocol version of this interface varies depending on the design of the motherboard. Please refer to the corresponding specifications of the motherboard for details.



- **DisplayPort**

Used to connect DP display device. The protocol version of this interface varies depending on the design of the motherboard. Please refer to the corresponding specifications of the motherboard for details.



- **RJ45 LAN**

Used to connect RJ45 LAN cables. The speed of this port varies depending on the design of the motherboard. Please refer to the corresponding specifications of the motherboard for details.

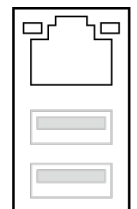

RJ45 LAN LED Status Indicator Light

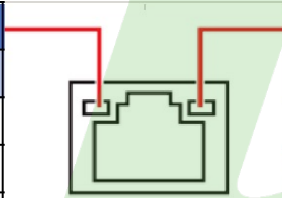
Activity Link LED			Speed LED	
Status	Description		Status	Description
Off	No link	Off	10Mbps connection	
Orange	Linked	Green	100 / 1000Mbps connection	
Blinking	Data activity	Orange	2.5Gbps connection	

Guidelines for Rear I/O Port

- **WiFi Antenna Port (external screw and internal pin)**

For connecting Wi Fi antennas, please use a standard interface (internal screw external pin) for Wi Fi antenna connection.



- **5.1 Channel Audio Interface**

- I. MIC-IN interface (light pink) is used to connect input devices such as microphones;
- II. LINE-OUT interface (light green) is used to connect audio output devices such as speakers;
- III. LINE-IN interface (light blue) is used to connect audio input devices;



- **7.1 Channel Audio Interface**

- I. MIC-IN interface (light pink) is used to connect input devices such as microphones;
- II. LINE-OUT interface (light green) is used to connect audio output devices such as speakers;
- III. LINE-IN interface (light blue) is used to connect audio input devices;
- IV. C/SUB interface (light orange) is used to connect subwoofer channels;
- V. REAR interface (light gray) is used to connect surround sound channels;
- VI. SPDIF OUT fiber optic interface is used to connect power amplifiers, decoders, projectors, and other devices with corresponding interfaces;

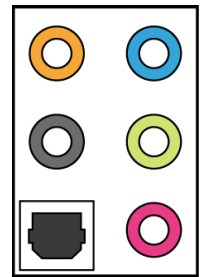



Product packaging

Motherboard products	1 x MS-Terminator B760M D5 Motherboard
Data cable	2 x SATA 6Gb/s Data cable
Other accessories	1 x M.2 SSD Screw pack
	1 x Wi-Fi Gain shielding box
	2 x Wi-Fi Gain antenna
	1 x Quick Guide

Specifications

Model	MS-Terminator B760M D5
Size	Micro-ATX 245mm x 245mm
CPU	The Intel® LGA1700 socket is compatible with 14th, 13th, and 12th generation Intel® Core™ processors, as well as Pentium® Gold and Celeron® processors.
Chipset	Intel® B760 Chipset
RAM	4x DIMM DDR5, maximum capacity 192GB Support dual-channel memory architecture Supports Intel® Extreme Memory Profile (XMP) Support 7600(OC)/7400(OC)/7200(OC)//6800(OC)/6600(OC)/6400(OC) /6200(OC)/6000(OC)/5800(OC)/5600/5400/5200/5000/4800Mhz memory frequency
Display	1x DisplayPort 1.4 display interface, supports up to 4K@60Hz 1x HDMI™ 1.4 display interface, supports up to 4K@30Hz *The graphics specifications of different types of CPUs may be different, please refer to the information on www.intel.com *
PCIe Expansion Slot	From Intel® 14th & 13th & 12th Gen Processors: 1x PCIe X16 slot (supports PCIe 5.0 X16 mode, supports X16 lane splitting, can be split into X8 + X8) From Intel® B760 Chipset: 1x PCIe X4 open slot (supports PCIe 3.0 X4 mode) 1x PCIe X1 slot (supports PCIe 3.0 X1 mode)
SSD	Supports 3x M.2 slots and 4x SATA 6Gb/s From Intel® 14th & 13th & 12th Gen Processors: M.2_A slot (Key_M): supports PCIe 4.0 X4/X2 mode, supports 2242 / 2280 length From Intel® B760 Chipset: M.2_B slot (Key_M): supports PCIe 4.0 X4/X2 mode, supports 2242 / 2280 /22110 length M.2_C slot (Key_M): supports PCIe 4.0 X4/X2 mode, supports 2242 / 2280 /22110 length 4x SATA 6Gb/s
LAN	1x Realtek RTL8125BG 2.5Gb LAN 1x M.2_WIFI slot (Key_E): supports CNVio2 channel for wireless
USB	Onboard USB (6 interfaces in total): 1x USB 3.2 Gen 2x2 Type-C® (20G) front port 1x USB 3.2 Gen 1 (5G) 19-Pin header, supports 2 additional USB 3.2 Gen1 1x USB 2.0 9-Pin header, supports 2 additional USB 2.0 1x USB 2.0 4-Pin header, supports 1 additional USB 2.0 Rear USB (9 interfaces in total): 2x USB 3.2 Gen 2 Type-A (10G) 6x USB 2.0 Type-A
Audio	Realtek ALC897 HD Audio chip

Rear I/O

4x USB 2.0 Type-A
1x CLR_CMOS button
1x DisplayPort 1.4
1x HDMI™ 1.4
2x USB 2.0 Type-A
2x USB 3.2 Gen 2 Type-A (10G)
1x Realtek 2.5Gb LAN
3x audio jacks

Built-in I/O

Power interface
24-Pin ATX power connector
(8 + 4)-Pin +12V power connector
Fan interface
1x 4-Pin CPU_FAN fan header
1x 4-Pin PUMP header (supports DC speed adjustment)
2x 4-Pin SYS_FAN chassis fan header
Storage interface
3x M.2 slot (Key_M)
4x SATA 6Gb/s
Onboard USB interface
1x USB 3.2 Gen 2x2 Type-C® (20G) front port
1x USB 3.2 Gen 1 (5G) 19-Pin header
1x USB 2.0 9-Pin header
1x USB 2.0 4-Pin header
Other interfaces
2x 3-Pin ARGB header
1x 4-Pin NRGB header
1x COM port header
1x front panel audio header
1x 10-1 Pin system panel header
1x CLR_CMOS reset header

Operating System

Windows® 11, Windows® 10 64-bit

Special Features

Distributed Debug lights
Maxsun Sync lighting control
CLR_CMOS button
Resizable bar technology

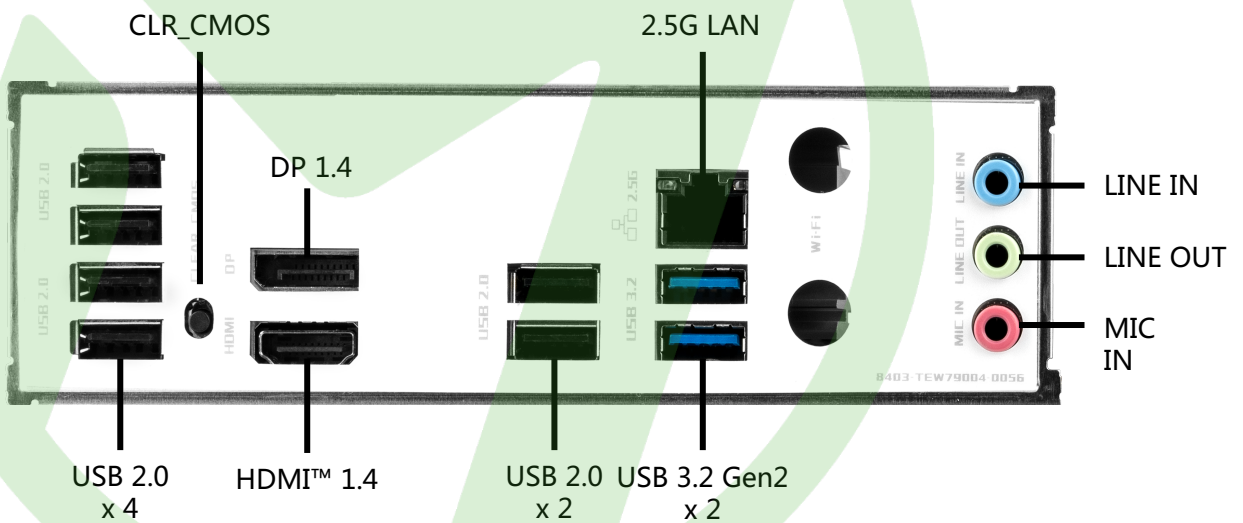
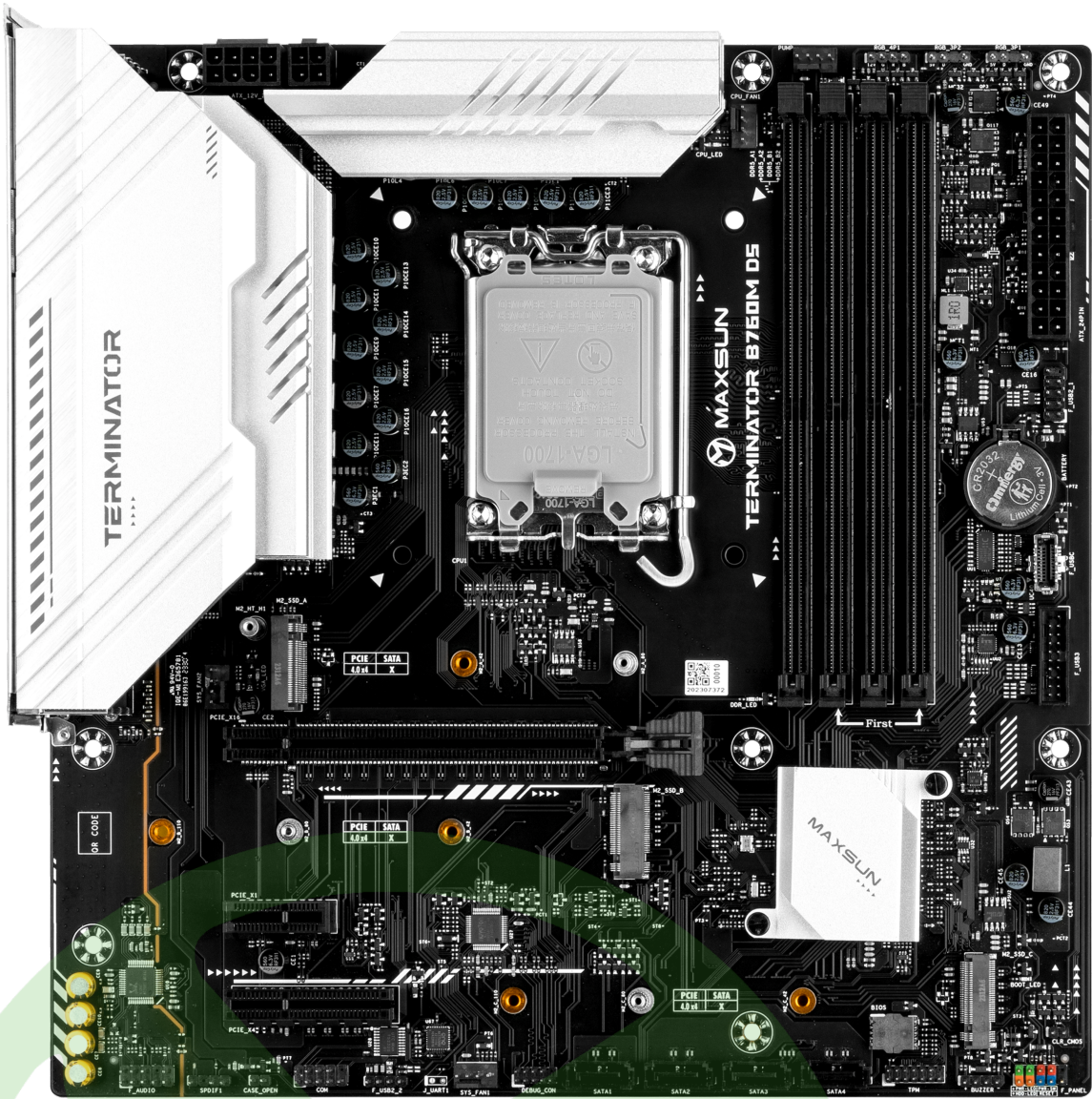



MAXSUN

Intel B760 Series BIOS

USERGUIDE

Motherboard

Contents

1 BIOS INTRODUCTION	3
1.1 BIOS DESCRIPTION	3
1.2 BIOS OPERATING INSTRUCTIONS	3
1.2.1 Instructions for entering BIOS	3
1.2.2 BIOS Mouse Instructions.....	3
1.2.3 BIOS Keyboard Instructions	3
1.3 PAGE INTRODUCTION.....	4
1.3.1 BIOS Pages :	4
1.3.2 Main menu page:	4
1.3.3 Option Selection Page	5
1.3.4 Option Description Area.....	5
1.3.5 Operating Instructions Area :	6
2、FUNCTIONS OF BIOS OPTIONS	6
2.1 MAIN :	6
2.2 ADVANCED :	8
2.2.1 Connectivity Configuration	9
2.2.2 CPU Configuration.....	11
2.2.3 SATA Configuration	14
2.2.4 NVMe Configuration	15
2.2.5 VMD setup menu	16
2.2.6 Chipset Configuration	17
2.2.7 Graphics Configuration.....	18
2.2.8 PCI Subsystem Settings	19
2.2.9 Trusted Computing	21
2.2.10 NCT5585D Super IO Configuration.....	22
2.2.11 Hardware Monitor	23
2.2.12 USB Configuration	25
2.2.13 No Disk (PXE)	26
2.3 POWER :	27
2.4 TURBO :	28
2.5 STARTUP:	32
2.6 SECURITY:	33
2.7 EXIT:.....	34

1、 BIOS Introduction

1.1 BIOS Description

BIOS is called Basic Input/Output System. When you turn on your computer, BIOS is the first program to run, and the modified BIOS data will be stored in a CMOS RAM maintained by the battery, and will not be lost when the power is cut off. Normally, no BIOS modification is necessary when the system is running normally, but if the CMOS data is lost due to battery depletion, the battery has to be replaced and the BIOS value has to be reset.

Note: BIOS interface options and functions may vary depending on the actual version, please refer to the actual version.

1.2 BIOS Operating Instructions

1.2.1 Instructions for entering BIOS

To enter the BIOS setup program screen, please follow the steps below:

Turn on the power or reboot the system and wait until the screen displays "Pressto enter setup.";

Press to enter the BIOS setup program.

1.2.2 BIOS Mouse Instructions

Left->Select, Right->Exit

1.2.3 BIOS Keyboard Instructions

< → >/< ← >	The next display screen selected to the right or left
< ↑ >/< ↓ >	Up or Down Selection
<Enter>	Select a value or option
< + >/< - >	Changing values or selections
< F1 >	Topic help,available only in the Status Display menu and the Selection Settings menu
< F7 >	Discard the changes made and use the value set before the modification.
< F9 >	Load preset optimization settings
< F10 >	Save the changed CMOS settings and exit
< ESC >	Exit

1.3 Page Introduction

1.3.1 BIOS Pages :



B760 motherboard BIOS is divided into a total of four functional areas, respectively, the main menu area, option selection area, option description area, operation description area.

1.3.2 Main menu page:

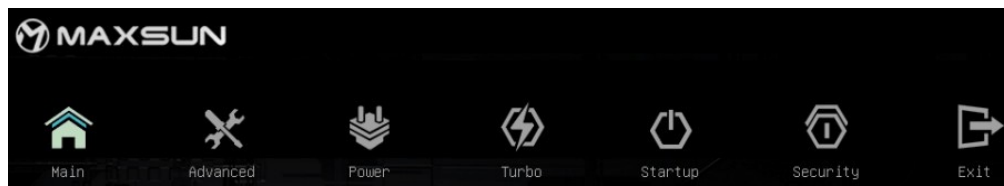

The main menu page has seven main menus, Main, Advanced, Power, Turbo, Startup, Security, and Exit.

1.3.3 Option Selection Page :



The option selection page displays the content of the options and allows the user to select the functional options that need to be modified using the mouse or keyboard (the screenshot shows the first level of options for Advanced).

1.3.4 Option Description Area :



The function of this area is to provide a descriptive explanation of the selected options.

1.3.5 Operating Instructions Area :

UEFI BIOS Utility V1.3 / F1->General Help, F2->Save Profile, F3->Load Profile, F8->Ez Update, F12->Screen Shot, Right

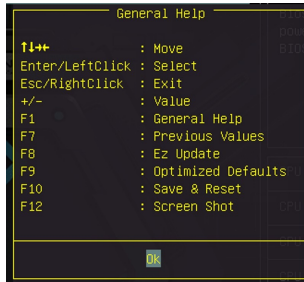

This area is located at the bottom right of the main interface, the main function of the shortcut buttons for simple operation instructions.

2、 Functions of BIOS Options

2.1 Main :

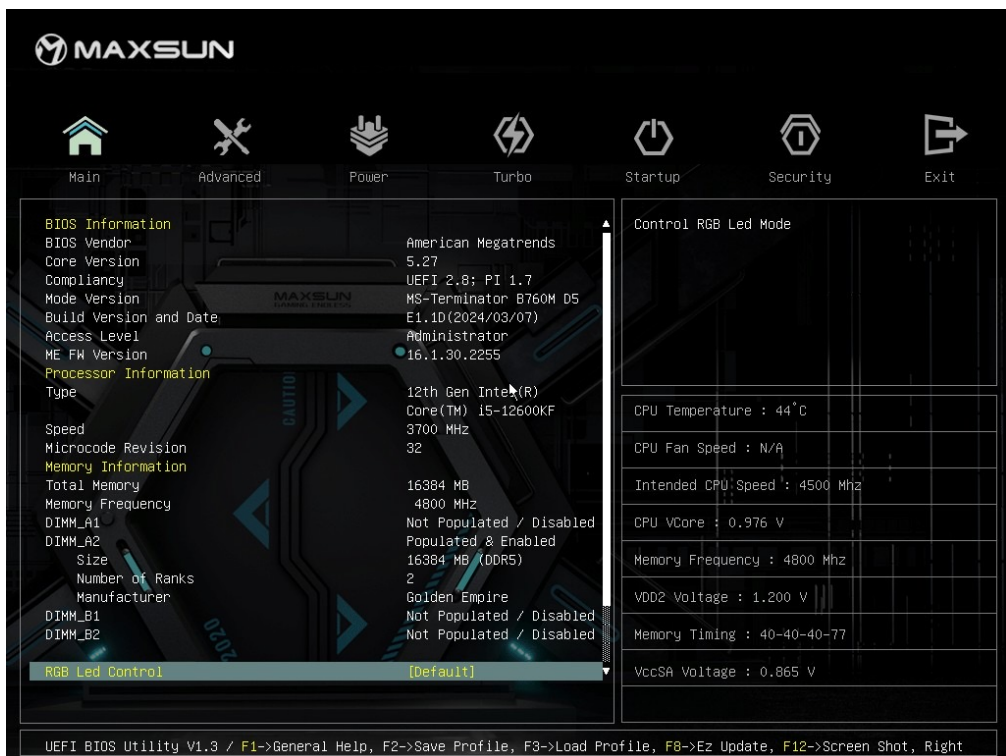

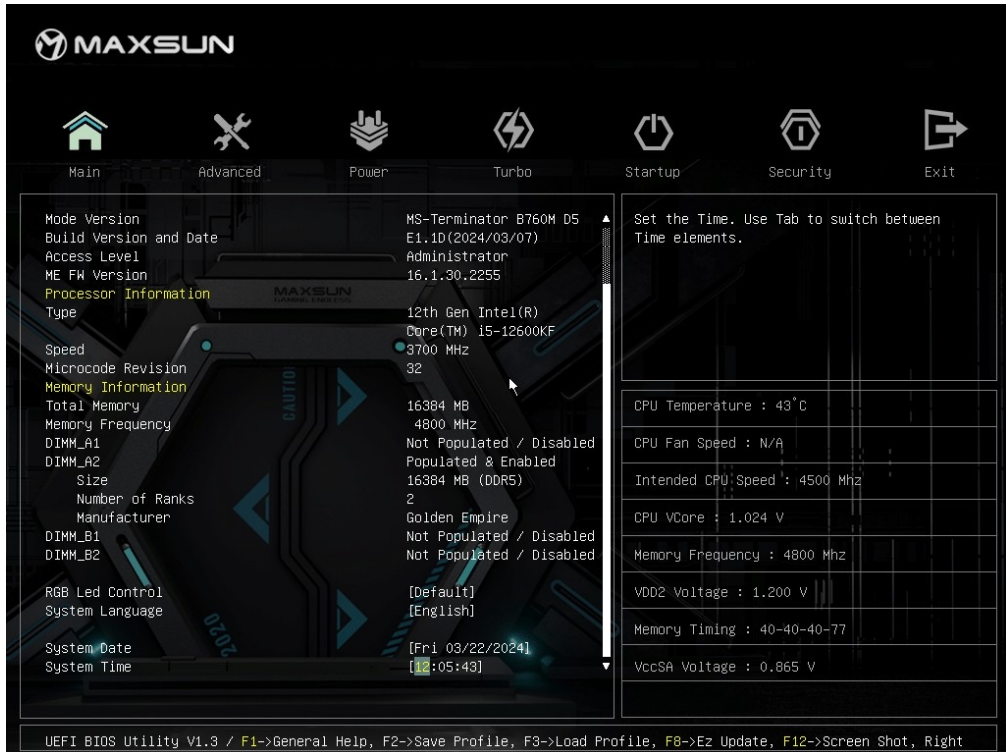

▶ BIOS Information

Shows detailed BIOS information, including CPU type, manufacturer, model, BIOS version, and memory, etc (read only).

▶ Processor Information

Display detailed processor information, including processor model, processor frequency, and Microcode Revision (read-only).

▶ Memory Information

Display detailed memory information, including memory brand, memory capacity, and memory frequency (read-only).

▶ RGB Led Control

Controls the motherboard RGB Led on and off.

▶ System Language

Press the Enter key or the space bar to change the BIOS language, select Simplified Chinese or English.

▶ System Date

Change the system date in <week><month><day><year> format.

▶ System Time

Change the system time in <hour><minute><second> format.

2.2 Advanced :



▶ Connectivity Configuration

Configuring the CNVI WiFi module.

▶ CPU Configuration

Intel processor parameter settings.

▶ SATA Configuration

SATA disk information and configuration of SATA disks.

▶ NVMe SSD Configuration

Information on NVMe protocol SSD and configuring NVMe protocol SSD.

▶ VMD setup menu

RAID function enable and disable control.

▶ Chipset Configuration

Changing chipset related functional configurations.

▶ **Graphics Configuration**

Integrated graphics card related configurations.

▶ **PCI Subsystem Settings**

Configuration of PCIE interfaces.

▶ **Trusted Computing**

TPM2.0 configuration changes, Windows11 installations require this option to be turned on.

▶ **NCT5585D Super IO Configuration**

Changing COM port configuration information.

▶ **Hardware Monitor**

Monitor the real-time status of the motherboard hardware, e.g. the CPU fan.

▶ **USB Configuration**

Configure and view information about each USB port.

▶ **No Disk**

Configuration of disk-less network(PXE) and related functions.

2.2.1 Connectivity Configuration

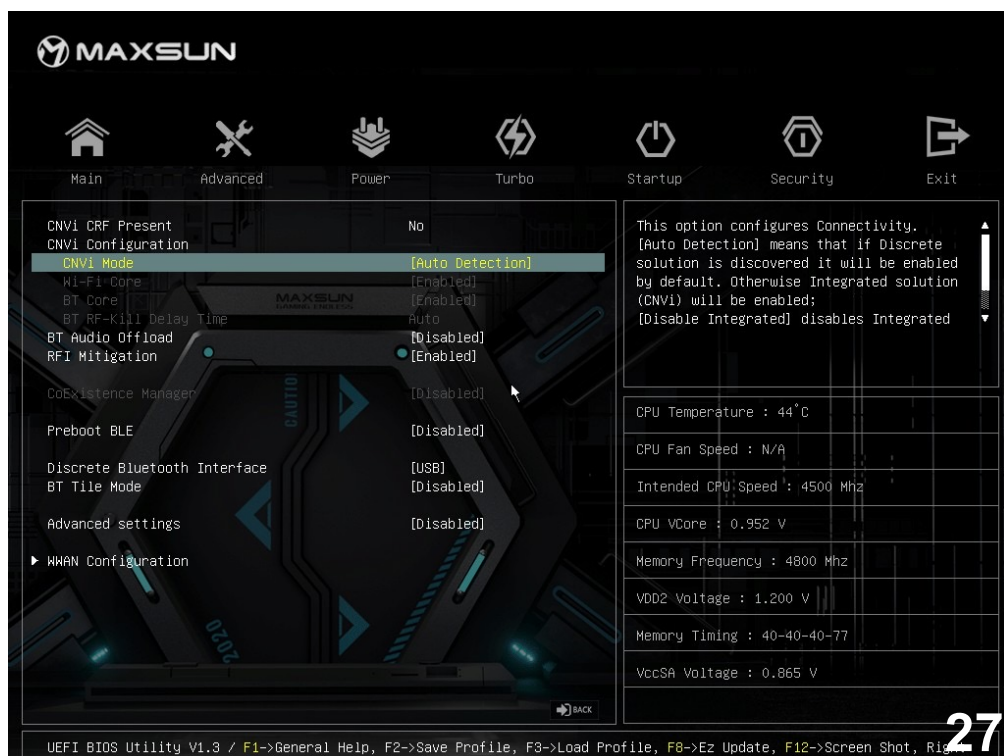

▶ **CNVI Mode**

CNVI WiFi module on/off control.

▶ **RFI Mitigation**

RFI buffer on/off control.

▶ **Preboot BLE**

Preboot BLE mode on/off control.

▶ **Discrete Bluetooth Interface**

Bluetooth interface modification control.

▶ **BT Tile Mode**

Bluetooth tile mode on/off control.

▶ **Advanced setting**

CNVI WiFi module advanced setup on/off control.

▶ **WWAN Configuration**

Wireless NIC device type selection and function setting.

2.2.2 CPU Configuration

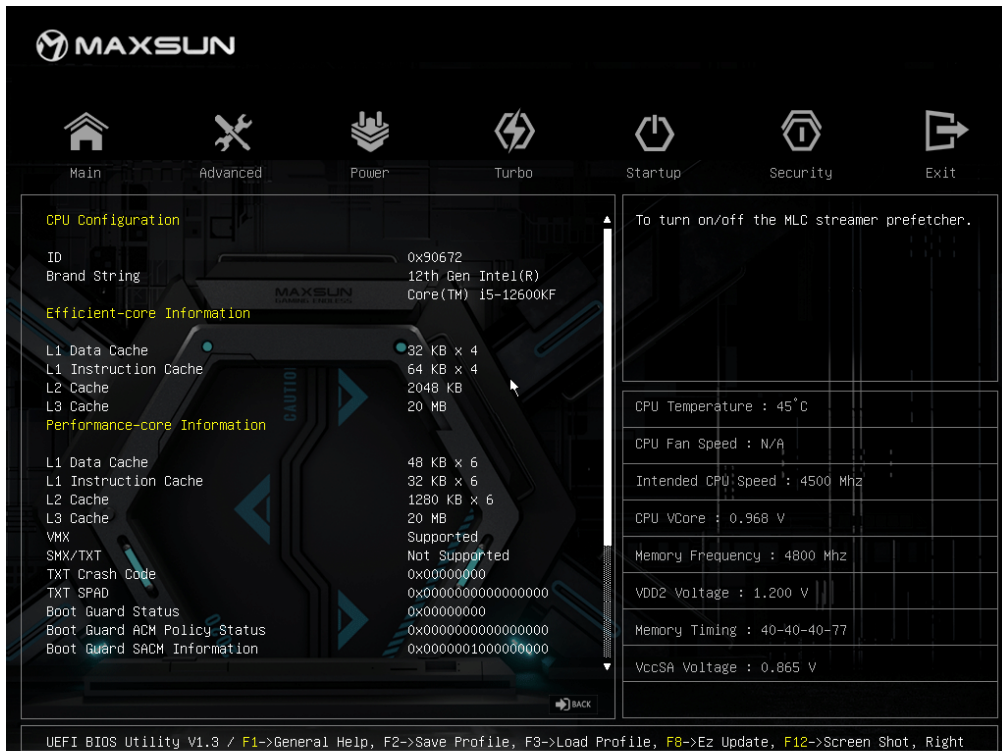

MAXSUN

Main Advanced Power Turbo Startup Security Exit

CPU Configuration

ID 0x90672
 Brand String 12th Gen Intel(R)
 Core(TM) i5-12600KF

Efficient-core Information

L1 Data Cache 32 KB x 4
 L1 Instruction Cache 64 KB x 4
 L2 Cache 2048 KB
 L3 Cache 20 MB

Performance-core Information

L1 Data Cache 48 KB x 6
 L1 Instruction Cache 32 KB x 6
 L2 Cache 1280 KB x 6
 L3 Cache 20 MB
 VMX Supported
 SMX/TXT Not Supported
 TXT Crash Code 0x00000000
 TXT SPAD 0x0000000000000000
 Boot Guard Status 0x00000000
 Boot Guard ACM Policy Status 0x0000000000000000
 Boot Guard SADM Information 0x0000000100000000

To turn on/off the MLC streamer prefetcher.

CPU Temperature : 45°C
 CPU Fan Speed : N/A
 Intended CPU Speed : 4500 Mhz
 CPU VCore : 0.968 V
 Memory Frequency : 4800 Mhz
 VDD2 Voltage : 1.200 V
 Memory Timing : 40-40-40-77
 VccSA Voltage : 0.865 V

UEFI BIOS Utility V1.3 / F1->General Help, F2->Save Profile, F3->Load Profile, F8->Ez Update, F12->Screen Shot, Right



MAXSUN

Main Advanced Power Turbo Startup Security Exit

L3 Cache 20 MB

Performance-core Information

L1 Data Cache 48 KB x 6
 L1 Instruction Cache 32 KB x 6
 L2 Cache 1280 KB x 6
 L3 Cache 20 MB
 VMX Supported
 SMX/TXT Not Supported
 TXT Crash Code 0x00000000
 TXT SPAD 0x0000000000000000
 Boot Guard Status 0x00000000
 Boot Guard ACM Policy Status 0x0000000000000000
 Boot Guard SADM Information 0x0000000100000000

When enabled, Pressing the scroll lock key will toggle the Efficient-cores between being parked when Scroll Lock LED is on and un-parked when LED is off.

CPU Temperature : 45°C
 CPU Fan Speed : N/A
 Intended CPU Speed : 4500 Mhz
 CPU VCore : 0.968 V
 Memory Frequency : 4800 Mhz
 VDD2 Voltage : 1.200 V
 Memory Timing : 40-40-40-77
 VccSA Voltage : 0.865 V

Hardware Prefetcher [Enabled]
 Adjacent Cache Line Prefetch [Enabled]
 Intel (VMX) Virtualization Technology [Disabled]
 Active Performance-cores [All]
 Active Efficient-cores [All]
 Hyper-Threading [Enabled]
 C states [Enabled]
 Enhanced C-states [Enabled]
 Package C State Limit [Auto]
 Legacy Game Compatibility Mode [Disabled]

UEFI BIOS Utility V1.3 / F1->General Help, F2->Save Profile, F3->Load Profile, F8->Ez Update, F12->Screen Shot, Right

▶ CPU Configuration

CPU detailed information.

▶ Efficient Core Information

E-core information show.

▶ Performance Core Information

P-core information show.

▶ Hardware Prefetcher

Control hardware prefetch option, means the CPU has a hardware prefetch function, before the CPU processes instructions or data, it will prefetch these instructions or data from memory to the L2 cache, thus reducing the time of memory read, helping to eliminate potential bottlenecks, so as to improve the system performance, options: [disabled], [enabled].

▶ Adjacent Cache Line Prefetch

Controls the pre-reading of neighboring cached data. When the computer reads data, it will intelligently think that the data to be read next to or adjacent to the data is also needed, then it will be processed when the neighboring data will be read out in advance, which will greatly accelerate the speed of reading, options: [disabled], [enabled].

▶ Intel (VMX) Virtualization technology

Supports Intel virtualization technology that allows a platform to run multiple operating systems in separate partitions. The system can run multiple systems virtually, options: [disabled], [enabled].

▶ Active Performance Cores

This option is used to set the number of cores to activate performance cores. The options correspond to the number of CPU performance cores used: ALL (enable all performance cores), 1 (enable one performance core), 2 (enable two performance cores).

▶ Active Efficient Cores

This option is used to set the number of hardware cores to activate E-core. The options correspond to the number of CPU mini-core cores used: ALL (enable all efficient cores), 1 (enable one efficient core), 2 (enable two efficient cores), 0 (disable all efficient cores).

▶ Hyper-Threading

Intel Hyper-Threading technology treats the multi cores inside the processor as multi logical processors that can execute instructions simultaneously. In this way, the system performance is highly improved. This item appears when the installed CPU supports this technology, options: [disabled], [enabled].

▶ **C states**

Controls processor power states to manage energy consumption by transitioning between idle states efficiently.

▶ **Enhanced C-states**

Offers deeper sleep states for CPU cores, enhancing power-saving capabilities during periods of low activity.

▶ **Package C states Limit**

Adjusts the maximum allowed sleep states for the CPU package, optimizing power efficiency.

▶ **Legacy Game Compatibility Mode**

Controls to turn on or off the computer's traditional gaming modes, options: [disabled], [enabled].

2.2.3 SATA Configuration

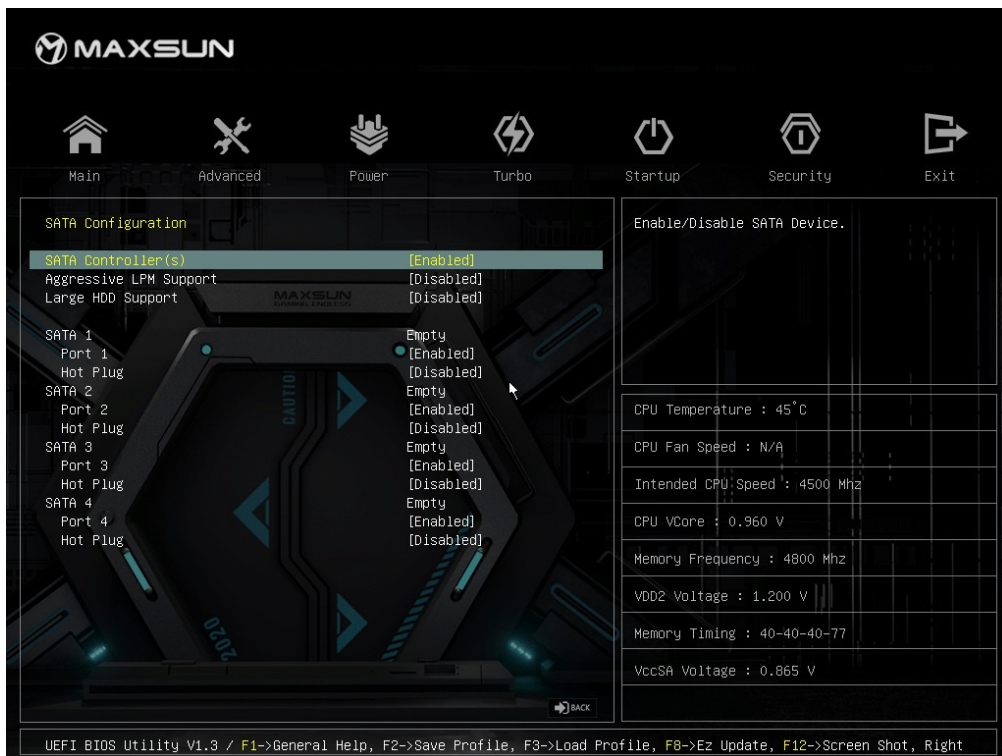

▶ SATA Controller(s)

Controls whether the SATA interface is used, options: [disabled], [enabled].

▶ Aggressive LPM Support

Enables aggressive low-power modes for system components, enhancing energy savings during idle states.

▶ Large HDD Support

Control to turn on or off large storage capacity device support, options: [disabled], [enabled].

▶ Port (1-4)

Control to turn on or off the corresponding SATA disk device, options: [disabled], [enabled].

▶ Hot Plug

Control to turn on or off the hot-plug state of the corresponding SATA disk, options: [disabled], [enabled].

2.2.4 NVMe Configuration

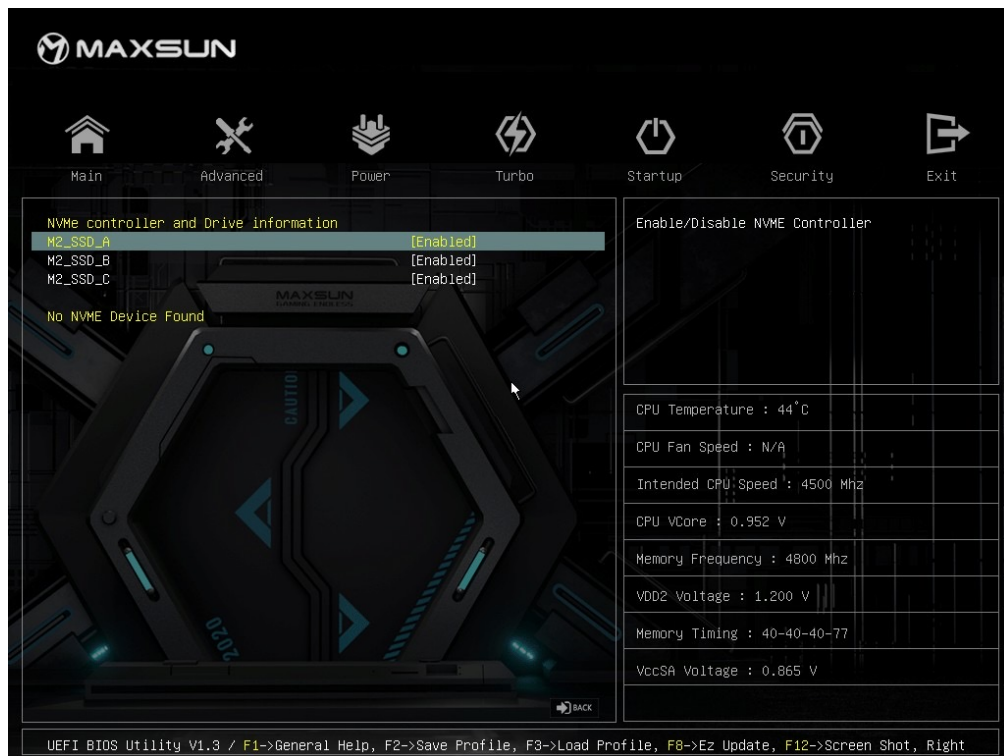

▶ M2_SSD_A

Controls whether the M2_A SSD interface is used, options: [disabled], [enabled].

▶ M2_SSD_B

Controls whether the M2_B SSD interface is used, options: [disabled], [enabled].

▶ M2_SSD_C

Controls whether the M2_C SSD interface is used, options: [disabled], [enabled].

2.2.5 VMD setup menu



▶ Enable VMD Controller

Controlling RAID Functions, options: [disabled], [enabled].

Save and reboot into the BIOS interface, users can set RAID0, RAID1, RAID5, RAID10 four modes.

2.2.6 Chipset Configuration



▶ HD Audio Configuration

Controls motherboard audio functions on or off, options: [disabled], [enabled].

▶ Power Management Control

Controls the motherboard chipset power saving management options on or off, options: [disabled], [enabled].

2.2.7 Graphics Configuration

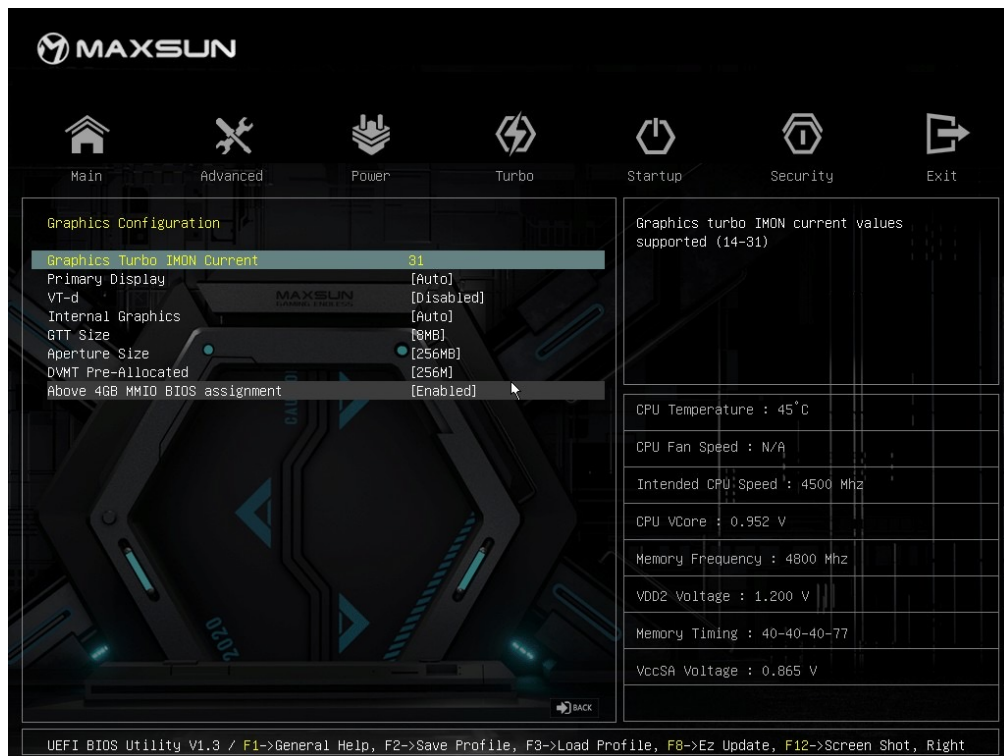

▶ Graphics Turbo IMON Current

Display supported graphics card turbo IMON current values (14-31).

▶ Primary Display

Controls the motherboard's default display modes, with Auto (default discrete graphics card priority output), IGFX (simultaneous output of integrated and discrete graphics cards), and PEG Slot (discrete graphics card priority output),

▶ VT-d

Enables or disables Intel VT-D (Intel Virtualization for Directed I/O) technology, options: [disabled], [enabled].

▶ Internal Graphics

Controls CPU integrated output in three modes: auto, on, or off.

▶ GTT Size

Setting the VGA memory size capacity (2-8MB).

▶ Aperture Size

Setting the buffer allocation size (128MB、256MB、512MB).

▶ DVMT Pre-Allocated

Setting dynamic shared VGA memory presets (32-512MB).

▶ Above 4G MMIO BIOS assignment

Control to turn on or off MMIO BIOS allocation for 4G or more.

2.2.8 PCI Subsystem Settings

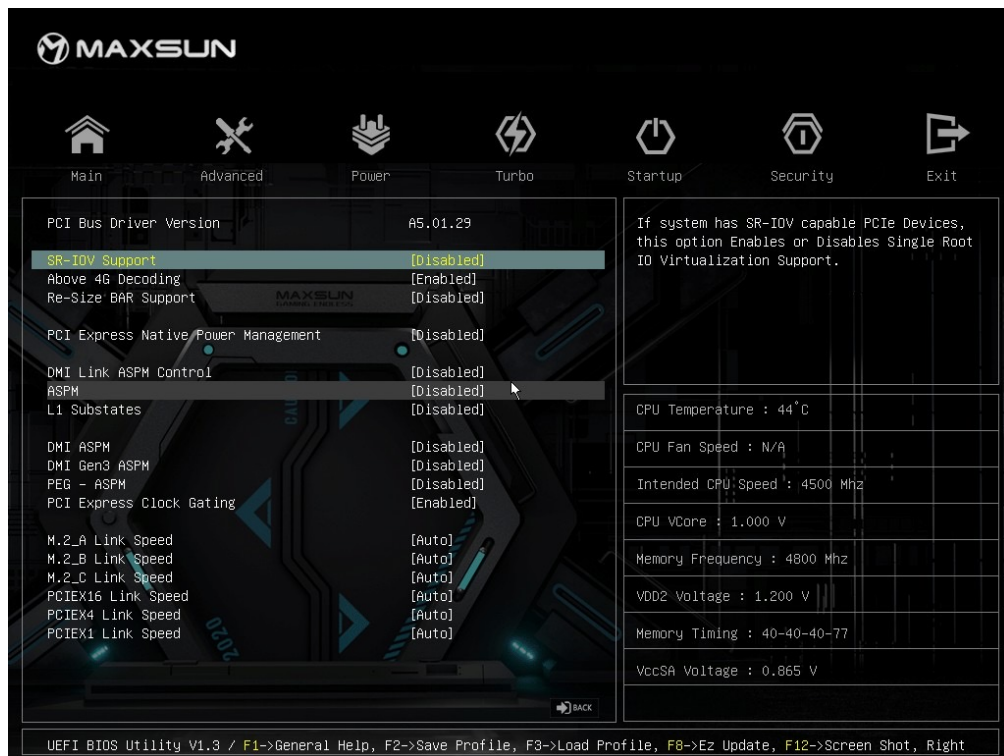

▶ SR-IOV Support

Activates Single Root I/O Virtualization, enabling efficient sharing of PCIe devices among virtual machines.

▶ Above 4G Decoding

Enables or disables 64-bit capable devices to be decoded in above 4G address space.

It is only available if the system supports 64-bit PCI decoding, options: [disabled], [enabled].

▶ Re-size BAR Support

Enables or disables the Resize BAR (Base Address Register) support. It is only available if the system supports 64-bit PCI/ PCIe decoding. If the system supports 64-bit PCI/ PCIe decoding, please enable this item for compatible PCIe device.

Attention: Enabling the Re-Size BAR support feature requires the following four conditions to be met simultaneously.

- 1、Above 4G Decoding is Enabled.
- 2、Re-size BAR Support is Enabled.
- 3、Discrete graphics card using AMD 6000 series above PCIE4.0 graphics card, NVIDIA 30 series above PCIE4.0 graphics card. Such as AMD 6800xt, RTX 3060, RTX 4060 etc.
- 4、CSM is Disabled.

PCI Express Native Power Management

Manages power states of PCIe devices natively for improved energy efficiency.

DMI Link ASPM Control

Controls ASPM for Direct Media Interface links, optimizing power usage for interconnects.

ASPM

Activates Active State Power Management for PCIe devices, reducing power consumption during idle periods.

L1 Substates

Controls power-saving states for PCIe links, enhancing energy efficiency during low data activity.

DMI ASPM

Manages ASPM specifically for Direct Media Interface connections, optimizing power usage.

DMI Gen3 ASPM

Optimizes ASPM support for third-generation Direct Media Interface connections, enhancing power efficiency.

PEG – ASPM

Manages ASPM for PCI Express Graphics (PEG) slots, optimizing power usage for graphics cards.

PCI Express Clock Gating

Controls clock gating for PCIe devices, reducing power consumption by disabling clocks during idle periods.

M.2_A/B/C Link Speed

Sets the speed for M.2 SSD connections, optimizing data transfer rates according to device capabilities.

PCIEX16/PCIEX4/PCIEX1 Link Speed

Adjusts the speed of PCIe slots, optimizing bandwidth for connected devices.

2.2.9 Trusted Computing

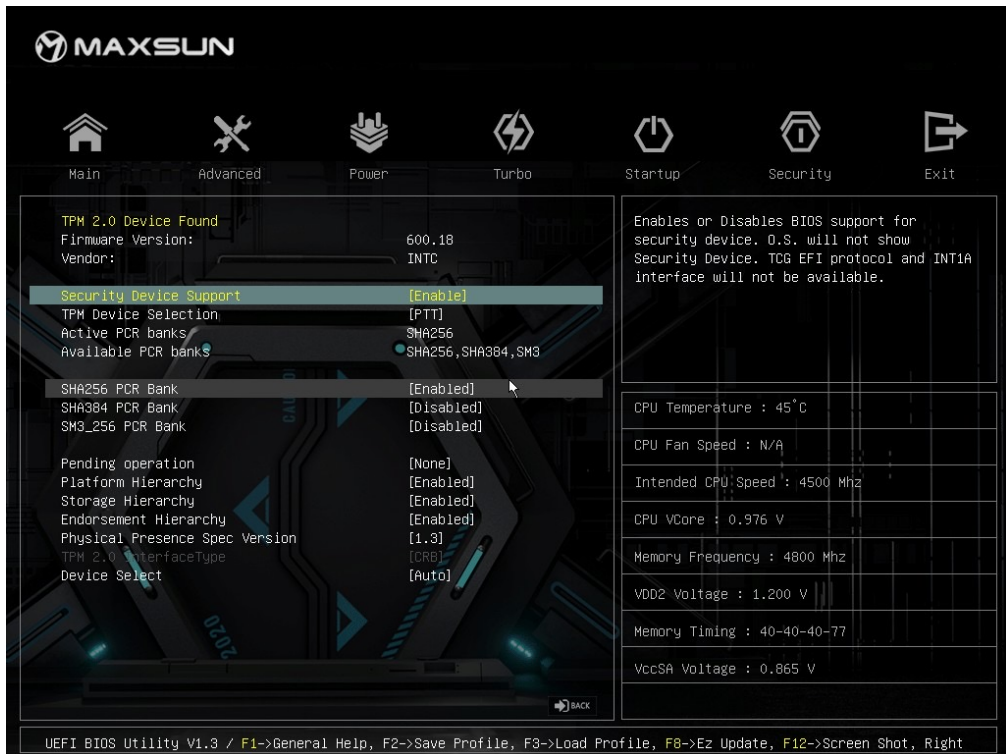

▶ Security Device Support

Control to enable or disable TPM support, options: [disabled], [enabled].

▶ TPM Device Selection

TPM device selection, divided into dtmp (external standalone TPM device) and PTT (built-in TPM device).

▶ SHA256 PCR Bank

Control to turn the SHA256 algorithm on or off, options: [disabled], [enabled].

▶ SHA384 PCR Bank

Control to turn the SHA384 algorithm on or off, options: [disabled], [enabled].

▶ SM3_256 PCR Bank

Control to turn the SM3_256 algorithm on or off, options: [disabled], [enabled].

▶ Pending operation

Sets the options when waiting for an operation, which can be set to None or TPM Clear.

▶ Platform Hierarchy

Control to turn on or off the TPM platform structure, options: [disabled], [enabled].

▶ Storage Hierarchy

Control to turn on or off the TPM storage structure, options: [disabled], [enabled].

▶ Endorsement Hierarchy

Control to turn on or off the hierarchy of TPM support, options: [disabled], [enabled].

▶ Physical Presence Spec Version

Setting the operating version of the TPM physical presence, optionally version 1.2 or 1.3.

▶ Device Select

Set up TPM device selection with Auto, TPM1.2, and TPM2.0 to choose from.

2.2.10 NCT5585D Super IO Configuration

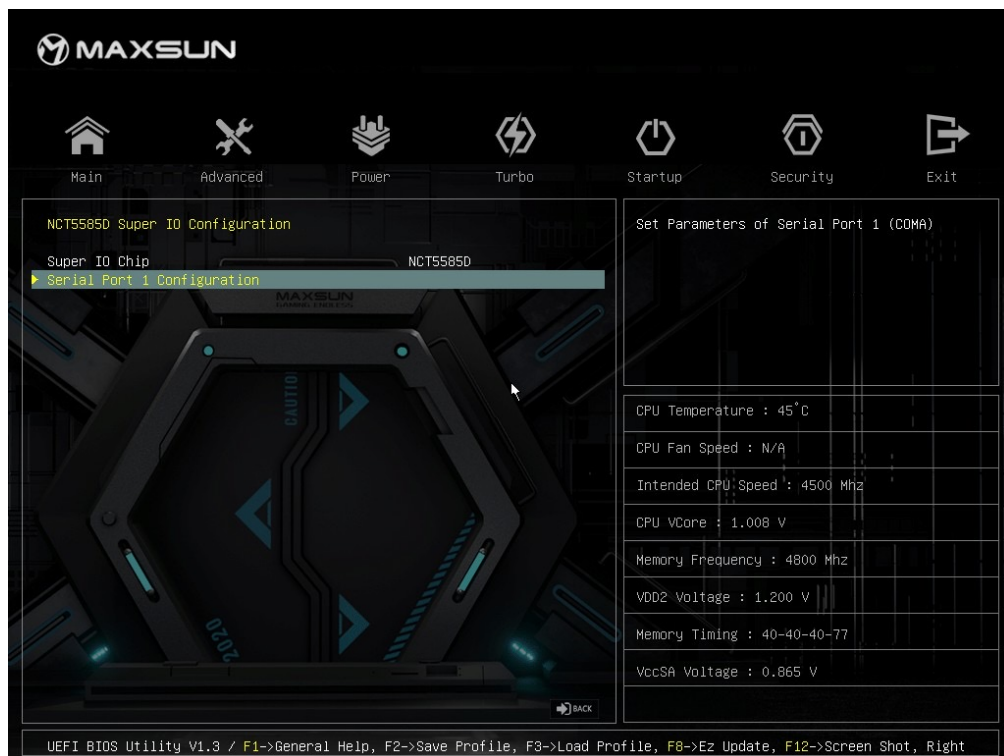

▶ Serial Port 1 Configuration

Controls the opening and closing of the motherboard's COM ports, as well as parameterizing the COM ports.

2.2.11 Hardware Monitor



MAXSUN

Main Advanced Power Turbo Startup Security Exit

Pc Health Status

CPU temperature	: +46 °C
SYS temperature	: +31 °C
CPU_FAN Speed	: N/A
SYS_FAN1 Speed	: N/A
SYS_FAN2 Speed	: N/A
SYS_FAN3 Speed	: 793 RPM
CPU Vcore	: +1.032 V
VDD2 Voltage	: +1.200 V
+VCCIN_AUX	: +1.800 V
+1.05V	: +1.078 V
VBAT	: +3.104 V

Smart Fan Function

Smart Fan function setting

CPU Temperature	: 46 °C
CPU Fan Speed	: N/A
Intended CPU Speed	: 4500 Mhz
CPU VCore	: 1.032 V
Memory Frequency	: 4800 Mhz
VDD2 Voltage	: 1.200 V
Memory Timing	: 40-40-40-77
VccSA Voltage	: 0.865 V

UEFI BIOS Utility V1.3 / F1->General Help, F2->Save Profile, F3->Load Profile, F8->Ez Update, F12->Screen Shot, Right

▶ Pc Health Status

Displays monitored values and status of CPU temperature, fan, CPU voltage, etc.

Option name	Option Functions	Available Options			
CPU_Fan Control	Controls the speed of the fan plugged into the CPU Fan pin (Note: the fan itself must support speed control)	Normal (System auto-adjustment)	Full (full speed)	Manual (Manual speed adjustment)	CPU Temperature (Varies with CPU temperature) System Temperature (Varies with motherboard temperature)
Sys_Fan1 Control	Controls the speed of the fan plugged into the Sys Fan1 pin (Note: the fan itself must support speed control)	Normal (System auto-adjustment)	Full (full speed)	Manual (Manual speed adjustment)	CPU Temperature (Varies with CPU temperature) System Temperature (Varies with motherboard temperature)
Sys_Fan2 Control	Controls the speed of the fan plugged into the Sys Fan2 pin (note: the fan product itself must support speed control)	Normal (System auto-adjustment)	Full (full speed)	Manual (Manual speed adjustment)	CPU Temperature (Varies with CPU temperature) System Temperature (Varies with motherboard temperature)
Pump_Fan Control	Controls the speed of the fan plugged into the Pump Fan pin (note: the fan itself must support speed control)	Normal (System auto-adjustment)	Full (full speed)	Manual (Manual speed adjustment)	CPU Temperature (Varies with CPU temperature) System Temperature (Varies with motherboard temperature)

2.2.12 USB Configuration

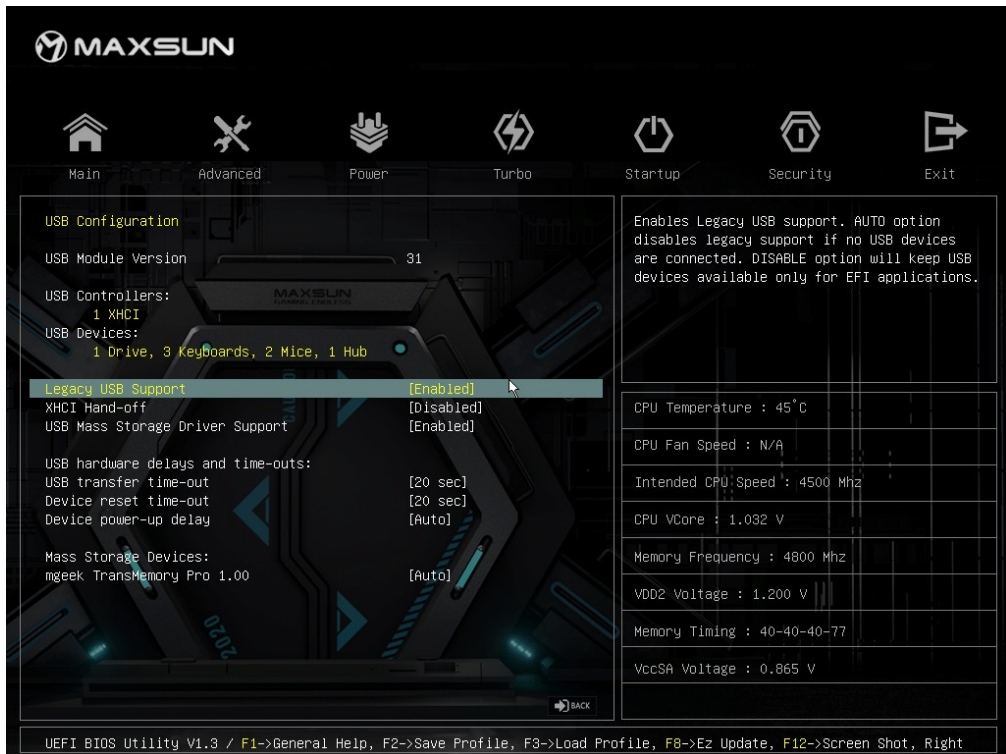

▶ Legacy USB Support

Setup for supporting older legacy USB device, options: [disabled], [enabled].

▶ XHCI Hand-off

XHCI is an extensible host controller interface, and this option sets whether the XHCI relay function is supported, options: [disabled], [enabled].

▶ USB Mass Storage Device Support

Control to turn on or off the USB interface of mass storage devices, such as USB flash drives, removable hard drives, etc.

▶ USB transfer time-out

USB transfer timeout value time setting (1-20sec).

▶ Device reset time-out

USB command timeout setting (10-40sec).

▶ Device power-up delay

USB boot delay time setting, divided into Auto and Manual.

2.2.13 No Disk (PXE)



MAXSUN

Main Advanced Power Turbo Startup Security Exit

Onboard Lan1 Controller [Enabled]

Legacy PXE Support [Disabled]

UEFI PXE Support [Disabled]

Enable/Disable Onboard Lan Controller

CPU Temperature : 46°C

CPU Fan Speed : N/A

Intended CPU Speed : 4500 Mhz

CPU VCore : 1.008 V

Memory Frequency : 4800 Mhz

VDD2 Voltage : 1.200 V

Memory Timing : 40-40-40-77

VccSA Voltage : 0.865 V

UEFI BIOS Utility V1.3 / F1->General Help, F2->Save Profile, F3->Load Profile, F8->Ez Update, F12->Screen Shot, Right



MAXSUN

Main Advanced Power Turbo Startup Security Exit

Driver Information

Driver Name: Realtek UEFI UNDI Driver

Driver Version: 2.063

Driver Released Date: 2023/08/23

Device Information

Device Name: Realtek PCIe 2.5GBE Family Controller

PCI Slot: 03:00:00

MAC Address: 00:E2:69:7E:F4:67

Patent Information

This product is covered by one or more of the following patents:
US6,570,884, US6,115,776, and US6,327,625

CPU Temperature : 45°C

CPU Fan Speed : N/A

Intended CPU Speed : 4500 Mhz

CPU VCore : 1.032 V

Memory Frequency : 4800 Mhz

VDD2 Voltage : 1.200 V

Memory Timing : 40-40-40-77

VccSA Voltage : 0.865 V

UEFI BIOS Utility V1.3 / F1->General Help, F2->Save Profile, F3->Load Profile, F8->Ez Update, F12->Screen Shot, Right

▶ Onboard LAN Controller

Enables or disables the onboard LAN controller, options: [disabled], [enabled].

▶ Legacy PXE Support

When Enabled, the system Legacy network stack will support Ipv4 protocol. This item will appear when Network Stack is enabled.

▶ UEFI PXE Support

When Enabled, the system UEFI network stack will support Ipv4/Ipv6 protocol. This item will appear when Network Stack is enabled.

2.3 Power :



▶ ACPI Setting (ACPI Energy saving)

- I Enable Hibernation: Set whether to enable the hibernation (S4) function, options: [disabled], [enabled].
- I ACPI Sleep State: Set whether to enable the sleep (S3) function, options: S3(Suspend to RAM), Suspend Disabled.
- I S3 Video Repost: Control to turn on or off the sleep graphics card self-test feature.

▶ Power Management Configuration

- | EUP: Control to turn on or off the motherboard power saving function (USB is not powered when turned on by default).
- | USB S4/S5 Power Support: Controls whether the USB port is powered when the host computer is in the hibernation and shutdown state, options: [disabled], [enabled].
- | Wakeup on USB: Controls whether or not the host can be woken up by the keyboard and mouse when it is in sleep state, options: [disabled], [enabled].
- | Wakeup on LAN: Control to turn the Wake on Network feature on or off, options: [disabled], [enabled].
- | Restore AC Power loss: Sets the state of the motherboard when it loses AC and then resumes powering up. Options: Power On (power back on), Power Off (no power on after power back on), Last State (back to pre-power off state).
- | Wakeup By RTC: Set the Wake Up Timer function. Options: Disabled, Enabled \RTC Alarm Date. Note: 0 for daily wakeup \<Hour><Minute><Second> for the specific time of wakeup

2.4 Turbo :

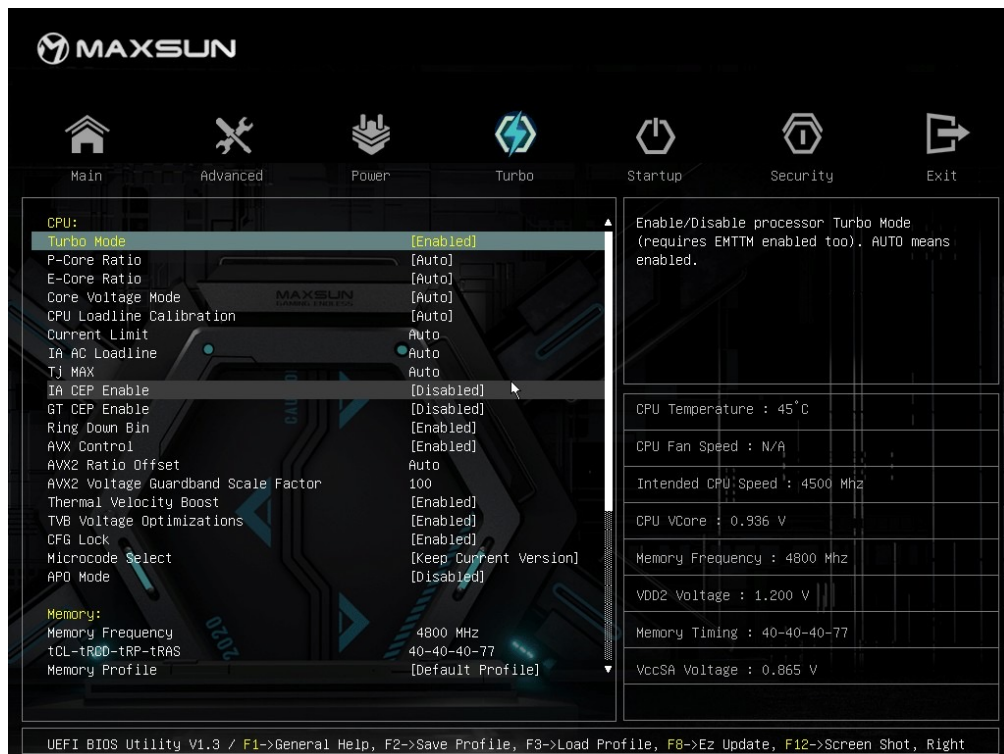



▶ Turbo Mode

Enables automatic overclocking of the CPU for increased performance under heavy workloads.

▶ P-Core Ratio

Adjusts the multiplier for the CPU's primary cores, allowing fine-tuning of their operating frequency.

▶ E-Core Ratio

Sets the multiplier for the CPU's efficiency cores, facilitating adjustment of their operating frequency.

▶ Core Voltage Mode

Determines the method for controlling CPU core voltage, providing options for manual or automatic adjustment.

▶ CPU Loadline Calibration

Compensates for voltage droop under load, ensuring stable power delivery to the CPU.

▶ Current Limit

Sets the maximum current allowed to pass through the CPU, regulating power consumption and heat output.

▶ **IA AC Loadline**

Adjusts the loadline calibration for the CPU's internal power delivery circuitry.

▶ **Tj MAX**

Defines the maximum allowable junction temperature for the CPU, helping to prevent overheating.

▶ **IA CEP Enable**

Enables or disables Current Estimation Prediction to improve power efficiency.

▶ **GT CEP Enable**

Activates Current Estimation Prediction for the CPU's integrated graphics.

▶ **Ring Down Bin**

Determines how many frequency bins to decrease when all CPU cores are idle.

▶ **AVX Control**

Manages CPU frequency adjustments when running AVX instructions to optimize stability.

▶ **Thermal Velocity Boost**

Automatically increases CPU frequency based on thermal conditions for enhanced performance.

▶ **TVB Voltage Optimizations**

Optimizes CPU voltage for Thermal Velocity Boost operation.

▶ **CFG Lock**

Locks or unlocks access to certain CPU configuration registers, affecting system behavior and performance.

▶ **Microcode Select**

Specifies which microcode version to use for CPU operation, influencing compatibility and performance.

▶ **APO Mode**

Sets the power-saving mode for the CPU, adjusting performance based on workload requirements.

▶ **Memory Profile**

Select to turn on memory XMP profile (XMP data is memory dependent).

▶ **Memory Frequency**

Setting memory frequency parameters (Auto/2100-5000MHz).

▶ **Gear Mode**

Setting the ratio mode of memory frequency to memory controller frequency (Auto/Gear1/Gear2).

▶ **Mem Ref Clock**

Controls the reference clock speed for memory modules, affecting memory stability and performance.

▶ **High Bandwidth Mode**

Enhances memory bandwidth by adjusting memory timing parameters.

▶ **Memory Timing**

Controls memory access timings for improved system stability and performance, allowing adjustment of memory latency parameters.

▶ **Memory Voltage VDDQ**

Setting memory voltage parameters (Auto/1.2-1.65V).

▶ **Memory Voltage VPP**

Setting memory activation voltage parameters (Auto/2.5V/2.8V).

▶ **VccSA Voltage Mode**

Determines the method for controlling the system agent voltage.

▶ **E-Core L2 Voltage Mode**

Specifies the voltage control method for the CPU's efficiency cores' L2 cache.

▶ **CPU 1.8V Voltage**

Sets the voltage level for certain CPU components.

▶ **CPU 1.05V Voltage**

Specifies the voltage for specific CPU components.

▶ **Power Limit 1**

Defines the maximum power consumption allowed by the CPU under different conditions.

▶ **Power Limit 1 Time**

Sets the duration for which Power Limit 1 can be sustained before throttling occurs.

▶ **Power Limit 2**

Defines the maximum power consumption allowed by the CPU under different conditions.

2.5 Startup:

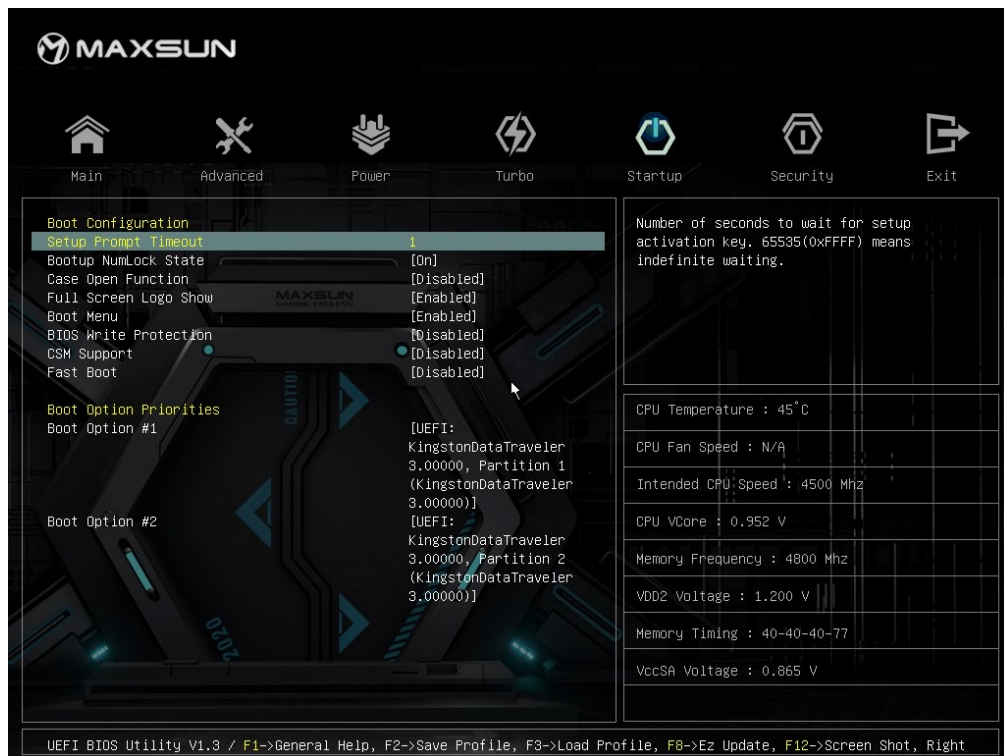

▶ Setup Prompt timeout

Setting the amount of time the motherboard stays at the LOGO when booting up.

▶ Bootup NumLock State

Setting the BIOS to enable or disable the keypad, options: [on], [off].

▶ Case Open Function

Determines system behavior when the computer case is opened, such as alerting the user or entering a specific mode.

▶ Full Screen Logo Show

Control to turn on or off the display of the boot logo, options: [disabled], [enabled].

▶ Boot Menu

Control to turn on or off the Guided Prompts menu, options: [disabled], [enabled].

▶ BIOS Write Protection

Set whether to enable the BIOS write protection function. This option must be turned off before updating the BIOS, options: [disabled], [enabled].

▶ CSM Support

Set the boot system for booting, Disabled (UEFI system), Enabled (manual selection). When CSM is turned on, the boot option filter options are UEFI and Legacy, UEFI only, Legacy only. Set whether to enable fast boot, options: [disabled], [enabled].

▶ Fast Boot

Accelerates system startup by bypassing certain hardware checks and initialization processes, reducing boot time for quicker system access.

▶ Boot Option Priorities

Sets the device that is selected for priority booting.

2.6 Security:



▶ Administrator password

Set the password to enter administrator mode. The BIOS options can be modified only after entering the administrator mode.

▶ User Password

Set the password for entering user mode. BIOS settings cannot be changed in user mode.

▶ Secure Boot

Set whether to enable secure boot.

2.7 Exit:



▶ Ez Update

Facilitates easy BIOS firmware updates via a user-friendly interface, simplifying the process of keeping system firmware up-to-date.

▶ Save Changes and Exit

Save current BIOS settings and exit.

▶ Discard Changes and Exit

Do not save the currently changed BIOS information and exit.

▶ Save Changes and Reset

Save current BIOS settings and reboot.

▶ Discard Changes and Reset

Not saving the currently changed BIOS options and rebooting.

 **Save Changes**

Save current BIOS settings.

 **Discard Changes**

Not saving current BIOS settings.

 **Load Optimal Defaults**

Restore default factory settings.

 **Save as User Defaults**

Save the current options as the user's default settings.

 **Restore User Defaults**

Restore the user's default settings. Note: You need to create the user default settings first.

 **Boot Override**

Displaying the boot.