



# DEEBOT PRO PLUS

**Instruction Manual**

# Important Safety Instructions

## IMPORTANT SAFETY INSTRUCTIONS

When using an electrical Appliance, basic precautions should always be followed, including the following:

### READ ALL INSTRUCTIONS BEFORE USING THIS APPLIANCE SAVE THESE INSTRUCTIONS

1. This Appliance can be used by children aged from 8 years and above and persons with reduced physical, sensory or mental capabilities or lack of experience and knowledge if they have been given supervision or instruction concerning use of the Appliance in a safe way and understand the hazards involved. Children shall not play with the Appliance. Cleaning and user maintenance shall not be made by children without supervision.
2. Clear the area to be cleaned. Remove power cords and small objects from the floor that could entangle the Appliance. Tuck rug fringe under the rug base, and lift items such as curtains and tablecloths off the floor.
3. If there is a drop off in the cleaning area due to a step or stairs, you should operate the Appliance to ensure that it can detect the step without falling over the edge. It may become necessary to place a physical barrier at the edge to keep the unit from falling. Make sure the physical barrier is not a trip hazard.
4. Only use as described in this manual. Only use attachments recommended or sold by the manufacturer.
5. Please make sure your power supply source voltage matches the power voltage marked on the Docking station.
6. For INDOOR household use ONLY. Do not use the Appliance in outdoor, commercial or industrial environments.
7. Use only the original rechargeable battery and Docking Station (Auto-Empty Station) provided with the Appliance from the manufacturer. Non-rechargeable batteries are prohibited.
8. Do not use without dust bin and/or filters in place.
9. Do not operate the Appliance in an area where there are lit candles or fragile objects.
10. Do not use in extremely hot or cold environments (below  $-5^{\circ}\text{C}/23^{\circ}\text{F}$  or above  $40^{\circ}\text{C}/104^{\circ}\text{F}$ ).
11. Keep hair, loose clothing, fingers, and all parts of body away from any openings and moving parts.
12. Do not operate the Appliance in a room where an infant or child is sleeping.
13. Do not use Appliance on wet surfaces or surfaces with standing water.
14. Do not allow the Appliance to pick up large objects like stones, large pieces of paper or any item that may clog the Appliance.
15. Do not use Appliance to pick up flammable or combustible materials such as gasoline, printer or copier toner, or use in areas where they may be present.
16. Do not use Appliance to pick up anything that is burning or smoking, such as cigarettes, matches, hot ashes, or anything that could cause a fire.
17. Do not put objects into the suction intake. Do not use if the suction intake is blocked. Keep the intake clear of dust, lint, hair, or anything that may reduce air flow.
18. Take care not to damage the power cord. Do not pull on or carry the Appliance or Docking station by the power cord, use the power cord as a handle, close a door on the power cord, or pull power cord around sharp edges or corners. Do not run Appliance over the power cord. Keep power cord away from hot surfaces.
19. If the power cord is damaged, it must be replaced by the manufacturer or its service agent in order to avoid a hazard.

20. Do not use the Docking station if it is damaged. The power supply is not to be repaired and not to be used any longer if it is damaged or defective.
21. Do not use with a damaged power cord or receptacle. Do not use the Appliance or Docking station if it is not working properly, has been dropped, damaged, left outdoors, or come in contact with water. It must be repaired by the manufacturer or its service agent in order to avoid a hazard.
22. Turn OFF the power switch before cleaning or maintaining the Appliance.
23. The plug must be removed from the receptacle before cleaning or maintaining the Docking station.
24. Remove the Appliance from the Docking station, and turn OFF the power switch to the Appliance before removing the battery for disposal of the Appliance.
25. The battery must be removed and discarded according to local laws and regulations before disposal of the Appliance.
26. Please dispose of used batteries according to local laws and regulations.
27. Do not incinerate the Appliance even if it is severely damaged. The batteries can explode in a fire.
28. When not using the Docking station for a long period of time, please unplug it.
29. The Appliance must be used in accordance with the directions in this Instruction Manual. Ecovacs Robotics Co., Ltd. cannot be held liable or responsible for any damages or injuries caused by improper use.
30. The Robot contains batteries that are only replaceable by skilled persons. To replace the Robot's battery, please contact Customer Service.
31. If the Robot will not be used for a long time, power OFF the Robot for storage and unplug the Docking station.
32. **WARNING:** For the purposes of recharging the battery, only use the detachable supply unit CH2319 provided with the Appliance.

The lithium battery type suitable for CH2319 is Max. 8 cells, max. nominal voltage DC14.4V, rated capacity 4,800mAh. The battery must be removed and discarded according to local laws and regulations before disposal of the Appliance.











To satisfy RF exposure requirements, a separation distance of 20 cm or more should be maintained between this device and persons during device operation.

To ensure compliance, operations at closer than this distance is not recommended. The antenna used for this transmitter must not be co-located in conjunction with any other antenna or transmitter.

### **Device Update**

Typically, some devices are updated bi-monthly, but not always so specific.

Some devices, especially those that went on sale more than three years ago, will only be updated if a critical vulnerability is found and fixed.

	Short-circuit-proof safety isolating transformer.
	Switch mode power supply.
	For indoor use only.
	Direct current.
	Alternating current.
	This product conforms to the applicable EC Directives.
	Before charging, read the instructions.
	This product conforms to the applicable UK legislation.
	Polarity of the charging port.
	Time-lag miniature fuse-link.
	Class II equipment.

## For EU Countries

For EU Declaration of Conformity information, visit <https://www.ecovacs.com/global/compliance>.

## For UK

For UK Declaration of Conformity information, visit <https://www.ecovacs.com/global/compliance>.



## Correct Disposal of this Product

This marking indicates that this product should not be disposed of with other household waste throughout the EU. To prevent possible harm to the environment or human health from uncontrolled waste disposal, recycle it responsibly to promote the sustainable reuse of material resources. To recycle your used device, please use the return and collection systems or contact the retailer where the product was purchased. They can safely recycle this product. The remote surveillance is for the absolute private use of non-public, private owned places for the pure selfprotection and single control intended only. Please be aware of the local data protection based legal obligations in case of use. No surveillance of public places, especially with clandestine intent and/or on the part of the employer without justified reasons. Such not justified use is in the risk and responsibility of the user only.

## European Union Compliance Statement

### Information on Disposal for Users of Waste Electrical & Electronic Equipment



This symbol on the product or on its packaging indicates that used electrical and electronic products should not be mixed with unsorted municipal waste. For proper treatment, it is your responsibility to dispose of your waste equipment by arranging to return it to designated collection points.

Disposing of this product correctly will help save valuable resources and prevent any potential negative effects on human health and the environment, which could otherwise arise from inappropriate waste handling.

To return your used device, please use the return and collection systems or contact the retailer where the product was purchased, which is free of charge, please contact your local authority for further details of your nearest designated collection point. Penalties may be applicable for incorrect disposal of this waste, in accordance with your national legislation.

### Information on Disposal for Users of used Batteries



This symbol means that batteries and accumulators, at their end-of-life, should not be mixed with unsorted municipal waste. Your participation is an important part of the effort to minimize the impact of batteries and accumulators on the environment and on human health.

For proper recycling you can return this product or the batteries or accumulators it contains to your supplier or to a designated collection point, which is free of charge.

Disposing of this product correctly will help save valuable resources and prevent any potential negative effects on human health and the environment, which could otherwise arise from inappropriate waste handling.

Penalties may be applicable for incorrect disposal of this waste, in accordance with your national legislation. There are separate collection systems for used batteries and accumulators.

Please, dispose of batteries and accumulators correctly at your local community waste collection/recycling center.

## **Restriction of the use of certain hazardous substances (RoHS) Directive**

Ecovacs Robotics Co., Ltd. Hereby declares the whole product including parts (cables, cords, and so on) meets the requirements of RoHS Directive 2011/65/EU and amendment Commission Delegated Directive (EU) 2015/863 on the restriction of the use of certain hazardous substances in electrical and electronic equipment ("RoHS recast" or "RoHS 2.0").

## **Radio Equipment Directive**

Ecovacs Robotics Co., Ltd. Hereby declares that the product listed in this section comply with the essential requirements and other relevant provisions of the Radio Equipment Directive 2014/53/EU.

## **Europe Authorised Representative:**



ECOVACS Europe GmbH  
Holzstrasse 2 | D-40221 Düsseldorf | Germany

Ecovacs Robotics Co., Ltd. Hereby declares that the product comply with the essential requirements and other relevant provisions of the RoHS Directive 2011/65/EU and amendment Commission Delegated Directive (EU) 2015/863, the Radio Equipment Directive 2014/53/EU. The declaration of conformity can be viewed at the following address: <https://www.ecovacs.com/global/compliance>.

# 1. Package Contents

## 1.1 Package Content

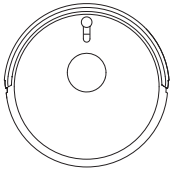

Robot

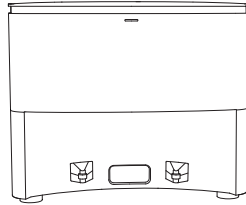

Auto-Empty Station



Washable Mopping Pad

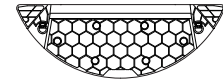

Mopping Pad Plate

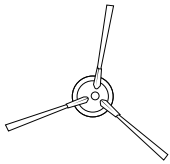

Side Brush

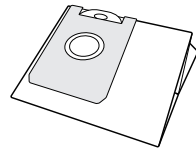

Dust Bag



Instruction Manual



Screw Bag

**Note:** Figures and illustrations are for reference only and may differ from actual product appearance. Product design and specifications are subject to changes without notice.

## 1.2 Product Diagram

### Robot

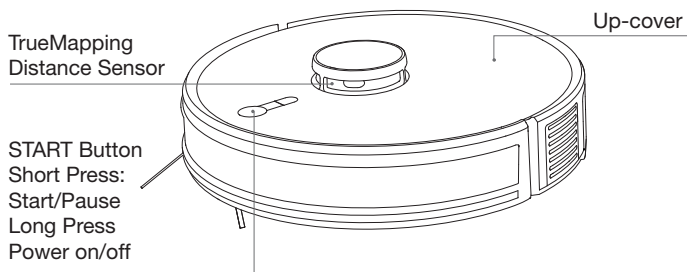

Charging Button:  
Short Press: Go To Charge  
Long Press: Reset

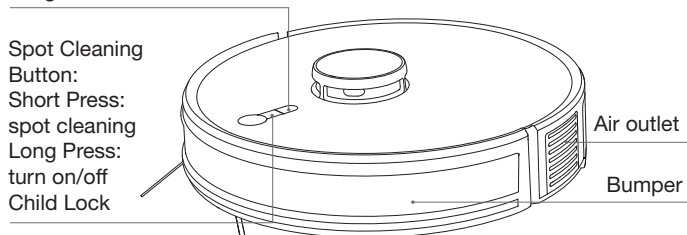

- In Child Lock mode, buttons and smart speakers are disabled, preventing potential dangers from accidental operations by children.
- Restore to factory settings: Long press the charging Button for 10-15s.

### 2 in 1 Module

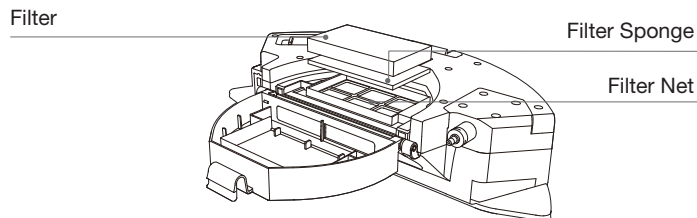
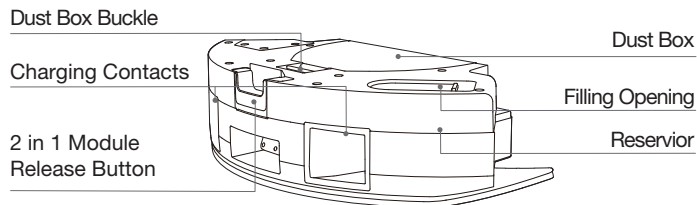

### Mopping Pad Module

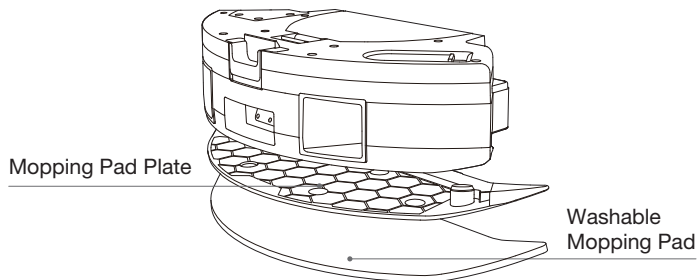

## Bottom View

Anti-drop Sensors

Universal Wheel

Anti-drop Sensors

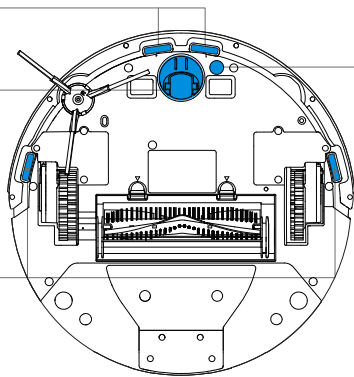

Carpet Detection Sensor

Main Brush Release Button

Driving Wheels

Installation Port for Mopping Pad Module

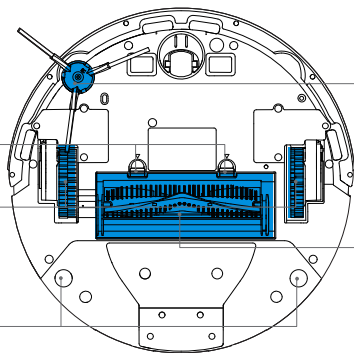

Side Brush

Main Brush

## Auto-Empty Station (AES)

Top Cover

Dust Bag

LED Indicator

Charging Contacts

Dust Bag Opening

Dust Collection Port

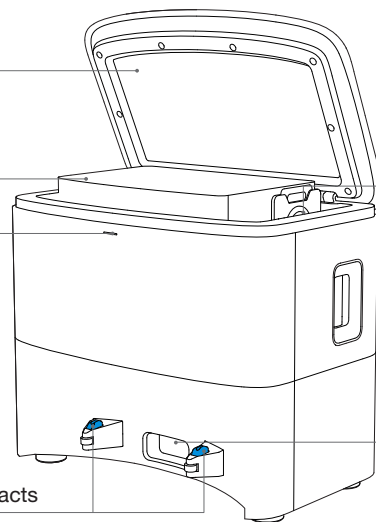

### 1.3 TrueMapping Distance Sensor

Name	Functional Description
TrueMapping Distance Sensor	With Laser Ranging-measuring the distance between Robot and surroundings through the time difference of reflection, it can map according to the objects around while Robot is moving. Detection of 8m.
Anti-drop Sensor	With Infrared Ranging detecting the distance between the bottom of Robot and ground by Infrared Sensor at the bottom, Robot will not move forward when there are stairs in front (For example: White ground height greater than 30mm.) or the identified distance exceeds the preset one, realizing the Anti-drop.
Carpet Detection Sensor	The ultrasound probe can emit ultrasonic waves with a frequency of 300KHZ. The energy of the ultrasonic waves is absorbed by the carpet. If the reflected energy is below the threshold, the Robot recognizes the presence of the carpet.
Anti-collision Sensor	When the transmitted signal is blocked by an obstacle, the signal receiver will not be able to receive the signal. With this principle, the device will avoid obstacles when colliding with them.

## 2. Operations

### 2.1 Notes Before Cleaning

Tidy up the area to be cleaned by putting furniture, such as chairs, in their proper place.

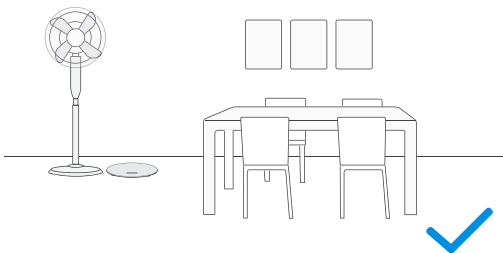

It may be necessary to place a physical barrier at the edge of a drop to stop the unit from falling over the edge.

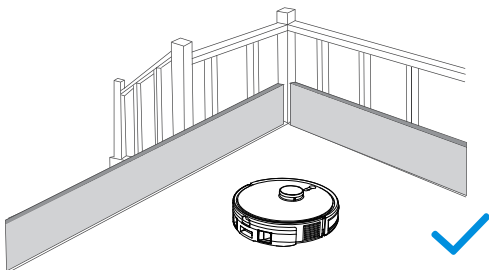

During the first use, make sure each room door is open to help Robot fully explore your house.

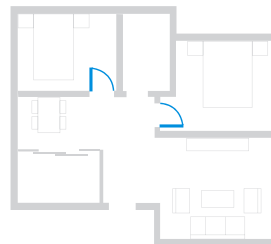

Put away objects including cables, cloths and slippers, etc. on the floor to improve the cleaning efficiency.



Before using the product on a rug with tasseled edges, please fold the rug edges under.



Please do not stand in narrow spaces, such as hallways, and make sure not to block the camera.

## 2.2 Quick Start

\* Before using the product, please remove all protective materials.

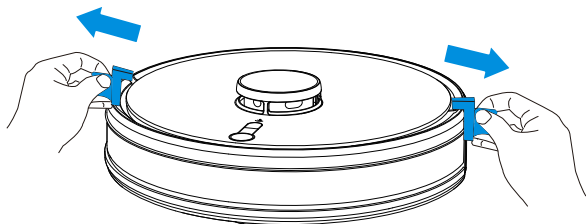

\* Before using the product, please take the screwdriver and screws out of the screw pack for installation.

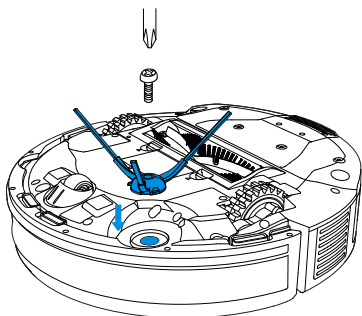

## 2.3 Download and Connect ECOVACS HOME App

To enjoy all available features, it is recommended to control your Robot via the ECOVACS HOME App.

**Method 1:** Scan the QR code on the Robot or Instruction Manual to download the App.

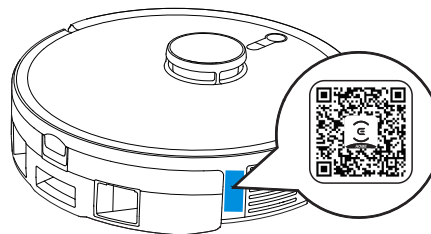

**Method 2:** Search the ECOVACS HOME to download the App.



## Connect Robot with App via Wi-Fi.

Note:

1. Robot should be fully charged and turned on.
2. Wi-Fi indicator is on.
3. Turn off the mobile network.

Wi-Fi Network Requirements:

- You are using a 2.4GHz or 2.4/5 GHz mixed network.
- Your router supports 802.11b/g/n and IPv4 protocol.
- Do not use a VPN (Virtual Private Network) or Proxy Server.
- Do not use a hidden network.
- WPA and WPA2 using TKIP, PSK, AES/CCMP encryption.
- WEP EAP (Enterprise Authentication Protocol) is not supported.
- Use Wi-Fi channels 1-11 in North America and channels 1-13 outside North America (refer to local regulatory agency).
- If you are using a network extender/repeater, the network name (SSID) and password are the same as your primary network.
- Please enable the WPA2 on your router.

Please be aware that the realization of intelligent functions such as remote startup, voice interaction, 2D/3D map display and control settings, and personalized cleaning (depending on different products) requires users to download and use ECOVACS HOME App, which is constantly updated. You need to agree to our Privacy Policy and User Agreement before we can process some of your basic and necessary information and enable you to operate the product. If you do not agree with our Privacy Policy and User Agreement, some of the aforementioned intelligent functions cannot be realized through ECOVACS HOME App, but you can still use the basic functions of this product for manual operation.

## 2.4 Charging Robot

### 1 Connect the Power Cord.

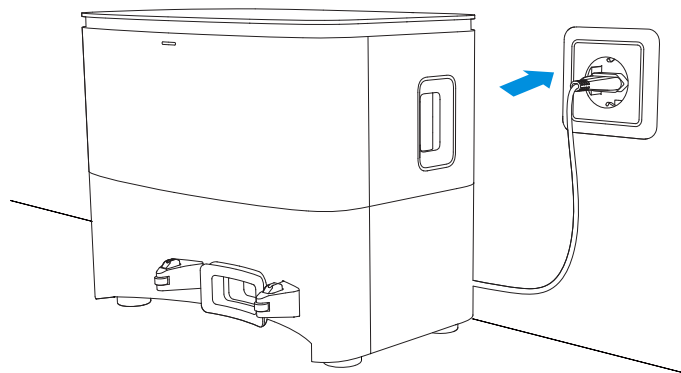

## 2 Place the Auto-Empty Station

The Auto-Empty Station should be placed against a wall on a flat ground, and no items should be placed with in a range of (0.5m to left and right sides) and (1.5m to the front).

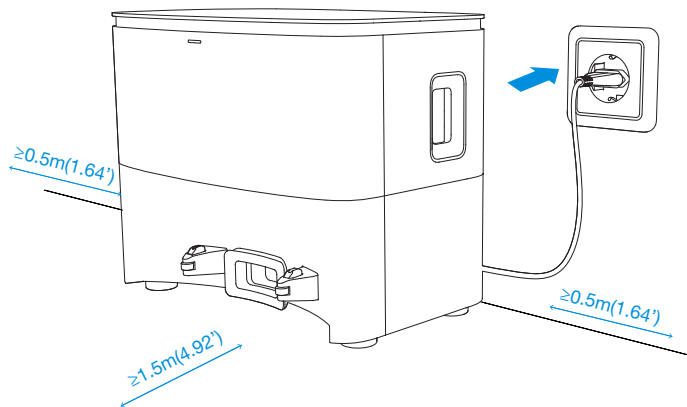

## 3 Power ON

Long press the START Button for 3 seconds to turn on the Robot.

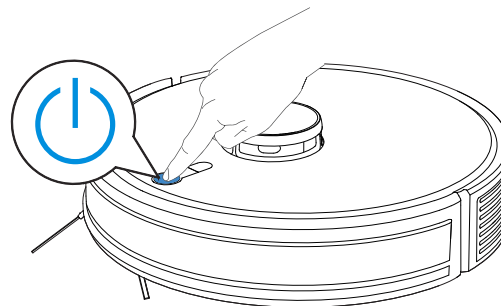

\* It is recommended to place the Station on the hard floor to experience complete functions of the Robot.

## 4 Charging

Short press the Charging button to make Robot return for charging.

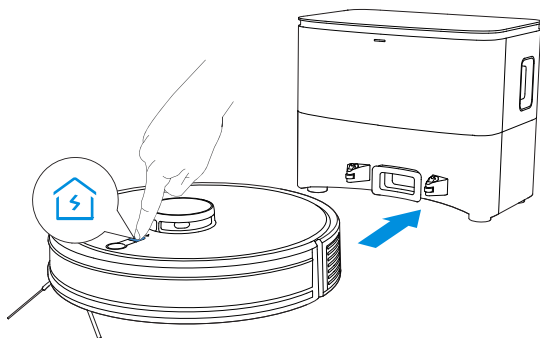

\* It is recommended that Robot start cleaning from the Station.  
Do not move the Station while cleaning.

## 2.5 Start Cleaning

### 1 Create a map

When creating a map for the first time, please follow Robot to help eliminate some minor issues. For example, the Robot may get stuck under low furniture. Take following solutions for reference. Solve the issue as below.

- ① Lift up the furniture if possible.
- ② Cover the bottom of the furniture, to prevent Robot from entering.
- ③ Set up Virtual Boundary via the App to prevent the Robot from entering.

### 2 Start Cleaning

Before first vacuuming, please make sure the Robot is in the Auto-Empty Station and fully charged. Short press  to start cleaning and create a map at the same time.

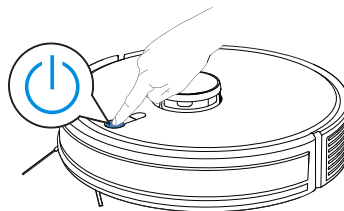

### 3 Pause

When Robot is working, short press  to pause.

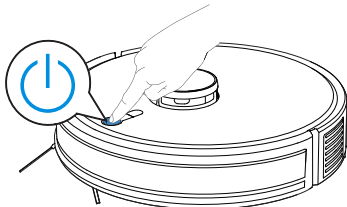

### 4 Wake up

The indicator light will go out after the Robot is paused for a few minutes. Short press  to wake it up.

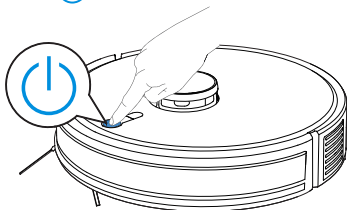

### 5 Spot Cleaning

Short press  key, it will clean the area 1.5\*1.5m with its position as center.

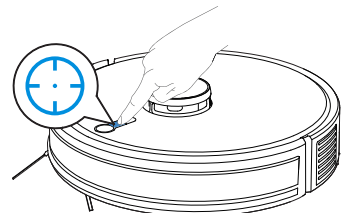

### 6 Dust collection

The Robot will automatically return to the Auto-Empty Station to collect dust.

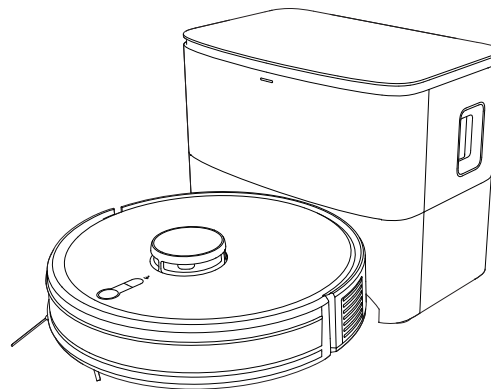

## 2.6 Start moping

### 1 Add Water

Take out the 2 in 1 Module, open the Filling Opening and add water.

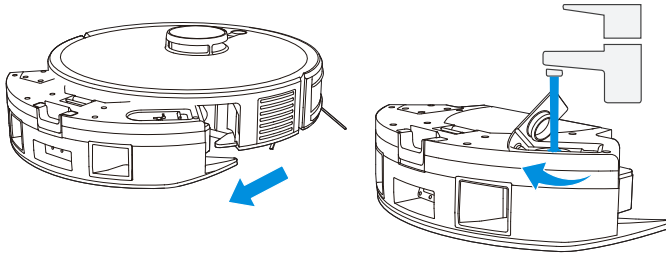

### 2 Install Mopping Pad and Mopping Pad Module

Stick the white side of the Mopping Pad onto the velcro of the Mopping Pad Plate. Insert the protruded part of the Mopping Pad Plate into the installation port. The sound of Click indicates proper installation.

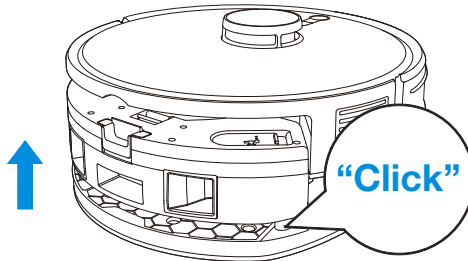

### 3 Start mopping

Short press  to start mopping.

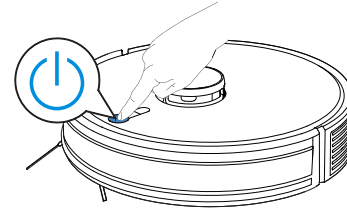

#### Notes:

Do not frequently remove Washable Mopping Pad.  
Do not use a rag or any other object to scratch the Moping Pad Plate.  
Please empty the reservoir after Robot finishes mopping.

## 3. Maintenance

### 3.1 Maintenance frequency

To keep Robot running at peak performance, perform maintenance tasks and replace parts with the following frequencies:

Part	Maintenance frequency	Replacement frequency
Washable Mopping Pad	every cleaning	every 1-2 months
Dust Bag	/	follow APP remind
Side Brush	every 2 weeks	every 3-6 months
Main Brush	every week	every 6-12 months
Filter	every week	every 3-6 months
TrueMapping Distance Sensor Universal Wheel Anti-drop Sensor Bumper Robot's Charging Contacts Auto-Empty Station Charging Contacts	every week	/
Auto-Empty Station	every week	/

**Warm note:** If you want to buy accessories, please visit ECOVACS HOME App store or: <https://www.ecovacs.com/global>

## 3.2 Maintain Dust Box

1

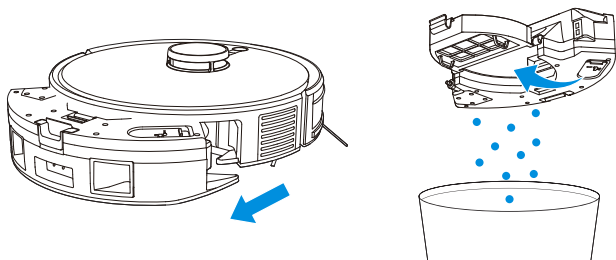

2

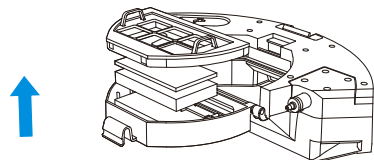

3

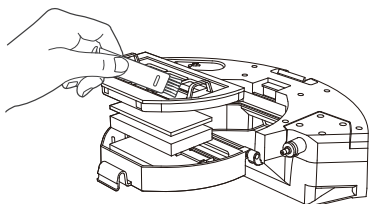

4

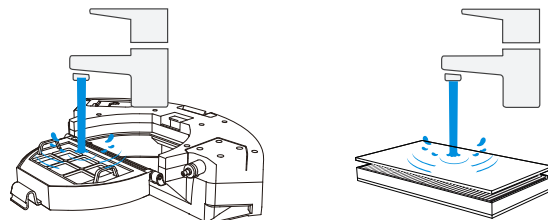

**Note:**

Do not use finger or brush to clean the filter.

5

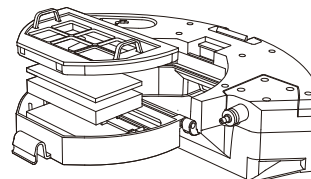

**Note:** Completely dry the filter before use.

Explore more accessories at ECOVACS HOME App or at <https://www.ecovacs.com/global>

### 3.3 Maintain Main Brush and Side Brush

#### Main Brush

1

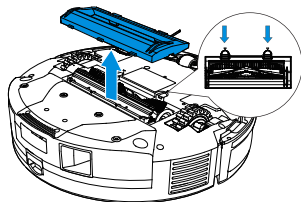

2

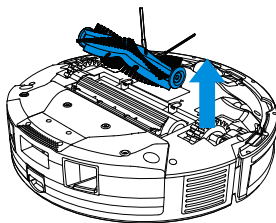

3

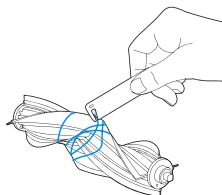

#### Side Brush

1

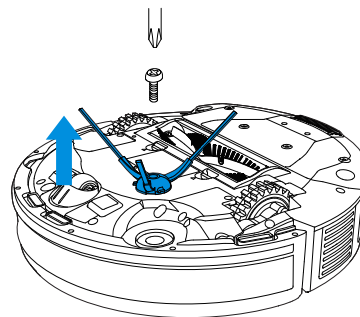

2

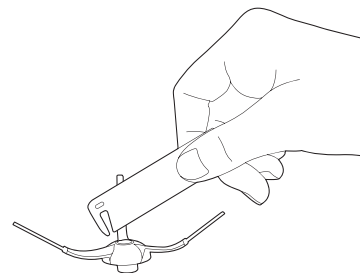

### 3.4 Maintain Other Parts

#### Bumper

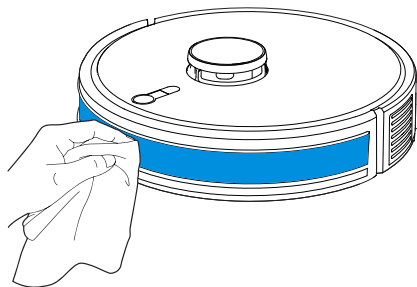

#### TrueMapping Distance Sensor

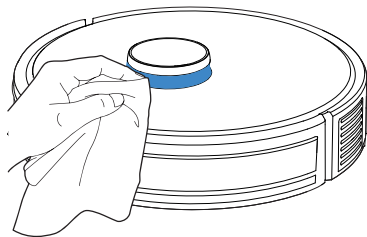

**Note:** Wipe the components with a clean, dry cloth. Avoid using cleaning sprays or detergents.

#### Anti-drop Sensor

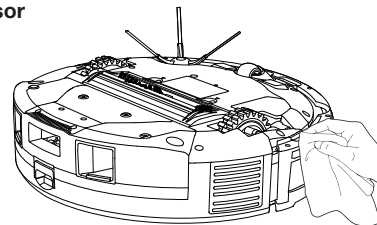

#### Charging Contacts

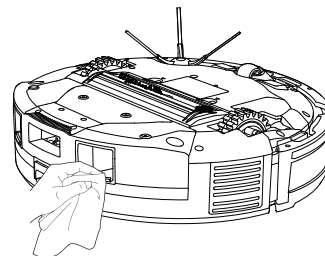

#### Wheels

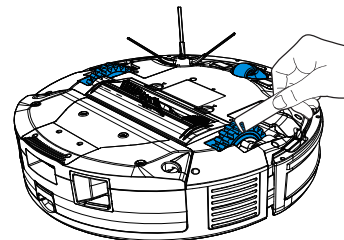

**Note:** Do not clean Charging Contacts with wet cloths.

### 3.5 Maintain Dust Bag

1

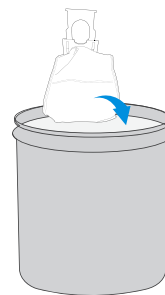
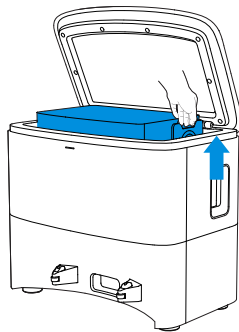
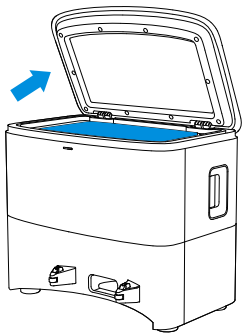

\* Hold the Handle to lift out the Dust Bag, which can effectively prevent dust leakage.

2

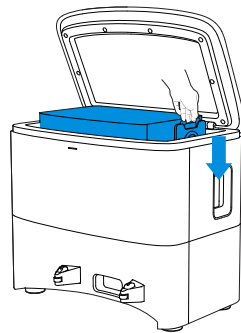

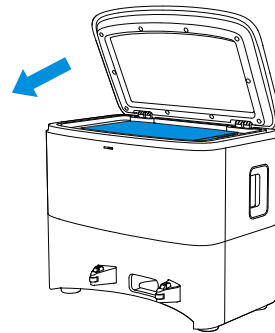

3

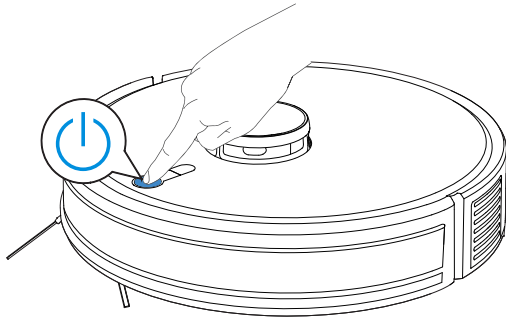

### 3.6 Storage

Long press  for 5 seconds to power off the Robot.  
Please fully charge and switch OFF the Robot before storage.  
Please recharge it every 1.5 months to prevent the battery from over-discharge.



 Robot can't be charged when the power is turned off.

\* If the battery is over-discharged or not used for a long time, the Robot may not be charged. Please contact ECOVACS for help.  
Do not disassemble by yourself.

## 4. Troubleshooting

NO.	Issues	Possible Causes	Solutions
1	Robot can't connect to APP.	The router user name and password are incorrect.	Configure the router network and make sure that the "user name" and "password" of the router are correct.
		The Robot is not within the network signal coverage of the router.	Ensure the Robot is within the network signal coverage of the router.
		Robot is not in the configuration state.	Make sure Robot is connected to the power supply and turned on. Press Charging Button and Spot Cleaning Button at the same time for 3 seconds. Robot will enter the configuration state when you hear a voice prompt.
		Not use 2.4GHz or 2.4/5GHz network.	The Robot doesn't support 5G network at present. Please choose 2.4GHz or 2.4/5GHz.
		Download the wrong APP.	Please scan the code or download the ECOVACS HOME App in store.
2	Map lost.	It is possible to lose the map if move the Robot manually.	Try to recover by moving the Robot into Auto-Empty Station. Find the stored map in APP map storage, and press "use map" to recover. If this problem persists after trying the above solutions, please restart mapping.
3	Can't creat maps in APP.	The Robot doesn't start working from Auto-Empty Station.	The Robot must start cleaning from Auto-Empty Station.
		Cleaning is not finished.	Allow the Robot return to Auto-Empty Station when it finishes the cleaning.
4	Unable to return to Auto-Empty Station.	The position of Auto-Empty Station is incorrect.	Please place the Auto-Empty Station correctly according to the chapter "Charging Robot" in user manual.

NO.	Issues	Possible Causes	Solutions
		Auto-Empty Station is powered off or moved by people.	Please ensure the Auto-Empty Station is powered on, and don't move Auto-Empty Station.
		The Robot doesn't start working from the the Auto-Empty Station.	It is recommended that Robot start cleaning from the Auto-Empty Station.
		The charging route is blocked. For example, the door of the room with the Auto-Empty Station is closed.	Keep the charging route clear.
5	Robot returns to the Auto-Empty Station before it has finished cleaning.	The room is so large that Robot needs to return to recharge.	Please enable Continuous Cleaning. For more details, please follow the App instruction.
		Robot is unable to reach certain areas blocked by furniture or barriers.	Tidy up the area to be cleaned by putting furniture and small objects in their proper place.
6	Robot is unable to charge.	Auto-Empty Station is not connected to power supply.	Ensure Auto-Empty Station is connected to power and the indicator is on.
		Robot's Charging Contacts are not connected to the Auto-Empty Station Charging Contacts.	Make sure that the Robot's Charging Contacts have connected to the Auto-Empty Station Charging Contacts and "START Button" flashes. Check whether Robot's Charging Contacts and Auto-Empty Station Charging Contacts are dirty. Please clean these parts according to the instructions in the chart "Maintenance".
		Battery temperature is too high or too low.	Please charge and operate the Robot in the temperature between 0-40 degree.
		Extended periods of non-use may lead to over-discharge of the battery.	We recommend using the product regularly. If extended periods of non-use result in charging issues, please contact customer service for assistance.
7	Abnormal noise during cleaning.	Side brush and Main Brush are entangled. Dust Box and filter are blocked.	It is recommended to clean the side brush, main box, dust box, filter, etc. regularly.
		The Robot is in max mode.	Change to standard mode.

NO.	Issues	Possible Causes	Solutions
8	Robot gets stuck while working and stops.	Robot is tangled with something on the floor (electrical wires, curtains, carpet fringing, etc.).	Robot will try various ways to free itself. If it is unsuccessful, manually remove the obstacles and restart.
		Robot might be stuck under furniture with an entrance of similar height.	Please set a physical barrier, or set a Virtual Boundary in the ECOVACS HOME App.
9	The following problems appear when Robot is working: disordered cleaning route, deviation from the cleaning route, repeated cleaning, or missing of small areas to be cleaned. (If there is a large area that has not been cleaned temporarily, Robot will automatically clean the missing area.)	The wires, slippers and other objects placed on the ground affect the normal work of the Robot.	Please tidy up the scattered objects on the ground such as wires, slippers before cleaning. If there is any area missing, Robot will clean the missing area by itself, please do not interfere (such as moving Robot or blocking the route).
		When the Robot climbs the steps, threshold and door strip, the driving wheel slipped with the ground, which will affect Robot's judgment on the environment of the whole house.	It is recommended to close the door of the area and clean the area separately. After cleaning, it will return to the starting point. Please rest assured to use it.
		Work on freshly waxed and polished floors or smooth tiles, resulting in less friction between the Driving Wheels and the floor.	It is recommended that you wait for the floor wax to dry before using.
		Due to the different house environment, the Robot can not enter some areas.	It is suggested to tidy up the home environment to ensure that the Robot can enter for cleaning.
		The TrueMapping Distance Sensor is dirty or covered.	Clean the TrueMapping Distance Sensor or uncover the objects on it.

NO.	Issues	Possible Causes	Solutions
10	The Auto-Empty Station can't collect dust when Robot returns.	Auto-Empty Station cover is open.	Close the Auto-Empty Station cover.
		Dust Bag is uninstalled.	Install dust bag and close the Auto-Empty Station cover.
		Robot is manually moved to Auto-Empty Station and Auto-Empty is not triggered.	Let the Robot returns to Auto-Empty Station automatically, don't move it manually.
		If "Do Not Disturb" mode is activated in ECOVACS HOME App, Auto-Empty Station does not collect dust automatically when the Robot returns.	Cancel the "Do Not Disturb" mode in ECOVACS HOME App, or start the dust collection manually.
		Auto-Empty Station detects that the dust collection efficiency is low.	Replace the dust bag according to "Maintenance" in user manual, and close the Auto-Empty Station cover. If App reminds that the dust bag is not full, reinstall it.
		If the above possible reasons have been ruled out, there may be an abnormality in the components of the Auto-Empty Station.	Please contact after-sales service.
11	Dust Collection failed.	Auto-Empty Station detects that the dust collection efficiency is low.	Replace the dust bag according to "Maintenance" in user manual, and close Auto-Empty Station cover. If App remind that the dust bag not full, reinstall it.
		The outlet of dust box is blocked.	Take out the 2 in 1 Module, and clean the dust box outlet.
12	The inner side of Auto-Empty Station is dirty.	Fine particles penetrates the dust bag and sticks on the inner side of the Auto-Empty Station.	Clean the inner side of the Auto-Empty Station.
		The dust bag is broken.	Replace the dust bag.

NO.	Issues	Possible Causes	Solutions
13	Dust leakage occurs during working.	The outlet of Dust Box is blocked.	Take out the 2 in 1 Module, and clean the Dust Box outlet.
14	Robot reservoir drops out of place during use.	The reservoir is not correctly installed.	Make sure Robot reservoir clicks into place when installing.
15	Driving wheels are blocked.	Driving wheels are blocked by foreign objects.	Please rotate and press the driving wheels to check whether there is any foreign object wrapped or stuck. If there is any foreign object, please clean it in time. If this problem persists, please contact Customer Care for help.
16	Robot does not perform Continuous Cleaning.	The Robot is in Do Not Disturb mode.	In Do Not Disturb mode, Robot does not perform Continuous Cleaning.
		The Robot did not automatically return to the Auto-Empty Station last time.	Continuous Cleaning is not performed when you manually recharge Robot or move it to Auto-Empty Station.
17	Robot does not clean automatically at the scheduled time.	Time Scheduling function is cancelled.	Reset appointment.
		The Robot is out of power.	Charge the Robot.
		The Robot is in Do Not Disturb mode.	In Do Not Disturb mode, Robot does not perform scheduled cleaning.

If you cannot solve the issues by following the above instructions, please contact after-sales service.

## 5. TECHNICAL SPECIFICATIONS

<b>Model</b>	<b>DLX32</b>
Rated input	20V === 1.2A
Charging time	4-5 hours
<b>Docking Station</b>	<b>CH2319</b>
Rated input	220-240V ~ 50-60Hz, 0.6A Max
Rated output	20V === 1.2A
Power Dust Collection	850W
Laser Lidar	5V=== 200 mA 940 nm

Output power of the Wi-Fi module is less than 100mW.

**Note:** Technical and design specifications may be changed for continuous product improvement.  
Explore more accessories at <https://www.ecovacs.com/global>.

**Ecovacs Robotics Co.,Ltd.**

No.518 Songwei Road, Wusongjiang Industry Park, Guoxiang Street,  
Wuzhong District, Suzhou, Jiangsu, China.