

Safe instructions

Before using this product, read the following safety instructions and follow all routine safety precautions. Please read this manual carefully and keep it well. Any operation inconsistent with this specification may cause damage to this product.

Caution:

- Only the authorized technicians can dismantle the product, and the user shall not dismantle it by himself.
- Please use the product according to the instructions. The product can only use the charging equipment and other accessories equipped by the manufacturer. Using other charging equipment and accessories may cause damage to the product.
- The possible problems in the product cleaning should be eliminated as soon as possible. Before using this product, remove all vulnerable items on the ground (such as glasses, lamps, etc.) and possible items (such as wires, paper, curtains) surrounding the product.
- Do not place the product in a place that is easy to fall off (such as on tables and chairs).
- If there is a suspended environment such as stairs, a fence should be installed at the edge of the suspended area to prevent the product from falling. And shall ensure that the protective facility does not cause personal injury such as tripping.
- Do not touch electrical wires, sockets, or power adapters when your hands are wet.
- Ensure that the dust box and filter material are installed in place before using the product.
- To prevent tripping, please inform the other members of the house.
- Before cleaning and maintaining the product, turn off the product and unplug from the power outlet.
- If the product is not used for a long time, please power off the product.
- Please dispose of the waste batteries in accordance with the local laws and regulations.
- Do not play with the product as a toy, and stay away from children or mentally handicapped people when operating.
- Do not use the product in the infant bedroom.
- This product is an indoor household product, do not be used in outdoor, commercial and industrial places.
- Do not use this product in a wet or waterlogged environment (such as a bathroom).
- Do not charge the product using a damaged power cord or power outlet. Do not use the product when it cannot work properly due to fall, damage, outdoor use or water intake. To avoid harm, the product should be repaired by the manufacturer or its after-sales service provider.
- Please use the product as indicated in the instructions. The Company shall not be liable for any loss and injury caused by improper use.

Warning:

- Prohibited to use product in environments with open flame or fragile items.
- Do not use or store products in extremely hot (above 40 C) or extremely cold (below 0 C) environments.
- Prohibited to use product to suck large items such as stones or large waste paper that may jeopardize the performance of the product.
- It is forbidden to put your arms or legs or pets near the product when operating to avoid injury.
- Do not suck any flammable items, such as gasoline, printer or photocopies. No use of products in clean areas with flammable items.
- Do not allow products to suck any burning items, such as cigarettes, matches, ashes and other items that may cause fire.
- Do not place items at the suction entrance. Do not use the product when the suction entrance is blocked. Clean up the dust, cotton wool, hair and so on at the suction entrance to ensure proper air circulation.
- Use the power cord carefully to avoid its damage. It is forbidden to use the power cord to drag or pull the products and charging equipment, use the power cord as a handle, clamp the power cord in the door, or pull the power cord at the corner. Prevent the products from running on the power cord, which should be kept away from the heat source.
- Prohibited to use any damaged charging equipment.
- The incineration of product is banned even when the product has been severely damaged. Battery of product could cause an explosion.

Battery safety

- Users are not allowed to replace the lithium battery in the machine at will. If the battery needs to replace or discard the battery, please do not discard it together with the household garbage. Please contact the after-sales department for disposal.
- Please remove the battery from the machine before the product is scrapped.
- When the battery is removed, ensure that the product is not powered on.
- Please recycle the waste battery safely.

Remove the battery step

- Running the robotic vacuum cleaner, till battery is emptying out
- Remove the product's battery cover screws.
- Remove the battery cover plate.
- Pull out the connector plug of the battery and remove the battery.

Laser safety

- The laser ranging sensor of this product meets the standard of Class 1 laser products of IEC60825-1:2014 and will not produce any dangerous laser radiation.

Safety Instructions:

- 1.This appliance can be used by children aged from 8 years and above and persons with reduced physical, sensory or mental capabilities or lack of experience and knowledge if they have been given supervision or instruction concerning use of the appliance in a safe way and understand the hazards involved.
- 2.Children shall not play with the appliance.
- 3.Cleaning and user maintenance shall not be made by children without supervision.
- 4.The plug must be removed from the socket-outlet before cleaning or maintaining the appliance.
- 5.CAUTION: In order to avoid a hazard due to inadvertent resetting of the thermal cut-out, this appliance must not be supplied through an external switching device, such as a timer, or connected to a circuit that is regularly switched on and off by the utility.
- 6.The self empty station can't recharging non-rechargeable batteries.
- 7.This appliance contains batteries that are only replaceable by skilled persons.
- 8.WARNING: For the purposes of recharging the battery, only use the self empty station (model: S100) provided with this appliance.
- 9.Laser class IEC-60825 Class 1.
- 10.The maximum laser output power of the product 10mW.
- 11.Laser head Pulse time 125us .
- 12.Invisible laser radiation.
- 13.Laser energy-Exposure near aperture may cay cause burns.
- 14.Standard:IEC 60825-1:2014.
- 15.Instructions are available at www.freedynamics.com.



For indoor use



Before charging, read the instructions

Contents

Product presentation	1
Product use	3
Parts maintenance	10
Regular maintenance	11
Common questions	14
Product parameter	15

Product presentation

List of accessories

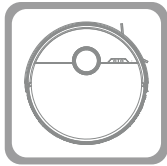

Robotic vacuum cleaner



Dust collector

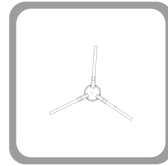

1x side brush

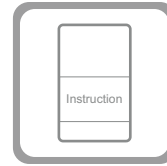

Product manual



cleaning brush

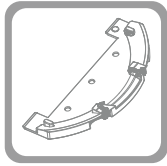

Mop bracket assembly

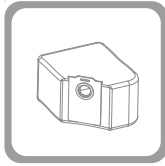

Dust bag(optional)

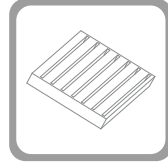

Hepa

! The specification diagram is for reference only, please refer to the actual product.

Product presentation

Robotic vacuum cleaner

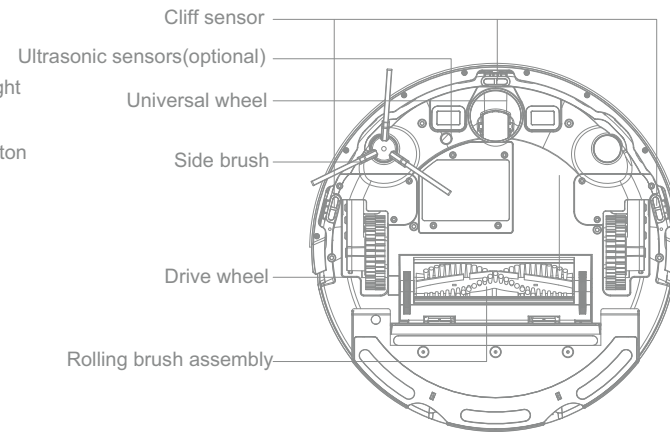
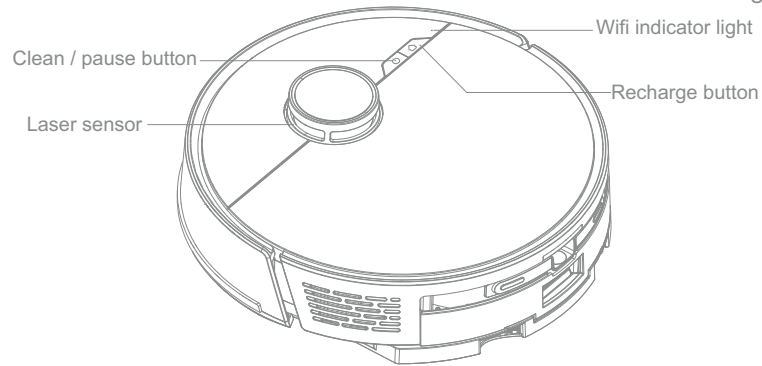

Dust box tank

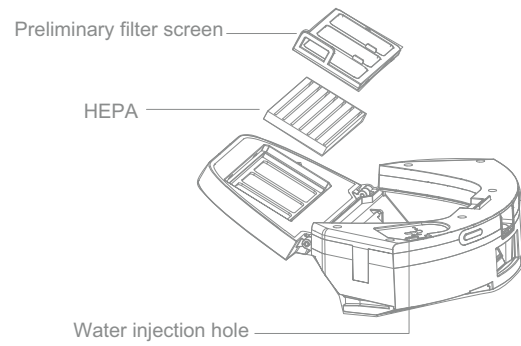

Dust collector

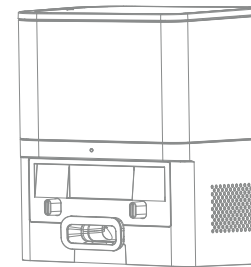

Product use

 Pay attention to

1. Please clean up the scattered wire and debris on the ground before starting, and remove the easy to pour, fragile, valuable and dangerous items, so as to avoid winding, stuck, dragging or knocking down the personal or property damage caused by the robotic vacuum cleaner.
2. Please avoid using this product in the wading area, otherwise it will damage the fan and affect the machine performance.
3. It is strictly prohibited to use this product in high places without guardrail.

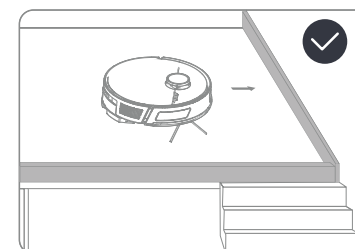
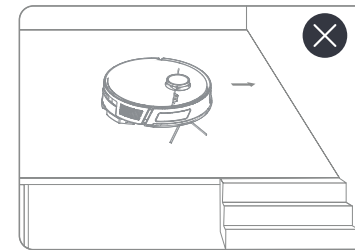
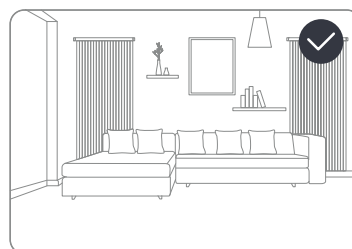
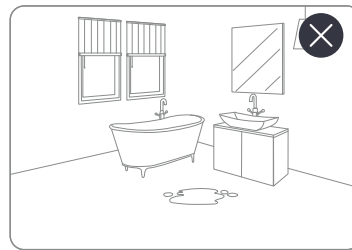
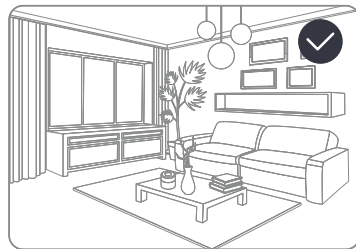
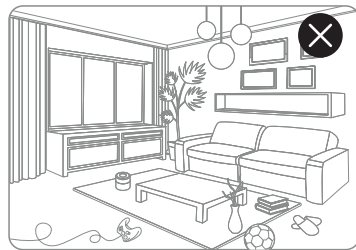

Product use

Preparation to start

Remove protection materials

- 1.Remove the host guard strip
- 2.Remove the protective film

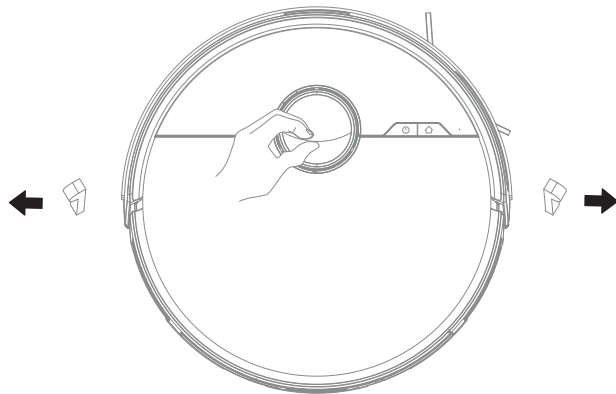

Installation on side brush

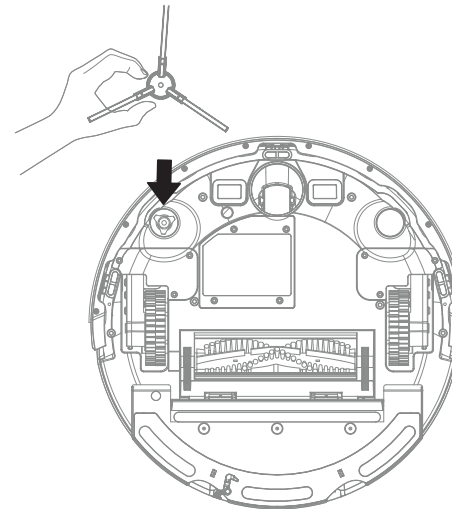

Product use

Robotic vacuum cleaner charging

Dust collector should be placed against the wall, placed on the flat ground, and do not place any items within 0.5m around and 1.5m ahead.

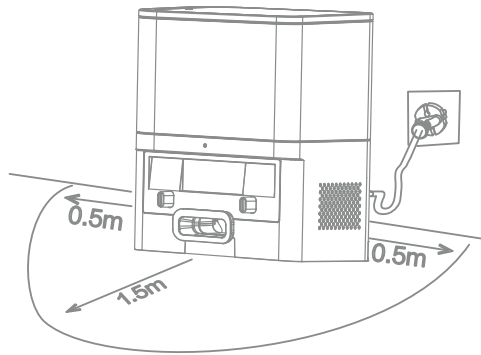

Charge

Long press  button to switch on, place the robotic vacuum cleaner on the dust collector to began charging.

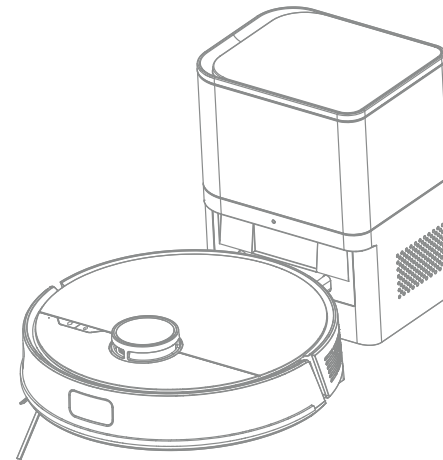

! Pay attention to:

- The charging station should not be used under direct sunlight or highly reflective environment nearby mirrors.
- In order to ensure that the robotic vacuum cleaner can be recharged smoothly after cleaning, the dust collector should not be moved once the robotic vacuum cleaner starts cleaning.

Product use

APP distribution network

1. Before connecting to Wifi network, you need to download the smart life APP, and then connect to Wifi network after registration and login. Make sure Wi-Fi is 2.4GHz before connecting.

2. Preparation: Click the APP "+" key to add the device.



Product use



3. Support the hot-spot connection mode:

- Choose robotic vacuum cleaner (Wi-Fi) in small home appliances.
- Please make sure that the Wi-Fi used is 2.4GHz, and enter the correct Wi-Fi password.
- Long press the device recharge button for 3s till the indicator light is flashing. When the indicator light is flashing in the APP, click Next key and select the hotspot connection in the pop-up options.
- Go to the mobile phone Wi-Fi list to find the password-free hotspot at the beginning of SmartLife-XXXX, click the connection, and return to the Smart life APP after success. The APP will automatically jump to the connection machine interface, and wait for the prompt connection to complete the connection to operate the machine.



Product use

Turn on / off

- Long press  key to start, the power indicator is on, the robot enters the standby state.
 - Long press  key to shutdown, the indicator lights all off, shutdown success.
- * The robotic vacuum cleaner cannot be shut down while charging.

Start cleaning

- Short press the key on the robotic vacuum cleaner to start the cleaning. After the start, the machine will dynamically plan the cleaning route according to the scanned map. In the selected cleaning area, the machine will start along the wall and then cleaning in zig-zag, orderly and efficient coverage.

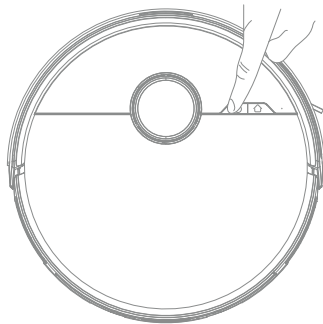

! Pay attention to:

- If the power is too low, it will not start cleaning. Please charge before you start cleaning.
- Please tidy up all kinds of wires on the ground before cleaning to avoid electrical power failure or wire damage caused by the machine when cleaning.

Pause / Continue

When the machine is in operation, press any key to pause. Press the  key to continue the cleaning.

Sleep / wake up

After more than 10 minutes without operation, the machine will automatically enter the dormant state. In the dormant state, the power indicator light is off, and press any key to wake up the machine.

Charge

- After the cleaning, the machine will automatically return to the dust collector to charge.
- In standby / pause state, press  to start the recharge.

Product use

Mopping the floor

1. Water tank filling

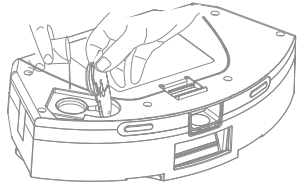

2. Install the mop board

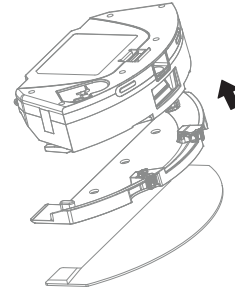

3. Install the water tank assembly back to the robotic vacuum cleaner

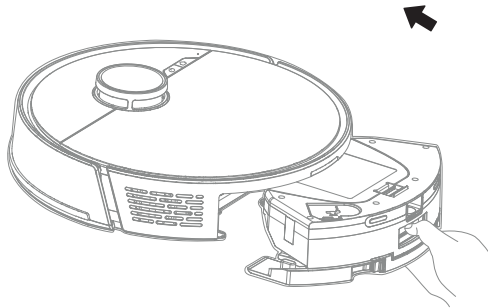

! Pay attention to:

- Do not use the mopping function on the carpet, do not start on the carpet
- when installing the mop.
- After mopping the floor, please empty the water tank, remove and clean the cloth, Keep the surface of water tank dry before use.

Parts maintenance

Frequency of maintenance

To achieve the best cleaning effect, clean and maintain the machine regularly according to the table below.

Please decide the frequency of cleaning and maintenance according to the actual use habits.

Part / component	Cleaning frequency	Change frequency
High-Efficiency Filter (HEPA)	Once a week	Every three to six months
Rolling brush	Once a week	Every six to twelve months
Side brush	Once a month	Every three to six months
Contact plates of charging station	Once a month	/
Universal wheel	Once a month	/
Each sensor	Once a month	/
Dust collector	/	Replace a new dust bag when prompt of dust bag full

Regular maintenance

Clean up the 2-in-one dust box water tank

1. Press the dust box button to remove the 2-in-1 water tank

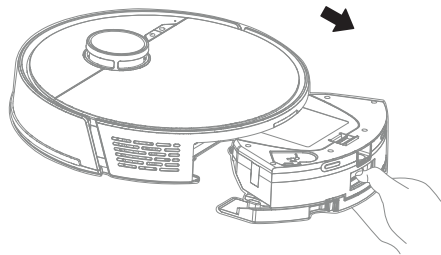

2. Empty the water tank

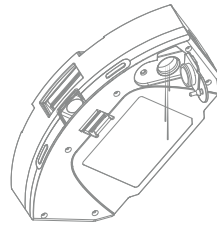

3. Open the dust box to dump the garbage

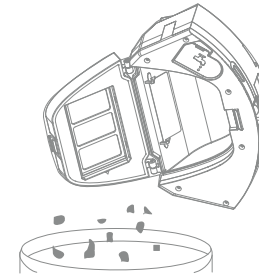

4. Take out the high efficient filter HEPA and the primary filter, tap the high efficient filter HEPA to remove dust

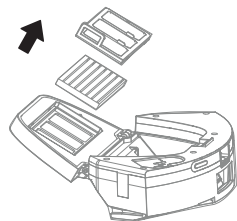

5. Wash the dust box, primary filter and filter sponge with water

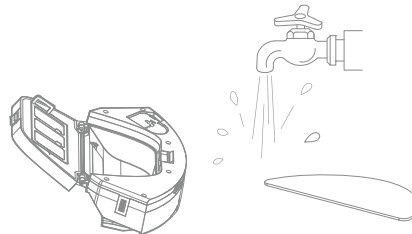

6. Dry the washed components

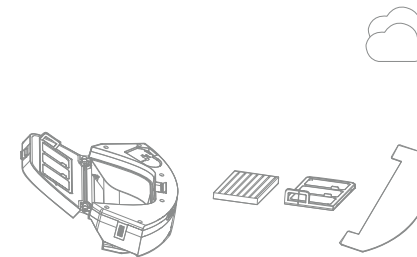

! Before installing the filters, make sure that the high efficient filter HEPA and the primary filter are dry.

Regular maintenance

Clean up the rolling brush

1. Open the roll-brush cover assembly

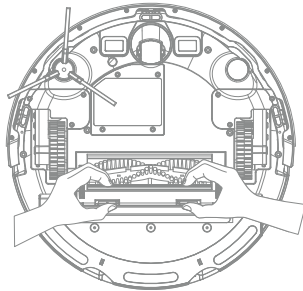

2. Remove the rolling brush

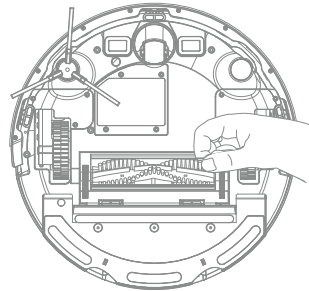

3. Clean up the roll brush with the tool

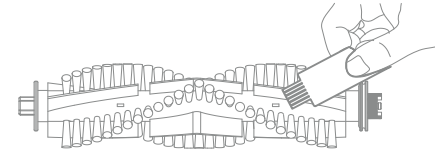

Clean up the side brush

1. Take off the side brushes

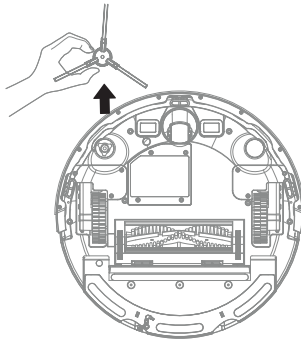

2. Clean up the side brushes with the tool

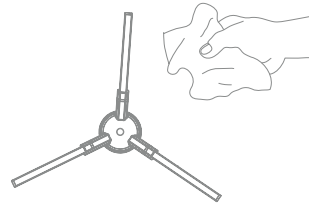

Regular maintenance

Clean up the sensor

! Use a soft dry cloth to wipe the various sensors in the machine

Contact plates of charging station

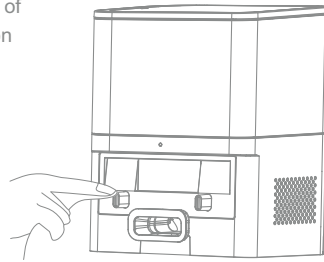

Ultrasonic sensor (optional)

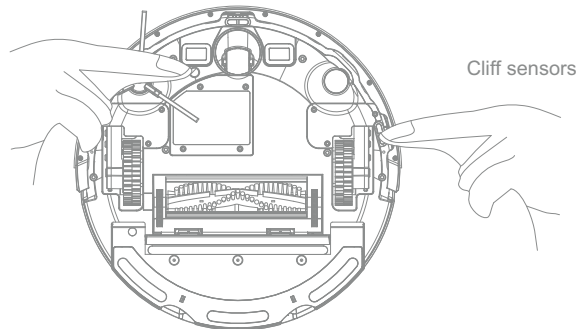

Cliff sensors

Dust collector maintenance

1. Clean up the charging plates
2. Remove the dust bag vertically and replace a new one.

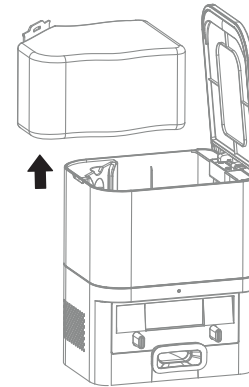

Common questions

Question	Possible causes and solutions
Can't boot	If the battery is low, please place the machine on dust collector for fully charge before use. If the battery temperature is too low or too high, please use it at 0-40°C.
Unable to charge	If the base is not powered on, please check the indication light is on; if not, please check the power cord for both ends have been properly inserted; Poor contact, please clean the charging plates of the charging station and the machine.
Slow charging	In high temperature or low temperature environment, the machine automatically reduce the charging speed in order to extend the battery life. The charging contact area may be dirty, please clean the area with a dry cloth.
Can't recharge	There are too many obstacles near the charging station, please put the charging station in open area; The machine is too far away from the charging station, please put the machine near the charging station and try again.
Abnormal behaviour	Please confirm whether the machine sensor is abnormal. If there is no abnormality, please turn the machine off and turn it on again.
Abnormal sounds when cleaning	The rolling brush, side brush or the main wheel may be entangled with obstacles, please stop and clean it. The universal wheel may be winding, it is recommended to take out the universal wheel for clean up.
Cleaning ability decrease or ash dropping	The dust box is full or the filter has been blocked, please clean the dust box and filter; The rolling brush is wrapped by obstacles, please clean up the rolling brush.
Unable to connect WiFi	If Wi-Fi function is not activated, please reset Wi-Fi and try again; The Wi-Fi signal is not good, please ensure that the machine is in a good Wi-Fi signal coverage area; If Wi-Fi connection is abnormal, reset Wi-Fi and download the latest mobile phone version. Try to connect again; Wi-Fi suddenly lost the connection, suspected that the home router is malfunction, you can contact the customer service for help; the machine does not support 5G network. Please switch it to 2.4G Wi-Fi
The machine is trapped at work	The machine may be entangled or stuck by the scattered wires and drooping curtains on the ground. It is recommended to tidy up the room before cleaning; The machine may be stuck by similar height of furniture, can either raise the high of furniture by adding some pad or block the furniture area for cleaning.

Product parameter

Robot vacuum cleaner	
Battery cell	14.4V/2600mAh Lithium-ion battery
Power input	19V/0.6A
Charging time	About 4.5h

Dust collector	
Power input	100-130V~ or 220-240V~
Power output	19V/0.7A

! Due to the continuous improvement of the product, the contents described in this specification are subject to change, and we reserve the right of continuous update.

Security Information

Component Type	Hazardous Substance					
	Lead (Pb) and its compounds	Mercury (Hg) and its compounds	Cadmium (Cd) and its compounds	Hexavalent chromium (Cr(VI)) and its compounds	Polybrominated biphenyls (PBB)	Poly Brominated Diphenyl Ethers(PBDE)
Plastic parts	O	O	O	O	O	O
Metal parts	X	O	X	O	O	O
Circuit module of the Robot	X	O	X	O	O	O
Electronic component	O	O	O	O	O	O
Battery	O	O	O	O	O	O
Power cord (Metal part)	X	O	X	O	O	O

O: It means that the content of the hazardous substance in all homogeneous materials of the part is below the limit requirement specified in the currently valid edition of EU ROHS.

X: It means that the content of the hazardous substance in at least one of the homogeneous materials of the component exceeds the limit requirement specified in the currently valid edition of EU ROHS. The content of the hazardous substance in the component is in the RoHS exemption list, and meet the environmental protection requirements of the 2011/65/EU and (EU)2015/863 ROHS Directive.



Standard compliance:

IEC/EN 60335-1
EN 300 328

IEC/EN 60335-2
EN 301 489-1

EN 55014-1
EN 301 489-17

EN 55014-2
FCC Part 15B



Product name: Robot Vacuum Cleaner

Product model: M30

Manufacturer: Shenzhen Free Dynamics Development Co., Ltd.

Address: Room 1201, South Block, Yuanxing science and technology building, Nanshan District, Shenzhen, China

Web.: www.freedynamics.com

Frequency Range: 2412MHz-2472MHz for WIFI;

Max. Power: 31.30W

SIMPLIFIED EU DECLARATION OF CONFORMITY

The simplified EU declaration of conformity referred to in Article 10(9) shall be provided as follows:

Shenzhen Free Dynamics Development Co., Ltd. declares that radio equipment type Conversion module(WBR3/RE741) is in compliance with Directive 2014/53/EU, and this product is allowed to be used in all EU member states.

The full text of the EU declaration of conformity is available at following

This product can be used across EU member states.

**BATTERY Warning: CAUTION:RISK OF EXPLOSION IF BATTERY IS REPLACED BY AN INCORRECT TYPE
DISPOSE OF USED BATTERIES ACCORDING TO THE INSTRUCTIONS**

FCC STATEMENT :

This device complies with Part 15 of the FCC Rules. Operation is subject to the following two conditions:

This device may not cause harmful interference, and

This device must accept any interference received, including interference that may cause undesired operation.

Warning: Changes or modifications not expressly approved by the party responsible for compliance could void the user's authority to operate the equipment.

NOTE: This equipment has been tested and found to comply with the limits for a Class B digital device, pursuant to Part 15 of the FCC Rules. These limits are designed to provide reasonable protection against harmful interference in a residential installation. This equipment generates uses and can radiate radio frequency energy and, if not installed and used in accordance with the instructions, may cause harmful interference to radio communications. However, there is no guarantee that interference will not occur in a particular installation. If this equipment does cause harmful interference to radio or television reception, which can be determined by turning the equipment off and on, the user is encouraged to try to correct the interference by one or more of the following measures:

Reorient or relocate the receiving antenna.

Increase the separation between the equipment and receiver.

Connect the equipment into an outlet on a circuit different from that to which the receiver is connected.

Consult the dealer or an experienced radio/TV technician for help.

FCC Radiation Exposure Statement:

This equipment complies with FCC radiation exposure limits set forth for an uncontrolled environment. This equipment should be installed and operated with minimum distance 20cm between the radiator & your body.

