

# XIAOMI Smart Kettle 2 Pro User Manual



Read this user manual carefully before use, and retain it for future reference.

## Precautions

---

- This appliance is intended to be used in household and similar applications such as:
  - staff kitchen areas in shops, offices and other working environments;
  - farm houses;
  - by clients in hotels, motels and other residential type environments;
  - bed and breakfast type environments.
- The appliance must not be immersed.
- The appliance is only to be used with the base provided.
- Do not let people who lack the physical, sensory, or intellectual ability or lack the experience or common sense to use this product without supervision or guidance.
- Never let children play with the kettle.
- Keep it away from children.
- When the kettle is empty, not in use, or when you are adding water in it, moving or cleaning it, or even when there is a problem with it, the kettle must be unplugged.
- Do not use this kettle on an inclined or unstable surface, and keep it away from heat sources so as to avoid damage to its plastic parts. Do not place the kettle adjacent to or on top of any electrical appliance.
- The kettle must only be used with a grounded power outlet with a rated current of 10 A or above, and a rated voltage of 220–240 V~. Do not plug the kettle into a power outlet together with other electrical appliances.
- If the power cord is damaged or broken, it must be replaced by the manufacturer or after-sales service department to avoid safety hazards.
- Do not open the kettle's lid, pour water out, or add water while the kettle is operating.
- If the kettle is overfilled, then boiling water could splash out.
- This kettle can only be used for boiling water. Do not use it to heat other things such as seaweed, eggs, soy milk, tea leaves, milk and noodles. Otherwise, the kettle may fail to function properly. Do not add water above the maximum water level mark. Otherwise, hot water will overflow or spray out, causing the kettle to leak. When boiling water, the water in the kettle must be above the minimum water level mark so as to prevent boil-dry.
- Please remove the kettle from the base when adding water, and wipe away any excess water from the bottom of the kettle before placing it back onto its base.
- Do not place the kettle near heat sources such as cookers and stoves so as to avoid the risk of fire.
- To avoid the risk of fire, do not use low-quality power strip with this product.
- Do not immerse the kettle in water. Do not tilt, shake, move, or tip the kettle when using it.
- This appliance can be used by children aged from 8 years and above if they have been given supervision or instruction concerning use of the appliance in a safe way and if they understand the hazards involved. Cleaning and user maintenance shall not be made by children unless they are older than 8 and supervised. Keep the appliance and its cord out of reach of children aged less than 8 years.
- Warning: avoid spillage on the connector.
- Heating element surface is subject to residual heat after use.

•Appliances can be used by persons with reduced physical, sensory or mental capabilities or lack of experience and knowledge if they have been given supervision or instruction concerning use of the appliance in a safe way and understand the hazards involved.

Note: When using the kettle for the first time, please boil water and empty the kettle for 3 times before drinking.

Warning: Don't move the kettle's lid while the water is boiling.

## Product Overview

---

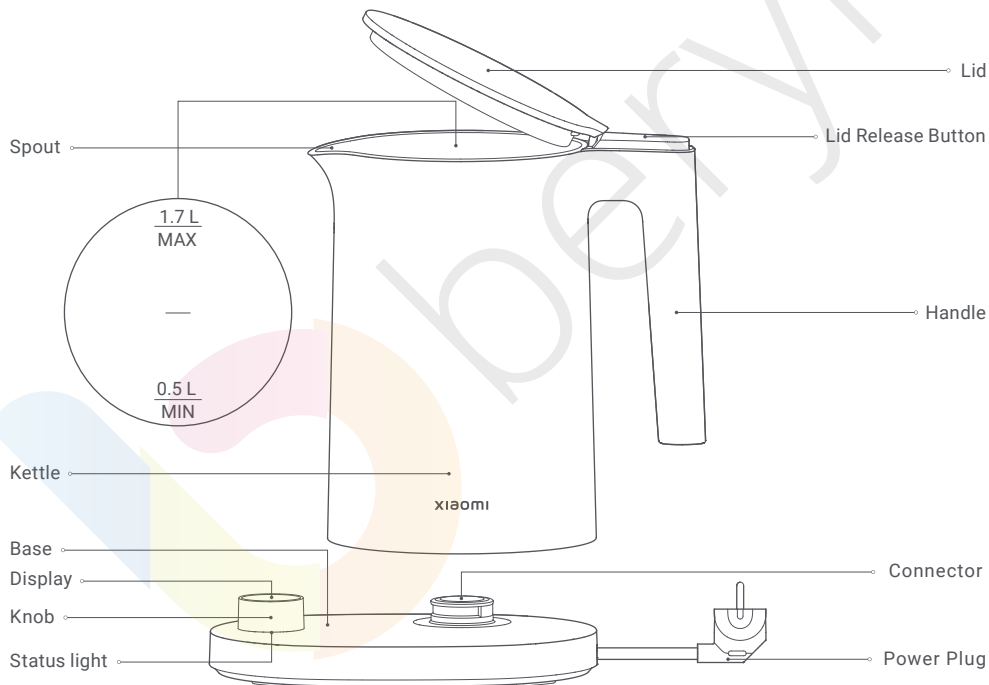

Note: Illustrations of product, accessories, and user interface in the user manual are for reference purposes only. Actual product and functions may vary due to product enhancements.

# Control Area

---

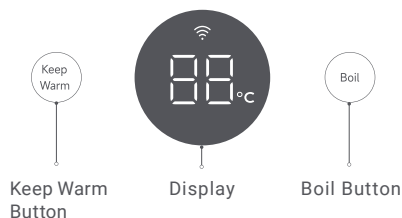

## How to Use

---

Once connected to the power, it is ready to use.

### 1. Select a function

In standby mode, turn the knob to select a temperature and the kettle will automatically enter the heating or keeping warm state once the keep warm or boil button is pressed. The display will go off automatically if there is no operation within 2 minutes, and it will light up when the boil or keep warm button is tapped, or the kettle is lifted (this operation will only light up the display and will not activate functions). Other operations can be performed after the display is turned on.

Note: The knob can be adjusted by 1 °C at 40 °C to 90 °C by default. The temperature may also be adjusted by level (six levels available) in the Mi Home/Xiaomi Home app, including four levels of 45 °C, 60 °C, 70 °C and 85 °C, and two custom temperature levels.

### 2. Automatically keep warm after boiling

Turn the knob to the keep warm temperature, and then press the boil button to start heating. The real-time water temperature will be shown on the display. Once boiled, the kettle will cool down to the keep-warm temperature and automatically enter the keep-warm state.

Notes:

1. The indicator on the display turns red during heating, and it will change to blue after the set temperature is reached.
2. The default keep warm duration for all temperature levels is 24 hours, which can also be customized from 1 to 24 hours in the Mi Home/Xiaomi Home app.
3. The highest temperature shown is 99 °C after boiling.

### 3. Heat directly to the keep warm temperature

Turn the knob to the set temperature, and then press the keep warm button to start heating. The real-time water temperature will be displayed on the display. Once done, the kettle will automatically enter the keep-warm state.

Note: In standby mode, when water temperature in the kettle is within the range of 40 °C to 90 °C, the kettle can enter the keep-warm state directly with current temperature once the keep warm button is pressed.

#### 4. Boil

Press the boil button to start heating. The real-time water temperature will be shown on the display. Once heating is completed, the water will cool down naturally.

Note: Both the mode light and status light turn off when the water temperature cools down after boiling, and the display will turn off when the water temperature is lower than 45 °C.

#### 5. Cancel heating

During heating, press the keep warm or boil button again to cancel heating.

#### 6. Remember keep warm temperature after lifting the kettle

During keeping warm, the display shows “--” after the kettle is lifted. In case the kettle is placed back within three minutes, it will still be in the keep warm mode. The kettle will exit the keep warm mode and return to the standby mode if it is placed back after three minutes.

Note: This function is enabled by default and can be disabled in the app.

#### 7. DND mode

DND mode can be enabled in the Mi Home/Xiaomi Home app. Once enabled, the status light will be turned off and the notification sound will be muted.

#### 8. Restore factory settings

In standby mode, press and hold the boil button for 7 seconds to restore the factory settings.

## Connect with Mi Home/Xiaomi Home App

---

This product works with Mi Home/Xiaomi Home app\*. Control your device with Mi Home/Xiaomi Home app.

Scan the QR code to download and install the app. You will be directed to the connection setup page if the app is installed already. Or search "Mi Home/Xiaomi Home" in the app Store to download and install it.

Open Mi Home/Xiaomi Home app, tap "+" on the upper right, and then follow prompts to add your device.

\* The app is referred to as Xiaomi Home app in Europe (except for Russia). The name of the app displayed on your device should be taken as the default.

Note: The version of the app might have been updated, please follow the instructions based on the current app version.



18CE2417

## Wi-Fi Connection

In standby mode, press and hold the keep warm and boil buttons for 7 seconds and the buzzer will beep once to indicate the start of Wi-Fi resetting. At this time, the Wi-Fi indicator is blinking and you need to connect the network through the Xiaomi Home app. Once connected, the Wi-Fi indicator will remain on.

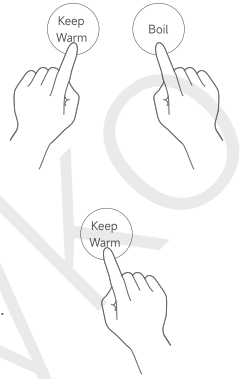

## Enable/Disable Wi-Fi

The Wi-Fi is disabled by default when the kettle is turned on for the first time.

In standby mode, press and hold the keep warm button for 7 seconds to enable/disable Wi-Fi.

## Wi-Fi Status

Waiting for connection...: Wi-Fi indicator blinks slowly.

Connecting...: Wi-Fi indicator is on.

Connected successfully: Wi-Fi indicator is on.

# Cleaning & Maintenance

---

1. Add 0.5 L of food-grade white vinegar and leave to soak for at least 1 hour.
2. After pouring out the white vinegar, wipe out any remaining sediment with a damp cloth.
3. Add water (above minimum mark and below the maximum mark) and pour out after it boils, and then use clean water to rinse the kettle for 4-5 times.
4. Use a dry cloth to clean the outside of the kettle. Keep the kettle in a dry, well-ventilated area, and protect it from dust, moisture, and insects.

### Precautions:

1. Make sure the kettle is unplugged and let it cool down before cleaning.
2. Regularly remove limescale and sediment inside the kettle to extend its service life.
3. If there is serious limescale buildup, please repeat the steps above. Do not use steel wool or any chemical or abrasive cleaning agents.
4. Do not immerse the kettle or the base in water, and keep its exterior dry.

# Troubleshooting

Issues	Possible Causes	Solutions
Display does not light up.	Power outlet is damaged or doesn't make proper contact.	Replace the electrical outlet.
	Power plug is not properly plugged in.	Properly plug in the power plug.
	Power plug is melted and deformed.	Contact the after-sales service team.
	Provided base is not used.	Use the provided base.
Display shows an error code.	Error code E1: Faulty temperature sensor	Contact the after-sales service team.
	Error code E2: Heating error	Contact the after-sales service team.
Kettle does not heat.	Circuit board is damaged.	Contact the after-sales service.
	Heating element is damaged.	Contact the after-sales service.
	Thermostat tripped due to boiling dry.	Wait until the temperature drops before use.
Power does not turn off after water boils, or kettle heats but water does not boil.	NTC temperature sensor is damaged.	Contact the after-sales service.
	The circuit has an error.	Contact the after-sales service.
App connection error.	The phone's Wi-Fi is not enabled.	Enable the phone's Wi-Fi.
	Control board is damaged.	Contact the after-sales service team.

# Specifications

Name: Electric Kettle	Model: MJJYSH01-A
Rated Voltage: 220-240 V~	Rated Power: 1800 W
Rated Frequency: 50/60 Hz	Capacity: 1.7 L
Wireless Connectivity: Wi-Fi IEEE 802.11b/g/n 2.4 GHz	Net Weight: 1.20 kg
Wireless Connectivity: Bluetooth Low Energy	Frequency Range: 2400-2483.5 MHz
Maximum Output Power: ≤20 dBm	Item Dimensions: 273 × 155 × 242 mm
Power consumption of networked standby: <2.0 W	

# WARRANTY NOTICE

---

THIS WARRANTY GIVES YOU SPECIFIC RIGHTS, AND YOU MAY HAVE OTHER RIGHTS CONVEYED BY LAWS OF YOUR COUNTRY, PROVINCE OR STATE. INDEED, IN SOME COUNTRIES, PROVINCES OR STATES, CONSUMER LAW MAY IMPOSE A MINIMUM WARRANTY PERIOD. OTHER THAN AS PERMITTED BY LAW, XIAOMI DOES NOT EXCLUDE, LIMIT OR SUSPEND OTHER RIGHTS YOU MAY HAVE. FOR A FULL UNDERSTANDING OF YOUR RIGHTS WE INVITE YOU TO CONSULT THE LAWS OF YOUR COUNTRY, PROVINCE OR STATE.

## 1. LIMITED PRODUCT WARRANTY

XIAOMI warrants that the Products are free from defects in materials and workmanship under normal use and use in accordance with the respective Product user manual, during the Warranty Period.

The duration and conditions related to the legal warranties are provided by respective local laws. For more information about the consumer warranty benefits, please refer to Xiaomi's official website <https://www.mi.com/global/support/warranty>.

Xiaomi warrants to the original purchaser that its Xiaomi Product will be free from defects in materials and workmanship under normal use in the period mentioned above.

Xiaomi does not guarantee that the operation of the Product will be uninterrupted or error free.

Xiaomi is not liable for damages arising from non-compliance with the instructions related to the use of the Product.

## 2. REMEDIES

If a hardware defect is found and a valid claim is received by Xiaomi within the Warranty Period, Xiaomi will either (1) repair the product at no charge, (2) replace the product, or (3) refund the Product, excluding potential shipping costs.

## 3. HOW TO OBTAIN WARRANTY SERVICE

To obtain warranty service, you must deliver the Product, in its original packaging or similar packaging providing an equal degree of Product protection, to the address specified by Xiaomi. Except to the extent prohibited by applicable law, Xiaomi may require you to present proofs or proof of purchase and / or comply with registration requirements before receiving warranty service.

## 4. EXCLUSIONS AND LIMITATIONS

Unless otherwise stipulated by Xiaomi, this Limited Warranty applies only to the Product manufactured by or for Xiaomi and identifiable by the trademarks, trade name or "Xiaomi" or "Mi" logo.

The Limited Warranty does not apply to any (a) Damage due to acts of nature or God, for example, lightning strikes, tornadoes, flood, fire, earthquake or other external causes; (b) Negligence; (c) Commercial use; (d) Alterations or modifications to any part of the Product; (e) Damage caused by use with non-Xiaomi products; (f) Damage caused by accident, abuse or misuse; (g) Damage caused by operating the Product outside the permitted or intended uses described by Xiaomi or with improper voltage or power supply; or (h) Damage caused by service (including upgrades and expansions) performed by anyone who is not a representative of Xiaomi.

It is your responsibility to backup any data, software, or other materials you may have stored or preserved on the product. It is likely that the data, software or other materials in the equipment will be lost or reformatted during the service process, Xiaomi is not responsible for such damage or loss.

No Xiaomi reseller, agent, or employee is authorized to make any modification, extension, or addition to this Limited Warranty. If any term is held to be illegal or unenforceable, the legality or enforceability of the remaining terms shall not be affected or impaired.

Except as prohibited by laws or otherwise promised by Xiaomi, the after-sales services shall be limited to the country or region of the original purchase.

Products which were not duly imported and/or were not duly manufactured by Xiaomi and/or were not duly acquired from Xiaomi or a Xiaomi's official seller are not covered by the present warranties. As per applicable law you may benefit from warranties from the non-official retailer who sold the product. Therefore, Xiaomi invites you to contact the retailer from whom you purchased the product.

The present warranties do not apply in Hong Kong and Taiwan.

#### 5. IMPLIED WARRANTIES

Except to the extent prohibited by applicable law, all implied warranties (including warranties of merchantability and fitness for a particular purpose) will have a limited duration up to a maximum duration of this limited warranty. Some jurisdictions do not allow limitations on the duration of an implied warranty, so the above limitation will not be applied in these cases.

#### 6. DAMAGE LIMITATION

Except to the extent prohibited by applicable law, Xiaomi shall not be liable for any damages caused by accidents, indirect, special or consequential damages, including but not limited to loss of profits, revenue or data, damages resulting from any breach of express or implied warranty or condition, or under any other legal theory, even if Xiaomi has been informed of the possibility of such damages. Some jurisdictions do not allow the exclusion or limitation of special, indirect, or consequential damages, so the above limitation or exclusion may not apply to you.

#### 7. XIAOMI CONTACTS

For customers, please visit the website: <https://www.mi.com/global/support/warranty>.

The contact person for the after-sale service may be any person in Xiaomi's authorized service network, Xiaomi's authorized distributors or the final vendor who sold the products to you. If in doubt please contact the relevant person as Xiaomi may identify.



## EU Declaration of Conformity

We, Foshan Viomi Electrical Technology Co., Ltd., hereby, declare that this equipment is in compliance with the applicable Directives and European Norms, and amendments. The full text of the EU declaration of conformity is available at the following internet address: <http://www.mi.com/global/service/support/declaration.html>



## WEEE Information

All products bearing this symbol are waste electrical and electronic equipment (WEEE as in directive 2012/19/EU) which should not be mixed with unsorted household waste. Instead, you should protect human health and the environment by handing over your waste equipment to a designated collection point for the recycling of waste electrical and electronic equipment, appointed by the government or local authorities. Correct disposal and recycling will help prevent potential negative consequences to the environment and human health. Please contact the installer or local authorities for more information about the location as well as terms and conditions of such collection points.

Manufactured for: Xiaomi Communications Co., Ltd.

Manufactured by: Foshan Viomi Electrical Technology Co., Ltd.

(a Mi Ecosystem company)

Address: 13th Floor, No. 7, Industrial Road, Licun Village, Lunjiao Town, Shunde District, Foshan City, Guangdong Province, P.R. China

For further information, please go to [www.mi.com](http://www.mi.com)

For details of the importer, please refer to the box.

Production Date: See box

Made in China

User Manual Version: V1.0

EU REP.

Xiaomi Technology Netherlands B.V.

Prinses Beatrixlaan 582, 2595BM, The Hague, The Netherlands

[contact@support.mi.com](mailto:contact@support.mi.com)

Importer:

Beryko s.r.o.

Pod Vinicemi 931/2, 301 00 Plzeň

[www.beryko.cz](http://www.beryko.cz)

beryko

